



# CITY OF OKANOGAN Water System Plan

G&O# 15012  
SEPTEMBER 2016



**Gray & Osborne, Inc.**



# Water System Plan Submittal Form

This form must be completed and submitted along with the Water System Plan (WSP). It will expedite review and approval of your WSP. All water systems should contact their regional planner before developing any planning document for submittal.

City of Okanogan	63200 M	City of Okanogan	
1. Water System Name	PWS ID# or Owner ID#	Water Systems Owner's Name	
Mr. Shawn Davisson	(509) 422-3600	Public Works Superintendent	
Contact Name for Utility	Phone Number	Title	
120 Third Avenue North	Okanogan	Washington	98840
Contact Address	City	State	Zip
Mr. David Ellis, P.E.	(509) 453-4833	Project Engineer	
2. Project Engineer	Phone Number	Title	
107 South 3 <sup>rd</sup> Street	Yakima	Washington	98901
Project Engineer Address	City	State	Zip
3. Billing Contact Name (required if not the same as #1)		Billing Fax Number	
Billing Address	City	State	Zip

- How many services are presently connected to your system? 981
- Is your system expanding (seeking to extend service area or increase number of approved connections)?  Yes  No
- If the number of services is expected to increase, how many *new* connections are proposed in the next six years? 41
- If your system is private-for-profit, is it regulated by the State Utilities and Transportation Commission? Not Applicable  Yes  No
- Is the system located in a Critical Water Supply Service Area (i.e., have a Coordinated Water System Plan)?  Yes  No
- Is your system a customer of a wholesale water system?  Yes  No
- Will your system be pursuing additional water rights from the Department of Ecology in the next 20 years?  Yes  No
- Is your system proposing a new intertie?  Yes  No
- Do you have projects currently under review by us?  Yes  No
- Are you requesting distribution main project report and construction document submittal exception and if so, does the WSP contain standard construction specifications for distribution mains?  Yes  No
- The water system is responsible for sending a copy of the WSP to adjacent utilities for review or a letter notifying them that a copy of the WSP is available for their review and where the review copy is located. Has this been completed?  Yes  No
- The purveyor is responsible for sending a copy of the WSP to all local governments within the service area (county and city planning departments, etc.). Has this been completed?  Yes  No
- Are you proposing a change in the place of use of your water right?  Yes  No

If answer to questions 7,8, 11, 14 and/or 15 is "yes," list who you sent the WSP to: Sent notice to Progressive Flats Water Association, City of Omak, Okanogan County Fair, and Our Lady of Valley Catholic Church. Sent applicable plan chapters to the Okanogan County and Confederated Tribes of the Colville Reservation planning departments.

Is this plan:  an Initial Submittal  a Revised Submittal

Please enclose the following number of copies of the WSP:

3 copies for Northwest and Southwest Regional Offices OR 2 copies for Eastern Regional Office (We will send one copy to Ecology)  
1 additional copy if you answered "yes" to question 7. 2 Total copies attached

Please return completed form to the Office of Drinking Water regional office checked below.

Northwest Drinking Water Operations  
Department of Health  
20425 72<sup>nd</sup> Avenue South, Suite 310  
Kent, WA 98032-2358  
253-395-6750

Southwest Drinking Water Operations  
Department of Health  
PO Box 47823  
Olympia, WA 98504-7823  
360-236-3030

Eastern Drinking Water Operations  
Department of Health  
16201 East Indiana Avenue Suite 1500  
Spokane Valley, WA 99216  
509-329-2100

For people with disabilities, this document is available on request in other formats. To submit a request, please call 1-800-525-0127 (TDD/TTY call 711).





COPY

JUN 21 2016  
FOLIO 7  
OKANOGAN, WA 98840

STATE OF WASHINGTON  
DEPARTMENT OF HEALTH  
EASTERN DRINKING WATER REGIONAL OPERATIONS  
16201 E Indiana Avenue, Suite 1500, Spokane Valley, Washington 99216-2830  
TDD Relay 1-800-833-6388

June 17, 2016

Shawn Davisson  
City of Okanogan  
P.O. Box 752  
Okanogan, WA 98840

Subject: City of Okanogan; PWS ID #63200; Okanogan County  
Water System Plan; Submittal #16-0311; DOH Comments

Dear Mr. Davisson:

Thank you for providing the draft Water System Plan (WSP) for the City of Okanogan received in this office on March 25, 2016. The following comments will need to be addressed before the Department of Health (DOH) can approve the document:

### Chapter 1

1. Indicate on Figure 1-1 where the intertie and booster pump station are located that serves Progressive Flats Water Association (PFWA).
2. The WSP is required to describe and map four service areas. They are the Existing Service Area, Retail Service Area, Future Service Area, and Service Area (Water Rights Place of Use). Include descriptions of all four in the narrative and depict each one on a map. Definitions for each service area can be found in WAC 246-290-010. Make sure when mapping the Service Area that it includes everywhere that the City wholesales water such as PFWA.
3. Please include in an appendix Resolution No. 2006-19, and reference the appendix in the service area section.
4. Include a **Duty to Serve** statement for the retail service area that addresses the four thresholds for service as described in WAC 246-290-106(1).

### Chapter 2

5. Page 2-4. Show monthly and annual production totals for each source for 2014.
6. Add a column in Table 2-4 for water sold through the City's intertie with PFWA.
7. Systems with 1000 or more service connections must show the seasonal variation in water demand by customer class. Since the City does not read meters for residential services over the winter, the values can be averaged for that period. Only one year of data is required.

8. Is PFWA's water usage in Table 2-9 based upon readings from the master meter to PFWA or from the 2007 Preliminary Engineering Report? Actual meter reading should be used in the analysis.
9. Table 2-11. Provide some narrative about why the ERU value of 286 was not used in this table. The ERU value used appears to be 336 gpd. If this difference is accounting for DSL, please indicate the amount of DSL added and how that amount was determined.
10. Table 2-12. Explain the calculations used in the table. Specifically, identify DSL and customer demand reductions to show how each contributes to the overall reduction in ADD for each year.

#### Chapter 4

11. Page 4-2, Interties. The City is intertied with Progressive Flats Water Association. The intertie discussion on page 4-2 needs to be revised to include the (one-way) intertie with PFWA. Also, include an intertie agreement that indicates the annual volume of water the City has agreed to sell to PFWA.
12. Page 4-4, WUE Education. Describe the method the City will employ to notify customers about WUE education.
13. Table 4-4. The values used for year 2035 are inconsistent with those in Table 2-11 and 2-12. Please revise.
14. Page 4-5, Distribution System Leakage. The reported three-year average DSL of 12 percent is inconsistent with Table 2-6. Please revise.
15. Page 4-6, Water Loss Control Action Plan. The WLCAP needs to address the following five elements described in 246-290-820(4):
  - (a) The control methods necessary to achieve compliance with the distribution system leakage standard;
  - (b) An implementation schedule;
  - (c) A budget that demonstrates how the control methods will be funded;
  - (d) Any technical or economic concerns which may affect the system's ability to implement a program or comply with the standard including past efforts and investments to minimize leakage;
  - (e) If the average distribution system leakage calculated under subsection (2) of this section is greater than ten and less than twenty percent of total water produced and purchased, the water loss control action plan must assess data accuracy and data collection;
16. Page 4-6, Conservation Rate Structure. The City must evaluate either an inclining block rate structure, or a seasonal rate structure.
17. Page 4-6, Water Reclamation. If an executive summary is available from the evaluation performed in 2008, include it in an appendix and reference the appendix location in this section.



18. Page 4-6, Water Supply Characteristics. This section also needs to address the effect on the groundwater source (quantity and quality) as it continues to be used into the future.
19. Water Supply Reliability Analysis/Depth to Water. Show depth to water data for trends in the water levels for all the systems active wells. WAC 246-290-415(9) requires purveyors to monitor static water level in the wells on a seasonal (quarterly) basis. If the City is not currently measuring depth to water, describe in the plan how the city will begin taking these measurements including an implementation schedule and costs. Include the costs in the budget.
20. Chapter 4, WUE Goal Setting Documentation. Include signed meeting minutes from the February 16, 2016 Council meeting where the WUE goal was adopted. Also include the documentation of the meeting notice as required in WAC 246-290-830(4)(b).
21. The Department of Ecology has issued a comment letter regarding this submittal. A copy of the review letter dated April 27, 2016 from the Department of Ecology is enclosed. Please address the issues, if any, contained in the letter in the second draft submittal.

## **Chapter 7**

22. Construction Standards. Please note that the “weep hole” drilled at the bottom of riser pipe for an air release valve or blow-off assembly is a potential cross-connection and, if possible, should be avoided. Possible alternatives to the weep hole is to wrap the riser pipe with heat tape or install the air release vent or blow-off inside a vault. When the air release vent is installed in a vault, the vault must have daylight drain to prevent the vent opening from become submerged.

## **Other**

23. Appendix A. On April 1, 2016, the federal Revised Total Coliform Rule (RTCR) replaced the 1989 Total Coliform Rule (TCR). Please revise your coliform monitoring plan (CMP) in accordance with the new RTCR. Additional RTCR information and a new CMP template are available on our website at:  
<http://www.doh.wa.gov/CommunityandEnvironment/DrinkingWater/Contaminants/Coliform/RevisedTotalColiformRuleRTCR>. Several differences between the RTCR and TCR include:
  - a. RTCR requires all water systems to collect three (3) repeat samples for every total coliform-present sample.
  - b. RTCR does not allow any system to use a source sample as both a repeat sample and a groundwater sample.
  - c. RTCR requires water system to collect their normal number of routine samples the month after a total coliform-present routine sample. City of Okanogan is no longer required to collect five samples in the month following an unsatisfactory sample.
24. Appendix G. Please provide the “Fire Flow Requirement for Large Structures” letter in Appendix G that is referenced on page 3-10.

25. Appendix I, SEPA. Provide a signed determination along with a signed copy of the checklist.
26. Provide documentation of the informational meeting, and notification of the meeting, held for the systems customers presenting information on the WSP update. If this took place at a City Council meeting, make sure that the meeting minutes are signed.
27. Attach a copy of the notice sent to the adjacent water utilities, a list of the utilities that were notified, and any comments that the City received back. Include the utilities mentioned on page 3-4.
28. When DOH is ready to approve the document we will notify you. At that time the governing body will need to officially approve the Water System Plan and send DOH documentation of plan approval by the governing body, such as a copy of the signed meeting minutes or a copy of the signed resolution. When the documentation is received we will send a letter documenting DOH approval.

### **Recommendations**

The following recommendations do not affect whether the Water System Plan (WSP) can be approved. They are provided to help improve the content of the plan, eliminate minor inconsistencies, and provide an opportunity to clarify some non-typical content or circumstances.

- Page ES-2 says the City intends to decommission well #4. It is not clear if this is the current well #4, or a well that remained when well #4 was re-drilled in 2001. Please clarify.
- Page 2-11 incorrectly states the medium growth rate was used from the 2003 comp plan.
- The DSL for 2012 is different from what was reported to the Department on the annual WUE Report. Contact Larry Granish at (360) 236-3141 to correct your 2012 report.
- Page 3-4, Paragraph 2. Identify all of the other Group A and B water systems in the City's service area on a map. Specifically identify which of the systems (including PWS ID# if available) the City would like to consider for consolidation. DOH has a consolidation feasibility grant that can pay to study the costs and engineering needed to consolidate other Group A systems. Indicate in the plan if the City plans to apply for those grant funds. These systems also need to be notified that the City has a draft WSP update available for review.
- Table 3-12. Include consolidation feasibility studies and projects as appropriate.
- Chapter 5. Include the declaration of covenants restricting the use of the land in each well's sanitary control area. If the City has not developed these covenants, please include them under the Long-Term Contingency Planning section in Chapter 5.

### **END OF COMMENTS**

The department's review of your water system plan does not confer or guarantee any right to a specific quantity of water. Our review is based on your representation of available water quantity. If the Washington Department of Ecology, a local planning agency, or other authority responsible for determining water rights and water system adequacy determines that you have use of less water than you represent, the number of approved connections may be reduced commensurate with the actual amount of water and your legal right to use it.



Shawn Davisson  
June 17, 2016  
Page 5

We hope that you have found these comments to be clear, constructive, and helpful in the development of your final WSP. We ask that you submit **two copies** of the revised WSP **on or before September 17, 2016**. In order to expedite the review of your revised submittal, please complete the enclosed DOH Comment Response Form summarizing how each of the above comments was addressed in the revised WSP and where each response is located (i.e., page numbers, Appendices, etc.)

Regulations establishing a schedule for fees for review of planning, engineering, and construction documents have been adopted (WAC 246-290-990). Please note that we have included an invoice for **\$3,705.00** for the review of the Water System Plan. This fee covers our cost for review of the initial submittal, plus the review of one revised document. Please remit your complete payment in the form of a check or money order within thirty days of the date of this letter to: DOH, Revenue Section, P.O. Box 1099, Olympia, WA 98507-1099.

Thank you again for submitting your draft Water System Plan for our review. If you have any comments or questions concerning our review please contact either of us at (509) 329-2117 or (509) 329-2122, respectively.

Sincerely,



Mike Wilson, P.E.  
Regional Engineer  
Office of Drinking Water  
Division of Environmental Public Health



Benjamin A. Serr  
Regional Planner  
Office of Drinking Water  
Division of Environmental Public Health

Enclosures: Invoice  
Comment Response Form  
Department of Ecology correspondence

cc: David Glyn Ellis, P.E., Gray & Osborne, Inc. & Associates  
Okanogan County Public Health  
Okanogan County Building and Planning  
Ying Fu, Department of Ecology, Eastern Regional Office  
George Simon, DOH Regional Compliance Program Director  
Alyssa Gersdorf, DOH WFI Coordinator



## DOH COMMENT RESPONSE FORM

DOH Comment No.	DOH Comment	Water System Response	Page Number of Response
<b>Chapter 1 – Description of the Water System</b>			
1	Indicate on Figure 1-1 where the <u>intertie</u> and <u>booster pump station</u> are located that serves Progressive Flats Water Association (PFWA).	The PFWA intertie and the booster pump station serving the PFWA (Sunrise BPS) are indicated on the figure.	Fig. 1-1
2	The WSP is required to describe and map four service areas. They are the Existing Service Area, Retail Service Area, Future Service Area, and Service Area (Water Rights Place of Use). Include descriptions of all four in the narrative and depict each one on a map. Definitions for each service area can be found in WAC 246-290-010. Make sure when mapping the Service Area that it includes everywhere that the City wholesales water such as PFWA.	Discussion of service areas added to Chapter 1. Figure 1-3 updated to include service area boundaries.	Page 1-15, Figure 1-3
3	Please include in an appendix Resolution No. 2006-19, and reference the appendix in the service area section.	Resolution 2006-19 included in the appendix.	Page 1-16, Table 1-6, Appendix N
4	Include a <b>Duty to Serve</b> statement for the retail service area that addresses the four thresholds for service as described in WAC 246-290-106(1).	Retail service area duty to serve added to Chapter 1.	Page 1-16
<b>Chapter 2 – Planning Data</b>			
5	Page 2-4. Show monthly and annual production totals for each source for 2014.	Figure showing monthly production for each source and total production for 2014 added as Figure 2-3.	Figure 2-3
6	Add a column in Table 2-4 for water sold through the City's intertie with PFWA.	Column added to table for PFWA metered consumption totals. PFWA consumption was previously included in the City's residential water consumption total in this table.	Table 2-4
7	Systems with 1000 or more service connections must show the seasonal variation in water demand by customer class. Since the City does not read meters for residential services over the winter, the values can be averaged for that period. Only one year of data is required.	Seasonal variations in consumption by customer class graph added to Chapter 2.	Figure 2-4

DOH Comment No.	DOH Comment	Water System Response	Page Number of Response
Chapter 2 – Planning Data			
8	Is PFWA’s water usage in Table 2-9 based upon readings from the master meter to PFWA or from the 2007 preliminary Engineering Report? Actual meter reading should be used in the analysis.	PFWA water usage has been separated from the City’s consumption total in Table 2-4, eliminating the need for Table 2-9.	N/A
9	Table 2-11. Provide some narrative about why the ERU value of 286 was not used in this table. The ERU value used appears to be 336 gpd. If this difference is accounting for DSL, please indicate the amount of DSL added and how that amount was determined.	<p>The basis of projections used in this table is the projected growth rate (0.42%) and the 4-year average 2010-2014 ADD value of 547,000 gpd shown in Table 2-2. Starting with a higher ADD than that of 2014 (463,000 gpd), which was the lowest year in the last 8 years, is somewhat conservative. This accounts for the apparent discrepancy noted.</p> <p>Note that the previously calculated value of 286 gpd/ERU has been corrected to 270 gpd/ERU. The previously value included PFWA consumption without the PFWA connections. The current value includes only the City’s residential consumption and connections. This change has affected various tables throughout the Plan but has had minimal impact on the overall analysis.</p>	Page 2-13
10	Table 2-12. Explain the calculations used in the table. Specifically, identify <u>DSL</u> and <u>customer demand</u> reductions to show how each contributes to the overall reduction in ADD for each year.	Projected reductions in DSL (from 10.4% to 8%) and consumption (from 0% to 3%) are calculated in the reduced ADD shown in the table from 2015-2021. Reductions are spread evenly over the six years (0.4% reduction in DSL and 0.5% reduction in consumption each year from 2015-2021).	Table 2-11 and new Table 2-12

DOH Comment No.	DOH Comment	Water System Response	Page Number of Response
Chapter 4 – Water Resource Analysis and Water Use Efficiency			
11	Page 4-2, Interties. The City is intertied with Progressive Flats Water Association. The intertie discussion on page 4-2 needs to be revised to include the (one-way) intertie with PFWA. Also, include an intertie agreement that indicates the annual volume of water the City has agreed to sell to PFWA.	Discussion of the intertie is added to this chapter and a copy of the signed agreement included in the appendix.	Page 4-2 Appendix M
12	Page 4-4, WUE Education. Describe the method the City will employ to notify customers about WUE education.	Discussion regarding consumer WUE education included in this chapter.	Page 4-4
13	Table 4-4. The values used for year 2035 are inconsistent with those in Table 2-11 and 2-12. Please revise.	Table 4-4 has been revised accordingly.	Table 4-4
14	Page 4-5, Distribution System Leakage. The reported three-year average DSL of 12 percent is inconsistent with Table 2-6. Please revise.	The DSL was changed from the 2011 – 2013 average of 12.3% to the 2012 – 2014 average of 10.4%.	Page 4-5
15	Page 4-6, Water Loss Control Action Plan. The WLCAP needs to address the following five elements described in 246-290-820(4): (a) The control methods necessary to achieve compliance with the distribution system leakage standard; (b) An implementation schedule; (c) A budget that demonstrates how the control methods will be funded; (d) Any technical or economic concerns which may affect the system’s ability to implement a program or comply with the standard including past efforts and investments to minimize leakage; (e) If the average distribution system leakage calculated under subsection (2) of this section is greater than ten and less than twenty percent of total water produced and purchased, the water loss control action plan must assess data accuracy and data collection.	The WLCAP has been updated in the Plan.	Page 4-6
		Water System Response	Page

DOH Comment No.	DOH Comment		Number of Response
Chapter 4 – Water Resource Analysis and Water Use Efficiency			
16	Page 4-6, Conservation Rate Structure. The City must evaluate either an inclining block rate structure, or a seasonal rate structure.	Inclined block rate structure evaluation added to this chapter.	Page 4-7 and Table 4-5
17	Page 4-6, Water Reclamation. If an executive summary is available from the evaluation performed in 2008, include it in an appendix and reference the appendix location in this section.	Executive summary not available.	N/A
18	Page 4-6, Water Supply Characteristics. This section also needs to address the effect on the groundwater source (quantity and quality) as it continues to be used into the future.	Effects of groundwater withdrawal on groundwater quality and quantity discussion added to this chapter.	Page 4-8
19	Water Supply Reliability Analysis/Depth to Water. Show depth to water data for trends in the water levels for all the systems active wells. WAC 246-290-405(9) requires purveyors to monitor static water level in the wells on a seasonal (quarterly) basis. If the City is not currently measuring depth to water, describe in the plan how the city will begin taking these measurements including an implementation schedule and costs. Include the costs in the budget.	The City does not currently monitor groundwater levels in any of its wells. Improvements to facilitate groundwater depth measurements at the City's wells will be made in accordance with the City's well improvements projects as shown in Chapter 8.	Table 8-1
20	Chapter 4, WUE Goal Setting Documentation. Include signed meeting minutes from the February 16, 2016 Council meeting where the WUE goal was adopted. Also include the documentation of the meeting notice as required in WAC 246-290-830(4)(b).	The documentation is included at the end of this chapter.	Chapter 4
21	The Department of Ecology has issued a comment letter regarding this submittal. A copy of the review letter dated April 27, 2016 from the Department of Ecology is enclosed. Please address the issues, if any, contained in the letter in the second draft submittal.	There are no issues in the letter that need to be addressed.	N/A

DOH Comment No.	DOH Comment	Water System Response	Page Number of Response
Chapter 7 –			
22	<p>Construction Standards. Please note that the “weep hole” drilled at the bottom of riser pipe for an air release valve or blow-off assembly is a potential cross-connection and, if possible, should be avoided. Possible alternatives to the weep hole is to wrap the riser pipe with heat tape or install the air release vent or blow-off inside a vault. When the air release vent is installed in a vault, the vault must have daylight drain to prevent the vent opening from becoming submerged.</p>	<p>The City recognizes the cross connection potential that the weep hole design presents; however, the suggested alternatives are either not feasible (power source required) or cost prohibitive (power source or large vault). The City will endeavor to utilize the suggested alternatives in new installations where feasible and economically viable.</p>	N/A
Other			
23	<p>Appendix A. On April 1, 2016, the federal Revised Total Coliform Rule (RTCR) replaced the 1989 Total Coliform Rule (TCR). Please revise your coliform monitoring plan (CMP) in accordance with the new RTCR. Additional RTCR information and a new CMP template are available on our website at: <a href="http://www.doh.wa.gov/CommunityandEnvironment/DrinkingWater/Contaminants/Coliform/RevisedTotalColiformRuleRTCR">http://www.doh.wa.gov/CommunityandEnvironment/DrinkingWater/Contaminants/Coliform/RevisedTotalColiformRuleRTCR</a>. Several differences between the RTCR and TCR include:</p> <ol style="list-style-type: none"> <li>a. RTCR requires all water systems to collect three (3) repeat samples for every total coliform-present sample.</li> <li>b. RTCR does not allow any system to use a source sample as both a repeat sample and groundwater sample.</li> <li>c. RTCR requires water system to collect their normal number of routine samples the month after a total coliform-present routine sample. City of Okanogan is no longer required to collect five samples in the month following an unsatisfactory sample.</li> </ol>	<p>City to update Coliform Monitoring Plan and submit to Health.</p>	N/A



Other			
24	Appendix G. Please provide the “Fire Flow Requirement for Large Structures” letter in Appendix G that is referenced on page 3-10.	The documentation is included in the appendix.	Page 3-10, Appendix G
25	Appendix I, SEPA. Provide a signed determination along with a signed copy of the checklist.	The documentation is included in the appendix.	Appendix I
26	Provide documentation of the information meeting, and notification of the meeting, held for the systems customers presenting information on the WSP update. If this took place at a City Council meeting, make sure that the meeting minutes are signed.	Agenda and minutes for June 16, 2016 and minutes for July 12, 2016 City Council meetings to discuss and take comment on water system plan are included in the appendix.	Appendix O
27	Attach a copy of the notice sent to the adjacent water utilities, a list of the utilities that were notified, and any comments that the City received back. Included the utilities mentioned on page 3-4.	Notices to adjacent utility providers are provided in the appendix. The notices were sent to Group A water systems identified by Health in January 20, 2016 email from Michael Wilson. The Way S water system was considered a Group B system at that time.	Appendix P
28	When DOH is ready to approve the document we will notify you. At that time the governing body will need to officially approve the Water System Plan and send DOH documentation of plan approval by the governing body, such as a copy of the signed meeting minutes or a copy of the signed resolution. When the documentation is received we will send a letter documenting DOH approval.	The City will approve the water system plan when notified by Health and provide a copy of the signed meeting minutes at that time.	N/A

DOH Comment No.	DOH Comment	Water System Response	Page Number of Response
<p>Recommendations – The following recommendations do not affect whether the Water System Plan (WSP) can be approved. They are provided to help improve the content of the plan, eliminate minor inconsistencies, and provide an opportunity to clarify some non-typical content or circumstances.</p>			
	<p>Page ES-2 says the City intends to decommission well #4. It is not clear if this is the current well#4, or a well that remained when well#4 was re-drilled in 2001. Please clarify.</p>	<p>The plan has been revised to reflect decommissioning of old Well No. 4.</p>	<p>Page ES-2 Page 8-2</p>
	<p>Page 2-11 incorrectly states the medium growth rate was used from the 2003 comp plan.</p>	<p>The text has been corrected to reflect the projected growth rate used in the plan.</p>	<p>Page 2-11</p>
	<p>The DSL for 2012 is different from what was reported to the Department on the annual WUE Report. Contact Larry Granish at (360) 236-3141 to correct your 2012 report.</p>	<p>The City will address this with the Department of Health.</p>	<p>N/A</p>
	<p>Page 3-4, Paragraph 2. Identify all of the other Group A and B water systems in the City’s service area on a map. Specifically identify which of the systems (including PWS ID# if available) the City would like to consider for consolidation. DOH has a consolidation feasibility grant that can pay to study the costs and engineering needed to consolidate other Group A systems. Indicate in the plan if the City plans to apply for those grant funds. These systems also need to be notified that the City has a draft WSP update available for review.</p>	<p>Information is not readily available to provide a map that includes boundaries of other Group A and B water systems located within the City’s service area. Neighboring water systems have been added to Chapter 1.</p> <p>The Way S water system (ID#27676) has been identified in the plan as a potential water system consolidation project. Health denied the City’s application for grant funds for a consolidation feasibility study for this system. The City notified the neighboring Group A water systems identified by Michael Wilson, P.E. in an email from 11-26-15.</p>	<p>Page 1-15 Page 3-4</p>
	<p>Table 3-12. Include consolidation feasibility studies and projects as appropriate.</p>	<p>Feasibility study to investigate consolidation of the Way S Group A water system into the City’s water system added to Table 3-12.</p>	<p>Table 3-12</p>
	<p>Chapter 5. Include the declaration of covenants restricting the use of the land in each well’s sanitary control area. If the City has not developed these covenants, please include them under the Long-Term Contingency Planning section in Chapter 5.</p>	<p>Discussion added in Chapter 5.</p>	<p>Page 5-8</p>



# CITY OF OKANOGAN

OKANOGAN COUNTY,

WASHINGTON



## WATER SYSTEM PLAN



G&O #15012  
SEPTEMBER 2016



**Gray & Osborne, Inc.**  
CONSULTING ENGINEERS

## EXECUTIVE SUMMARY

The objectives of this water system plan update are to evaluate the performance and adequacy of the City of Okanogan's existing water supply and distribution system and to describe what steps the City must take to meet the demands of its six- and 20-year planning periods. This plan has been written to comply with WAC 246-290-100, the Washington State Department of Health's rules for developing a water system plan.

### PLANNING

The City's residential population, estimated at 2,606 in 2015, is projected to grow at a rate of 0.42 percent per year throughout the 20-year planning period to a population of approximately 2,833 by 2035. In addition, the City has an agreement to provide water to the Progressive Flats Water Association, which adds an estimated population of 147 to the 20-year projection for a total estimated population served of 2,980 in 2035. This population growth will increase the City's water system demands, in addition to the growth of commercial use which is expected to increase proportional to residential growth. The City's average day demand is projected to increase from 563,000 gallons per day (gpd) in 2015 to 612,000 gpd in 2035. Its maximum day demand requirement is projected to increase from 1,239,000 in 2015 to 1,346,000 gpd in 2035.

### WATER RIGHTS

The City plans to file change applications with the Washington State Department of Ecology to consolidate its existing water rights to give the City greater flexibility in managing its water resources.

The City includes areas within the boundaries of the Confederated Tribes of the Colville Reservation (CTCR). The City plans to work with the CTCR to review and coordinate water rights applications as deemed beneficial to preserve, enhance and support predictable growth within this area of joint planning jurisdiction.

### CAPITAL IMPROVEMENTS

The City has identified the following capital improvements for its six- and 20-year improvement schedule (improvement numbering corresponds to improvements and figures in Chapter 8):

#### *Telemetry*

- 1. Telemetry System Improvements** – The City plans to upgrade the existing telemetry control system with a new base station master computer, PLC at the base station master computer, HMI software, and new programming in order to increase reliability and to add functionality. The new system will control reservoir levels, record data and have the capability of performing additional functions for anticipated needs, such as chlorine residual monitoring at each well site and flow



metering of the water delivered to the Progressive Flats Water Association, and to include flow metering from all sources and telemetry for the new Murray Street Booster Pump Station **(6-year plan)**.

### *Source Improvements*

2. **Watercress Springs Feasibility Study** – Feasibility study to investigate required improvements and costs to rehabilitate the Watercress Springs source, storage and water distribution system **(6-year plan)**.
3. **Well Improvements** - Install manual transfer switches, motor soft starts and provide ports for groundwater depth measurements at Wells No. 2, 3, 4, and 5 and one portable standby generator capable of serving any of these wells. **(6-year plan)**.
4. **Well Decommissioning** – Decommission old City Well No. 1, old Well No. 4, and an old well discovered on City property at the Okanogan Sports Complex **(6-year plan)**.
5. **Well No. 3 Inspection** – Remove submersible turbine pump and perform video inspection of Well No. 3 **(6-year plan)**.
6. **Well No. 4 Bypass** – Bypass piping improvements at Well No. 4 **(6-year plan)**.
7. **Well No. 6 (Riverwalk Well)** - Investigate feasibility to develop the privately-owned Well No. 6 (Riverwalk Well). This improvement would replace the 48-foot deep well with a new 12” diameter well constructed to municipal standards **(20-year)**.

### *Treatment*

8. **Arsenic Treatment Facility Feasibility Study** – Feasibility study to investigate alternatives and make recommendations for the collection and disposal of arsenic-laced sludge from the arsenic treatment facility **(6-year plan)**.
9. **Arsenic Treatment Facility Improvements** – Construct sludge collection and disposal facilities in accordance with the findings and recommendations of the arsenic treatment facility feasibility study **(6-year)**.
10. **Well Chlorination Improvements** - Install chlorination facilities at the City’s active well sites **(20-year plan)**.

### *Storage*

11. **Murray Reservoir** - Construct 200,000-gallon reservoir in the Murray pressure zone. The project includes construction of a transfer station for water transfer to the lower zone, as necessary; pressure reducing valve stations in order to provide

adequate service throughout the pressure zones; approximately 5,000 feet of 12” PVC C900 water main, valves and appurtenances. These improvements are needed to provide adequate pressures and fire suppression storage for the Murray pressure zone as well as provide additional fire suppression storage for the Lower pressure zone. **(20-year plan)**.

12. **West Reservoirs Improvements** - Install security fencing and gates to limit access to the West reservoirs and replace the existing wood-frame truss roof on West Reservoir No. 1 **(20-year plan)**.
13. **East Reservoir Improvements** - Clean and inspect the East Reservoir and install a center fill pipe (similar to the North Reservoir) to improve mixing **(20-year plan)**.

### *Distribution*

14. **Murray Street Master Meter** – Demolish the existing building and install the master meter in a vault **(6-year plan)**.
15. **Murray Street Booster Pump Station** – Construct new Murray Street booster pump station capable of serving future Murray Reservoir, including two booster pumps with pitless adapters, building for electrical and control equipment, including variable frequency drive motors **(6-year plan)**.
16. **5<sup>th</sup> Avenue Water Main Replacement** – This improvement consists of the replacement of the existing 6” CI water line with a new 12” water line on 5<sup>th</sup> Avenue from Spruce Street to Oak Street **(6-year plan)**.
17. **Elmway Water Main Extension (Phase 3)** – This improvement consists of the construction of a new 12” water line on 2<sup>nd</sup> Avenue (SR 215) from River Street to Shell Rock Point to extend municipal water service to the City’s northern city limits and eventual connection (at a location to be determined) with the North River Crossing **(6-year plan)**.
18. **1<sup>st</sup> Avenue Water Main** – This improvement consists of the replacement of the existing 6” AC water line with a new 8” water line on 1<sup>st</sup> Avenue from Ione Street to Conconully Street and the construction of a new 8” water line from Conconully Street to Tyee Street to provide system looping **(6-year plan)**.
19. **South Okanogan Water System Improvements** – This improvement consists of the replacement of existing 6” water lines on Ione Street, Gordon Street, 2<sup>nd</sup> Avenue, Nickell Street, and at the entrance to the City’s wastewater treatment plant, with new 8” and 12” water lines to improve fire flow in these areas **(6-year plan)**.
20. **Rodeo Trail Water Main Replacement** – This improvement consists of the replacement of existing 2 ½” and 8” water lines on Rodeo Trail with a new 12” water line and extension to the Central Valley Sports Complex to improve fire flows in this area and provide for future expansion to the north **(6-year plan)**.

21. **Highland Drive Water Main Replacement** – This improvement consists of the replacement of existing 2 ½” GI water pipe on Highland Drive and east to Richlyn Avenue with new 8” water main to improve fire flows in this area (**6-year plan**).
22. **Tacoma Street/Spokane Street Water Main Loop** – This improvement consists of the replacement of existing 4” AC and CI water pipe with new 8” water lines on Tacoma Street, 4<sup>th</sup> Avenue, and Spokane Street to improve fire flows in this area (**6-year plan**).
23. **2nd Avenue South Water Main Replacement** – This improvement consists of the replacement of existing 6” AC and DI water main pipe on 2<sup>nd</sup> Avenue from Ione Street to Rose Street with new 8” water main (**20-year plan**).
24. **Viewmont Drive Water Main Replacement** – This improvement consists of the replacement of the existing 6” AC water main on Viewmont Drive from Highland Drive to Crestview Drive with new 8” water main pipe and the extension of 8” water main on Delmav to Crestview Drive to improve fire flows in the area, provide looping on Delmav, and improve water transmission to the central grid from the Highland Reservoir (**20-year plan**).
25. **3<sup>rd</sup> Avenue North Water Main Replacement** – This improvement consists of the replacement of the existing 6” AC and CI water line on 3<sup>rd</sup> Avenue North from June Street to Greta Street with new 8” water main to improve fire flows in the area (**20-year plan**).
26. **Mill Street Water System Improvements** – This improvement consists of the construction of an 8” water line on Mill Street and 9<sup>th</sup> Avenue to improvement fire flows in the area (**20-year plan**).
27. **Airport Booster Pump Station** – This improvement consists of the construction of a new booster pump station to address fire flow deficiencies near the airport (**20-year plan**).
28. **2<sup>nd</sup> Avenue Water System Improvements** – This improvement consists of the installation of an 8” water main on 2<sup>nd</sup> Avenue from Oak Street to Greta Street (**20-year plan**).
29. **North River Crossing** – This improvement consists of the installation of a 12” water main crossing the Okanogan River and eventual connection (at location to be determined location) to the Elmway Water Main Extension Phase 3 (**20-year plan**).
30. **4<sup>th</sup> Avenue Water Main and Valve Replacement** – This improvement consists of the installation of an 8” water main on 4<sup>th</sup> Avenue from Pine Street to Lower Pine Street and the replacement of the valve cluster located at the intersection of 4<sup>th</sup> Avenue and Queen Street (**20-year plan**).

A summary of the 2015 costs for each of the improvements planned for the next six years is provided in Table ES-1 (improvements outside of the six-year planning period are also shown in this table).

**TABLE ES-1**  
**Capital Improvement Plan**

PROJECT	OCT. 2015 COST <sup>(1)</sup>	YEAR PLANNED						
		'16	'17	'18	'19	'20	'21	>'21
<b>MISCELLANEOUS</b>								
Water Rights Consolidation	\$10,000	X						
Source Protective Covenants	-----	X						
Progressive Flats Agreement Review	-----	X						
<b>TELEMETRY</b>								
1. Telemetry System Improvements	\$60,000				X			
<b>SOURCE</b>								
2. Watercress Springs Feasibility Study	\$15,000		X					
3. Well Improvements	\$246,000			X				
4. Well Decommissioning	\$222,000			X				
5. Well No. 3 Inspection	\$36,000			X				
6. Well No. 4 Bypass	\$28,000			X				
7. Well No. 6 (Riverwalk Well)								X
<b>TREATMENT</b>								
8. Arsenic Treatment Facility Feasibility	\$5,000	X						
9. Arsenic Treatment Facility Improve.	\$50,000		X					
10. Well Chlorination Improvements								X
<b>STORAGE</b>								
11. Murray Reservoir								X
12. West Reservoirs Improvements								X
13. East Reservoir Improvements								X
<b>DISTRIBUTION</b>								
14. Murray Street Master Meter	\$60,000	X						
15. Murray Street Booster Pump Station	\$467,000						X	
16. 5 <sup>th</sup> Avenue Water Main Replacement	\$466,000	X						
17. Elmway Water Main Ext. Phase 3	\$877,000		X					
18. 1 <sup>st</sup> Avenue Water Main	\$1,395,000						X	

**TABLE ES-1 con't**

**Capital Improvement Plan**

PROJECT	OCT. 2015 COST <sup>(1)</sup>	YEAR PLANNED						
		'16	'17	'18	'19	'20	'21	>'21
<b>DISTRIBUTION CON'T</b>								
19. South Okanogan Water System Improvements	\$1,097,000						X	
20. Rodeo Trail Water Main Replacement	\$729,000						X	
21. Highland Dr Water Main Replacement	\$224,000						X	
22. Tacoma/Spokane Streets Water Loop	\$623,000						X	
23. 2 <sup>nd</sup> Avenue S. Water Main Replacement								X
24. Viewmont Dr Water Main Replacement								X
25. 3 <sup>rd</sup> Avenue N. Water Main Replacement								X
26. Mill Street Water System Improvements								X
27. Airport Booster Pump Station								X
28. 3 <sup>rd</sup> Avenue Water System Improvements								X
29. North River Crossing								X
30. 4 <sup>th</sup> Avenue Water Main Replacement								X

6-year capital improvement only; construction costs for 20-year capital

**FINANCING**

Financing of the proposed six-year capital improvements shown on Table ES-1 will most likely include a mix of City funds with grant/loan packages from USDA Rural Development (RD) and Health's Drinking Water State Revolving Fund (DWSRF). For this Plan, it has been assumed that the City will fund the smaller improvement projects (Improvement Nos. 1, 2, 5, 6, 8, 9, and 14) with DWSRF funds sought for the remaining well improvement projects (Improvement Nos. 3 and 4), and RD grant/loan funds sought for the remaining six-year improvements.

# TABLE OF CONTENTS

## CHAPTER 1: DESCRIPTION OF WATER SYSTEM

OWNERSHIP AND MANAGEMENT .....	1-1
HISTORY AND BACKGROUND.....	1-1
EXISTING FACILITIES .....	1-2
Sources.....	1-2
Storage .....	1-5
Booster Pumping Stations.....	1-7
Transfer Station.....	1-8
Transmission and Distribution.....	1-8
Treatment and Disinfection.....	1-9
Telemetry and Controls.....	1-9
WATER RIGHTS.....	1-9
Ground Water Rights .....	1-10
Water Right Claims.....	1-11
Progressive Flats Water Rights.....	1-13
Dickson Water Right.....	1-13
Irrigation Supply .....	1-14
PLANNING AND POLICIES .....	1-14
Related Planning Documents .....	1-14
Watershed Planning .....	1-14
SERVICE AREA CHARACTERISTICS.....	1-15
Existing and Future Service Area .....	1-15
Zoning.....	1-15
Service Area Policies and Conditions of Service .....	1-15
Neighborhood Water Purveyors .....	1-15
Duty to Serve .....	1-16
Service Area Policies and Conditions of Service .....	1-16

## CHAPTER 2: BASIC PLANNING DATA

HISTORICAL DATA.....	2-1
Historical Population .....	2-1
Service Connections.....	2-2
HISTORICAL WATER USE.....	2-2
Average Day Demand (ADD) .....	2-2
Maximum Day Demand (MDD).....	2-5
Peak Hour Demand (PHD) .....	2-6
Consumption History .....	2-6
Distribution System Leakage.....	2-8
Equivalent Residential Units.....	2-9
East Side Equivalent Residential Units.....	2-10
Largest Water Users.....	2-10
Irrigation Water Consumption .....	2-11
PROJECTED LAND USE, FUTURE POPULATION, AND WATER DEMANDS.....	2-11
Projected Population .....	2-11
Projected ERU's.....	2-12
Projected ADD, MDD, and PHD.....	2-13
Water Use Efficiency .....	2-14

## **CHAPTER 3: WATER SYSTEM ANALYSIS**

SYSTEM DESIGN STANDARDS .....	3-1
General Facility Standards.....	3-1
Construction Standards .....	3-3
WATER QUALITY ANALYSIS .....	3-3
FACILITY ANALYSIS.....	3-4
Source .....	3-4
Storage .....	3-8
Booster Pumping Stations.....	3-14
Transmission and Distribution.....	3-17
Water System Physical Capacity Analysis .....	3-19
OPERATION AND MAINTENANCE ANALYSIS.....	3-21
SYSTEM DEFICIENCIES AND PROPOSED IMPROVEMENTS.....	3-21

## **CHAPTER 4: WATER USE EFFICIENCY**

BACKGROUND.....	4-1
Production and Source Meters.....	4-2
Service Meters and Water Consumption .....	4-2
Interties .....	4-2
WATER USE EFFICIENCY PROGRAM.....	4-2
Current Water Use Efficiency Program.....	4-2
New WUE Goals.....	4-3
WUE Measures .....	4-3
WUE Education .....	4-4
Evaluating WUE Effectiveness.....	4-4
Distribution System Leakage.....	4-5
Water Loss Control Action Plan.....	4-6
Conservation Rate Structure .....	4-7
Water Reclamation.....	4-8
Water Supply Characteristics.....	4-8

## **CHAPTER 5: SOURCE WATER PROTECTION**

GENERAL .....	5-1
OBJECTIVE .....	5-1
WELLHEAD PROTECTION AREA DELINEATIONS.....	5-1
Definition of a Wellhead Protection Area .....	5-1
Calculated Fixed Radius (CFR) Model.....	5-3
POTENTIAL CONTAMINANT SOURCES .....	5-4
Inventory of Potential Contaminant Sources .....	5-4
Notifications.....	5-5
Notification to Regulatory Agencies and Local Governments.....	5-5
Notification to Local Emergency Incident Responders .....	5-6
LONG-TERM CONTINGENCY PLANNING.....	5-7
Drill New Wells .....	5-7
Groundwater Treatment .....	5-7
Interconnection .....	5-7
Water Conservation .....	5-7
Dual Systems .....	5-7
Surface Water Treatment .....	5-8

Protective Covenants .....	5-8
OKANOGAN WELLHEAD PROTECTION MANAGEMENT .....	5-8

**CHAPTER 6: OPERATION AND MAINTENANCE**

SYSTEM PERSONNEL .....	6-1
OPERATION AND MAINTENANCE PROGRAM.....	6-2
RECORD KEEPING .....	6-4
COMPLAINT RESPONSE .....	6-4
SAFETY PROCEDURES .....	6-4
DEFICIENCIES.....	6-5

**CHAPTER 7: CONSTRUCTION STANDARDS**

REQUIREMENTS FOR DEVELOPER-CONSTRUCTED IMPROVEMENTS .....	7-1
WATER .....	7-2
Water Service Materials.....	7-5
WATER MAIN STANDARD PLANS INDEX.....	7-6

**CHAPTER 8: CAPITAL IMPROVEMENT PROGRAM**

WATER RIGHTS.....	8-1
AGREEMENTS.....	8-1
TELEMETRY .....	8-1
SOURCE IMPROVEMENTS .....	8-2
TREATMENT.....	8-2
STORAGE .....	8-3
DISTRIBUTION.....	8-3
SCHEDULE.....	8-6

**CHAPTER 9: CAPITAL IMPROVEMENT FINANCING**

EXISTING RATES AND CHARGES .....	9-1
MONTHLY CHARGES PER CUSTOMER CLASS .....	9-2
PAST AND PRESENT FINANCIAL STATUS .....	9-2
FUNDING SOURCES .....	9-5
SIX-YEAR FINANCING PLAN .....	9-6



## LIST OF TABLES

<u>No.</u>	<u>Table</u>	<u>Page</u>
1-1	Existing Water System: Sources .....	1-4
1-2	Existing Water System: Storage .....	1-7
1-3	Existing Water System: Booster Pumping Stations.....	1-8
1-4	Existing Water System: Transmission & Distribution Piping .....	1-9
1-5	Water Rights Summary.....	1-12
1-6	Service Area Policies .....	1-17
2-1	2014 Customer Accounts.....	2-2
2-2	2006 - 2014 Average Daily Demand (ADD).....	2-3
2-3	2009 - 2014 Maximum Day Demand (MDD) .....	2-6
2-4	2010 - 2014 Total Water Consumption .....	2-7
2-5	2010 - 2014 Residential Water Consumption.....	2-7
2-6	2010 - 2014 Distribution System Leakage .....	2-9
2-7	2014 Equivalent Residential Units.....	2-10
2-8	2014 Largest Water Users.....	2-11
2-9	Projected ERUs.....	2-12
2-10	Projected ADD, MDD, and PHD.....	2-13
2-11	Projected ADD, MDD, and PHD with Conservation .....	2-15
2-12	Projected Savings with DSL Improvements and Reduced Consumption.....	2-15
3-1	General Facility Requirements .....	3-2
3-2	Source Production Capacity Analysis.....	3-4
3-3	2035 Source Production Capacity Analysis.....	3-5
3-4	Water Rights Self-Assessment.....	3-7
3-5	Storage Volume Components .....	3-10
3-6	Storage Volume Summary .....	3-11
3-7	2035 Storage Analysis – Lower Pressure Zone .....	3-12
3-8	2035 Storage Analysis – Highland Pressure Zone.....	3-13
3-9	2035 Storage Analysis – Murray Pressure Zone.....	3-14
3-10	Murray Pressure Zone Connections 2035 Projection .....	3-15
3-11	Projects Started and/or Substantial Interest Shown, 0-10 Years.....	3-19
----	Worksheet 6-1: ERU Determinations .....	3-20
3-12	Summary of System Deficiencies and Proposed Improvements .....	3-22
4-1	Summary of Water Use Efficiency Rule Requirements .....	4-1
4-2	Mandatory Water Use Efficiency Measures.....	4-3
4-3	Demand-Side Water Use Efficiency Measures.....	4-4
4-4	Projected Water Demands with Water Savings .....	4-5
4-5	Inclined Block Rate Structure Pros and Cons.....	4-7
5-1	Calculated Fixed Radius Wellhead Protection Areas .....	5-4
6-1	Operation & Maintenance Program Elements .....	6-1
6-2	Water System Personnel .....	6-1
6-3	Operation and Maintenance Practices.....	6-2
6-4	Normal Equipment Settings .....	6-3
6-5	Supplies and Suppliers.....	6-3
6-6	Record Keeping Practices.....	6-4
6-7	Operation and Maintenance Improvements .....	6-5
8-1	Capital Improvement Plan .....	8-6

## LIST OF TABLES (Continued)

<u>No.</u>	<u>Table</u>	<u>Page</u>
9-1	2016 Water Service Rates for First 5,000 gallons per Month.....	9-1
9-2	2016 Water Service Volume Charges.....	9-1
9-3	2016 Connection Charges.....	9-2
9-4	Average Monthly Bill per Customer Class.....	9-2
9-5	Water Utility Historical Revenue and Expenditures (Summarized from the City’s Revenue and Expenditure Reports) .....	9-4
9-6	Possible Funding Sources .....	9-6
9-7	Rate Impacts Funding Alternatives.....	9-8
9-8	Monthly Bill Comparison Versus Other Eastern Washington Cities .....	9-9
9-9	Six Year Financing Plan .....	9-10

## LIST OF FIGURES

<u>No.</u>	<u>Figure</u>	<u>Page or Follows Page</u>
1-1	Existing System .....	1-2
1-2	Hydraulic Profile.....	1-2
1-3	Water Service Areas .....	1-16
1-4	Zoning Map.....	1-16
2-1	Historical Population .....	2-1
2-2	2009–2014 Monthly Water Production .....	2-4
2-3	2014 Monthly Water Production by Well.....	2-5
2-4	2014 Seasonal Variations in Consumption by Customer Classification .....	2-8
3-1	2035 Fireflow Deficiencies.....	3-18
3-2	2035 Fireflow Deficiencies with Capital Improvements .....	3-18
5-1	Potential Contaminant Sources Within Travel Zones.....	5-4
----	Water System Facilities Figures .....	6-5
----	Standard Plan Nos. 1-17 .....	7-6
8-1	Capital Improvements.....	8-7

## LIST OF APPENDICES

APPENDIX A:	WATER FACILITIES INVENTORY
APPENDIX B:	COMPRHENSIVE MONITORING PLAN
APPENDIX B-1:	WATER QUALITY MONITORING REPORT
APPENDIX B-2:	COLIFORM MONITORING PLAN
APPENDIX C:	ANNUAL OPERATING PERMIT
APPENDIX D:	SANITARY SURVEY AND DOH CORRESPONDENCE
APPENDIX E:	CONSUMER CONFIDENCE REPORT
APPENDIX F:	CROSS CONNECTION CONTROL PROGRAM
APPENDIX G:	EMERGENCY RESPONSE PLAN
APPENDIX H:	CONSISTENCY STATEMENTS
APPENDIX I:	SEPA CHECKLIST
APPENDIX J:	NESTING APPROVAL LETTER
APPENDIX K:	WATER RIGHTS DOCUMENTATION
APPENDIX L:	COST ESTIMATES

## **LIST OF APPENDICES (Continued)**

APPENDIX M:	AGREEMENT WITH PFWA
APPENDIX N:	RESOLUTION
APPENDIX O:	COUNCIL MEETING DOCUMENTATION
APPENDIX P:	NOTICE TO ADJACENT UTILITY PROVIDERS

# CHAPTER 1

## DESCRIPTION OF WATER SYSTEM

This chapter presents information on ownership and management of the water system, system background data, an inventory of existing system facilities, related planning documents, existing and future service areas and characteristics, and service area agreements and policies.

### OWNERSHIP AND MANAGEMENT

The City of Okanogan, which is governed by a Mayor and City Council, owns, operates and manages the City's water system. The Washington State Department of Health water system identification number for the water system is 63200M. City staff involved in management of the water system, as well as contact information for the City, follows:

#### *Personnel*

Craig Attwood	Clerk-Treasurer
Shawn Davisson	Public Works Director
Loren Howell	Water System Operator (Water Distribution Manager II, Water Treatment Plant Operator I, Water Distribution Specialist, and Cross-Connection Control Specialist)
Barry Featherly	Assistant Water System Operator (Water Distribution Manager II, Cross-Connection Control Specialist, Water Treatment Plant Operator In-Training)

#### *Contact Information*

City of Okanogan  
120 Third Ave N  
P.O. Box 752  
Okanogan, WA 98840  
(509) 422-3600

### HISTORY & BACKGROUND

The City of Okanogan is located in north central Washington in the Okanogan River Valley. The City sits on a narrow river plain with steeply rising side slopes. The City's retail area lies mostly to the west of the Okanogan River, with State Route 97 (SR 97) running parallel to the river on its east bank. The Oak Street bridge and the State Route 20 bridge provide access to SR 97. The eastern portion of the City is located on tribal land, with the Colville Confederated Tribal boundary coinciding with the center of the Okanogan River. The City continues to grow primarily to the south and west, with limited growth to the North due to the close proximity to Omak. Growth is also limited to the east. The commercial and industrial areas of the city are located primarily in east Okanogan with the residential areas located primarily on the west along the base of the surrounding hills.

The climate in the Okanogan area is influenced by the rain shadow effect of the Cascades. Conditions throughout the region are characterized by warm, dry summers and relatively cold winters. Summer temperatures vary between an average minimum of 40°F to an average maximum of 92°F. Winter temperatures vary between an average minimum of 17°F to an average maximum of 40°F. The average annual precipitation for the region is 11 inches. Most of the precipitation falls in the form of snow, with higher elevations accumulating more than 100 inches.

Okanogan began as a trading post established by Frank J. Cummings in 1886, located near the mouth of Salmon Creek. As settlement near the post grew, it became the first city in the Okanogan Valley, known then as Alma, a name that is still borne by Alma Park, located in the City of Okanogan. The Okanogan River and area springs were the earliest water sources used by City residents.

As the City grew, the City changed its name to Pogue in 1905, to honor one of the areas earliest orchardists. In 1907 the City was incorporated with a name change, due to the difficulty in pronouncing Pogue; the City changed its name to Okanogan, taken from Salish Indian language meaning “rendezvous.” At the same time, the City first started to use Watercress Springs as a municipal supply source and a rudimentary concrete distribution system was developed. In 1914, after a countywide election, the City was awarded the county seat of government of the largest geographic county in the State of Washington. The City continued to use Watercress Springs as the sole municipal supply until the late 1920s when the Park Well was developed. This well was located near Alma Park and received its supply from shallow groundwater fed by the Okanogan River. In 1939, Well No. 1 was drilled to provide additional source capacity. Major source, storage and distribution system improvements continue to present day.

## **EXISTING FACILITIES**

Okanogan’s water system consists of four active wells, five active reservoirs, two booster stations, a transfer station, and approximately 24 miles of transmission and distribution piping. An inventory of major system components is presented herein. A topographic map showing the existing water system is provided on Figure 1-1. The City’s water system has three pressure zones. Photographs of the City’s existing well houses, reservoirs, booster stations, and transfer station are presented in Chapter 6, Operation and Maintenance.

## **SOURCES**

The City’s domestic water is supplied from four groundwater wells (Well Nos. 2, 3, 4, and 5) as shown on Figure 1-2.

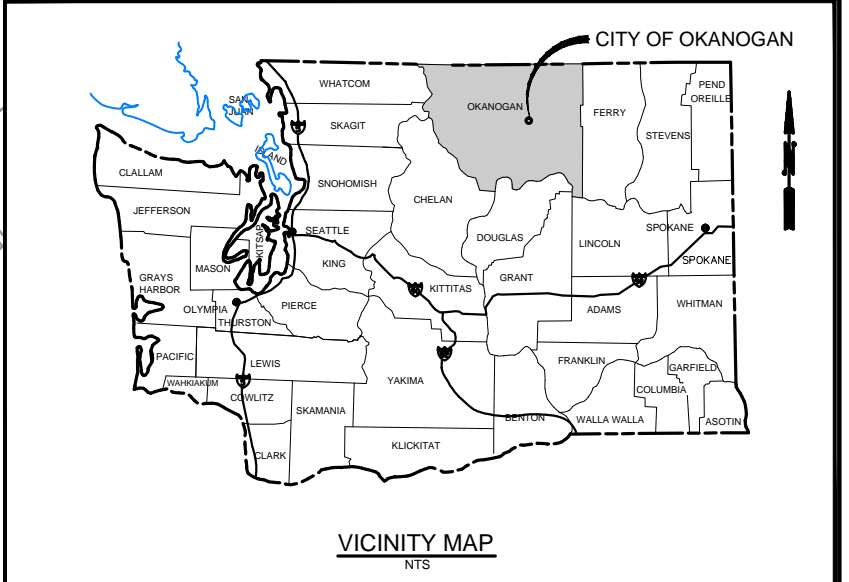
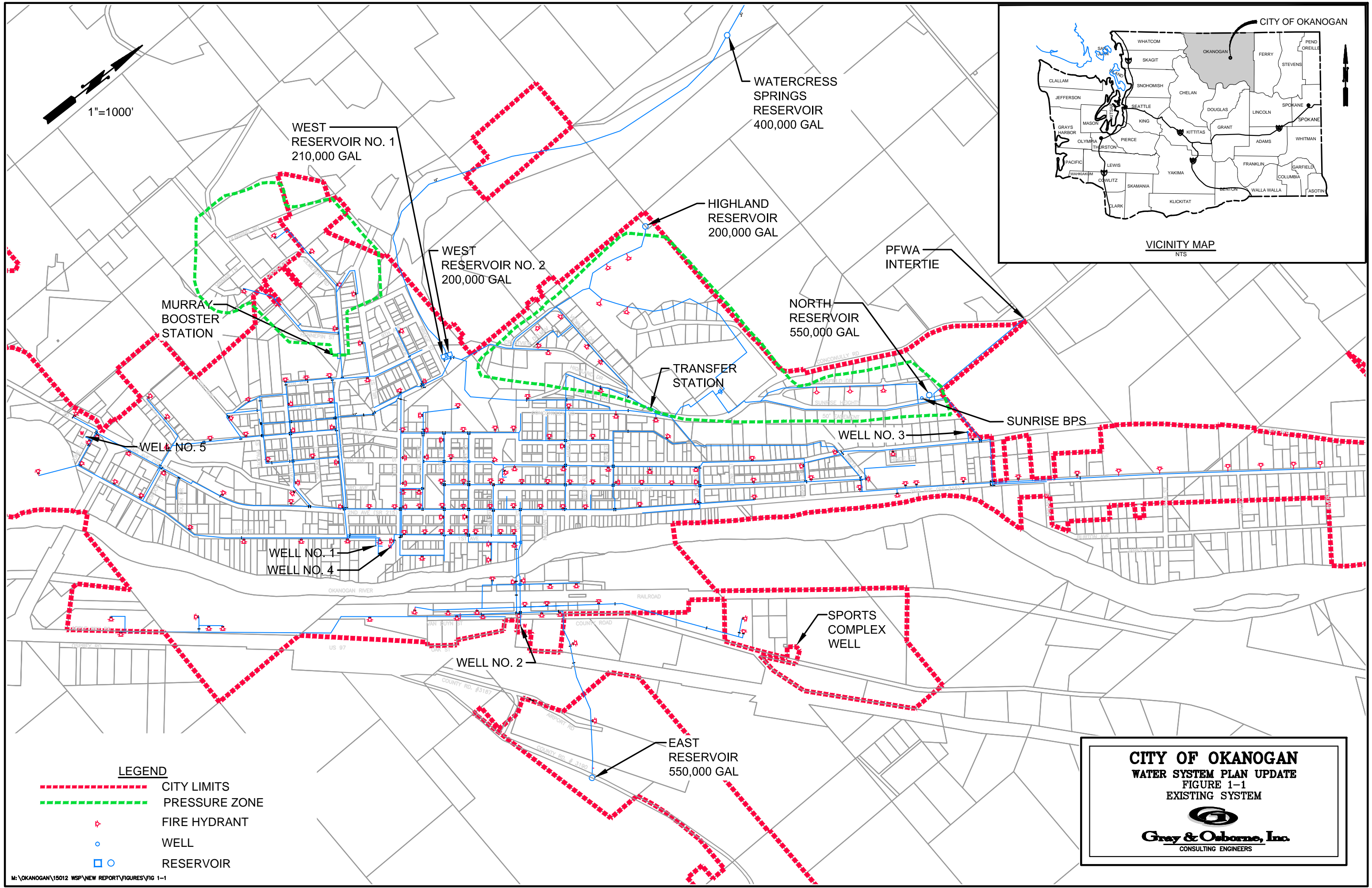

**LEGEND**

- - - CITY LIMITS
- - - PRESSURE ZONE
- ⊕ FIRE HYDRANT
- WELL
- ◻ RESERVOIR

**CITY OF OKANOGAN**  
**WATER SYSTEM PLAN UPDATE**  
 FIGURE 1-1  
 EXISTING SYSTEM

**Gray & Osborne, Inc.**  
 CONSULTING ENGINEERS

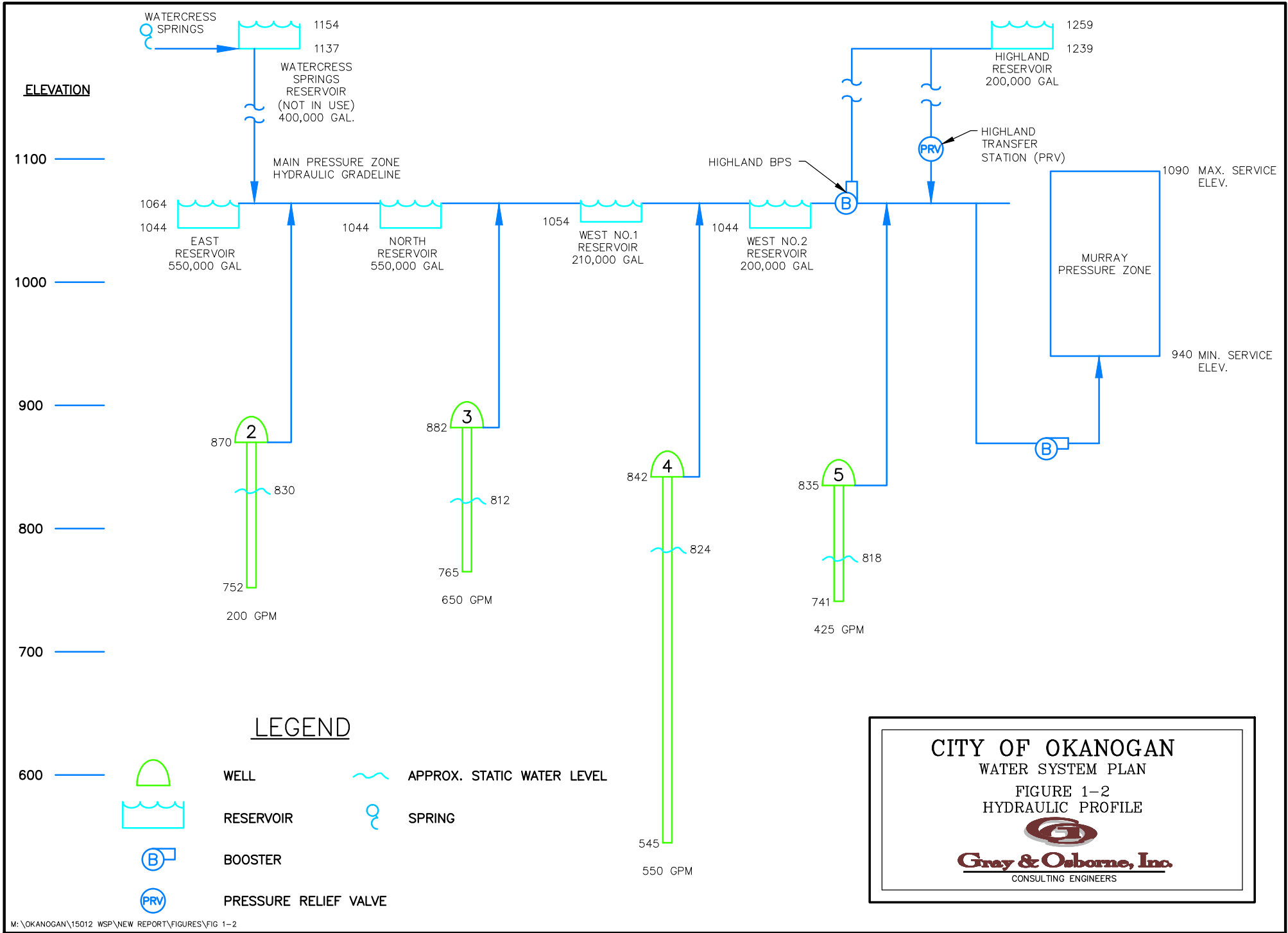

### **Sources Not Currently in Use:**

Watercress Springs is the City's original water supply, but is not currently being used as a domestic water source since the springs were determined to be Groundwater under the Direct Influence of Surface Water (GWI) in 2003. These springs are located one mile northwest of the City and adjacent to Salmon Creek on 18 acres of property owned by the City. The springs are also known as Salmon Creek Springs and Shull Springs. The property is approximately 2,300 feet in length and averages about 400 feet in width. The property was annexed to allow the City policing powers to control the property.

The Park Well was drilled in the 1920s to augment supply from the Watercress Springs. The well was located on the western bank of the Okanogan River near Alma Park. The hand-dug well was approximately 3 feet in diameter and 30 feet deep and was equipped with two pumps (300 and 225 gallons per minute (gpm)). The well pumped into a cistern beneath the City sidewalk from which the water was pumped. This well has not been used since the 1970s and water rights associated with this well were transferred to Well No. 1 through the Washington State Department of Ecology (DOE).

Well No. 1, drilled in 1939, is located in Alma Park near the City swimming pool. The well is located on the east side of 1<sup>st</sup> Avenue, between Tyee and Conconully Streets, approximately 150 feet south of Salmon Creek. Use of this well was discontinued in 1985 and the majority of its water rights transferred to Well No. 5 when well production decreased to less than 50 gpm. The pump was removed from the well and the well casing sealed with a steel plate.

### **Sources Currently in Use:**

Well No. 2, originally drilled in 1947 and re-drilled in 2000, is located in East Okanogan on City-owned property at the northeast quadrant of the intersection of Oak and Van Duyn Streets.

Well No. 3, drilled in 1963, is located on the west edge of 4<sup>th</sup> Avenue, north of Hinde Street, at the base of the hill and below the North Reservoir.

Well No. 4, originally drilled in 1976 and re-drilled in 2001, is located on City-owned property at the intersection of 1<sup>st</sup> Avenue and Tyee Street, immediately adjacent to Salmon Creek. This well is equipped with a flow control valve and pumps to the City's arsenic treatment facility. The wellhead is equipped with a pitless adapter with a below ground discharge.

Well No. 5, drilled in 1987, is located at the intersection of Ione Street and 2<sup>nd</sup> Avenue. This well is equipped with a Cla-Val flow control valve located in a vault on the well site. The wellhead is equipped with a pitless adapter with a below ground discharge.



Physical addresses for the City's water sources are as follows:

Well No. 1 (inactive):	Alma Park; 601 1 <sup>st</sup> Avenue South
Well No. 2:	State Patrol Park; 100 Van Duyn Street
Well No. 3:	North Well; 1537 4 <sup>th</sup> Avenue North
Well No. 4:	Arsenic Plant; 51 Tyee Street
Well No. 5:	Timm's Park; 149 Ione Street
Watercress Springs (inactive):	Salmon Creek Road

**TABLE 1-1**

**Existing Water System: Sources<sup>(1)</sup>**

Parameter	Well No. 1 <sup>(2)</sup>	Well No. 2	Well No. 3	Well No. 4	Well No. 5	Watercress Springs <sup>(3)</sup>
DOH Source No./ID	S 01 49G013	S 02 49G014	S 03 49G015	S 04 49G016	S 06 49G053	S 05
Certification Number	CG4- GWC266D	CG4- CWC369A	G4- *06878CWRIS	G4-23854C	G4-29193P CG4- GWC369A	S4- 000052C1
DOE Well Tag No.	---	ABR535	AGJ158	AGJ157	AGJ156	AGJ159
Source Status	Inactive 9/13/1995	Active	Active	Active	Active	Inactive 7/2/2003
Type of Use	Emergency	Permanent	Seasonal	Seasonal	Permanent	Permanent
Year Drilled or Redrilled	1939	1947 2000	1963	1976 2001	1987	1908
Well Depth (ft)	90	118	117	297	94	---
Wellhead Ground Elev. (ft) <sup>(4)</sup>	840	870	882	842	835	1170
Rated Pump Capacity (gpm)	---	200	650	550	425	Gravity Flow
Actual Flow Rate (gpm)	---	200	650	550	425	150-280 Avg. 200 <sup>(5)</sup>
Static Water Level (ft)	---	40	70	18	17	---
Well Casing Diameter (in)	8	12	12	12	18	---
Casing Description	8" set @ 47'	Sch 40, 4" PVC 2.5' to 215'	12" from 0' to 117'	Welded 12" from 2' to 252.5'	18" Welded	---
Surface Seal Description	Unknown	Concrete Seal 8" to 3'	Unknown	Bentonite to 25'	Cement + 5% Bentonite 6' to 25'	---
Pump Type	Removed	Submersible	Submersible	Submersible	Submersible Turbine	---
Motor Characteristics	---	25 hp	60 hp	75 hp	50 hp	---

- 1) Information provided by the Department of Ecology Well Logs and Water Rights
- 2) Records indicate this well had problems with silting and sand which reduced the capacity so an application for change was filed to change the point of withdrawal to Well No. 5.
- 3) The City has temporarily inactivated this source.
- 4) MSL Elevation +/- 10 feet.
- 5) Historical information as provided by the City.

## STORAGE

The City of Okanogan has five reservoirs in service, the characteristics of which are summarized in Table 1-2. The City's current total water storage capacity is 1,710,000 gallons, consisting of the volumes from the East Reservoir, North Reservoir and the West Reservoirs No. 1 and 2 and the Highland Reservoir. The East Reservoir, North Reservoir and the West Reservoirs No. 1 and 2 are all on the same hydraulic grade line as indicated on Figure 1-2. The Highland Reservoir, located in a higher pressure zone, is supplied by the Sunrise booster pump station. The City's Watercress Springs Reservoir is currently out of service.

The 550,000-gallon East Reservoir is located on the east side of the airport on City-owned property. The reservoir is connected to the City water system by a 16-inch and 12-inch water main. The 16-inch main extends across the full width of the airport to reduce head loss through this level section of the pipeline profile. This reservoir is equipped with a telemetry altitude valve designed to automatically close to prevent reservoir overflows. The piping at the reservoir also includes a check valve in the altitude valve bypass line. The function of the check valve is to operate in parallel with the altitude valve and thereby permit a higher rate of water withdrawal from the reservoir. On the reservoir filling cycle, the check valve is closed, and all of the water is forced to pass through the controlling altitude valve.

The East Reservoir is a reinforced concrete circular dome-roofed structure partially buried in the hillside with the site enclosed by fencing. This structure is painted orange and white in conformance with Federal Aviation Administration (FAA) requirements for airports. The reservoir is approximately 66 feet in diameter, with a water depth of 20 feet. It was constructed in 1976, under a combination of the Farmers Home Administration (FMHA) and the State Department of Social & Health Services (DSHS) loan and grant programs.

The 550,000-gallon North Reservoir is partially buried in the hillside west of the City, just above Well No. 3. The reservoir is connected to the City's water system with a 12-inch water main. A combination overflow and drain line extends down the hill, parallel to the water main, and discharges into the Okanogan River. This reservoir is equipped with an altitude valve designated to automatically close to prevent reservoir overflows.

The North Reservoir is a concrete circular reservoir with a domed roof constructed in 1977, the year following construction of the East Reservoir. The structure is approximately 66 feet in diameter, and has a maximum water depth of 20 feet. Financing for reservoir construction included assistance from FMHA and DSHS.

The West Reservoirs are located adjacent to each other, west of the city center on a high bluff. West Reservoir No. 2 was reconstructed in 2005 and has a capacity of approximately 200,000 gallons. It is a partially buried cylindrical concrete reservoir, with a height of 20 feet. The West Reservoir No. 1 is believed to have been constructed in the 1950s. West Reservoir No. 1 has a capacity of 210,000 gallons and is rectangular in shape, with a trapezoidal cross section providing a minimal 10 feet of stored water depth.

The overflow elevations for the West Reservoirs are approximately 1,064 feet above sea level.

The West Reservoir overflow line discharges to a small pond to the north of the reservoirs for normal flows. The reservoir also has an overflow to Salmon Creek for auxiliary overflows.

The Highland Reservoir was constructed in 2005 and is of similar dimensions and geometry to the West Reservoir No. 2, with a nominal capacity of 200,000 gallons. This reservoir is an above ground cylindrical concrete reservoir with a height of 20 feet.

The Watercress Springs Reservoir has not been in use since 2003. It is a 400,000-gallon reservoir designed to store water conveyed from Watercress Springs. The reservoir is located approximately 1,000 feet downstream from the springs, east of the Salmon Creek County Road and east of Salmon Creek, on City-owned property. The reservoir and 12-inch steel transmission main were built in 1954.

The Watercress Springs Reservoir is a mostly buried, 66-foot diameter reinforced concrete reservoir with a flat roof and a hopper bottom, varying in depth from 13 to 17 feet. The overflow elevation of the reservoir is approximately 1,154 feet.

Physical addresses for the City's active reservoirs are as follows:

East Reservoir:	30 Okanogan Landfill Road
North Reservoir:	1411 Sunrise Heights
Highland Reservoir:	927 Parks Drive
West Reservoir No. 1 & 2:	96 Crestview Drive

**TABLE 1-2**

**Existing Water System: Storage**

<b>Parameter</b>	<b>East Reservoir</b>	<b>North Reservoir</b>	<b>West Reservoir No. 1<sup>(1)</sup></b>	<b>West Reservoir No. 2</b>	<b>Highland Reservoir</b>	<b>Watercress Springs Reservoir</b>
Status	Active	Active	Active	Active	Active	Not In Use
Year Constructed	1976	1977	1950s	2005	2005	1954
Type of Construction	Concrete	Concrete	Concrete	Concrete	Concrete	Concrete
Storage Capacity, gal	550,000	550,000	210,000	200,000	200,000	400,000
Diameter, ft	66	66	54 x 54	42	42	66
Height, ft	20	20	10	20	20	17
Base Elevation, ft msl	1,044	1,044	1,054	1,044	1,239	1,137
Overflow Elevation, ft msl	1,064	1,064	1,064	1,064	1,259	1,154
Altitude Valve	Yes	Yes	No	No	No	No
Pressure Zone	Main	Main	Main	Main	Zone 2	n/a

(1) West Reservoir No. 1 has sloping walls giving this reservoir a trapezoidal cross-section; reservoir height is approximate.

**BOOSTER PUMPING STATIONS**

The City operates two booster pumping stations (BPS); the Sunrise (Highland) Drive BPS and Murray Street BPS, as summarized in Table 1-3. The original Highland Drive BPS was constructed in 1976 at the intersection of Highland Drive and 6th Avenue. In 2005 this booster station was converted to a transfer station and the new Sunrise Drive BPS was constructed adjacent to the North Reservoir. This booster station serves the Highland Reservoir and Pressure Zone 2.

Physical addresses for the City’s booster stations are as follows:

Sunrise Booster Station: 1409 Sunrise Heights  
 Murray Booster Station: 873 Murray Street

**TABLE 1-3**

**Existing Water System: Booster Pumping Stations**

<b>Parameter</b>	<b>Sunrise Booster Station</b>	<b>Murray Street Booster Station</b>
Pressure Zone	2	3
Year Installed	2005	1976
Hydraulic Grade Line	1,254	1,170
Motor Horsepower (hp)	(2) 30 HP	(2) 5 HP
Motor Manufacturer	Franklin Electric	Franklin Electric
Rated Capacity (gpm)	350	190
Voltage, Phase	480, 3	220, 3
Pump Manufacturer	Simflo	Berkeley, Gould
Pump Series	SSJ7C	UHM
Fuse Amperage (amps)	45	16

**TRANSFER STATION**

The City has a transfer station located at 530 Highland Drive to automatically convey water from the Murray pressure zone (at a higher hydraulic grade line) to the lower pressure zone via a four-inch pressure relief valve (PRV). This valve is located in a vault near the intersection of Highland Drive and 6<sup>th</sup> Avenue. This transfer station allows the storage volume of the Highland Reservoir to serve as a back-up supply to the lower zone should pressures drop in the lower zone during an extreme high demand event such as during a fire.

**TRANSMISSION AND DISTRIBUTION**

The City has approximately 22 miles of transmission and distribution system piping. All new and replacement piping primarily consists of PVC. A summary of the City’s piping infrastructure is summarized in Table 1-4.

**TABLE 1-4**

**Existing Water System: Transmission & Distribution Piping**

Diameter (inches)	PVC (feet)	Steel (feet)	Asbestos-Cement (feet)	Galv. Iron (feet)	Cast Iron (feet)	Ductile Iron (feet)	HDPE (feet)	Unknown (feet)	Total Length (feet)	Percent of Total
1	0	0	0	0	0	0	0	545	545	<1%
2	0	0	0	701	0	0	0	3,026	3,727	3%
2.5	0	1,086	0	465	0	0	0	0	1,552	1%
4	0	0	2,081	0	2,842	0	0	848	5,771	5%
6	490	0	13,325	0	10,411	4,348	0	17,610	46,184	40%
8	2,309	0	22,235	0	5,876	631	0	830	31,881	28%
10	5,275	0	121	0	0	0	0	0	5,396	5%
12	4,294	8,721	5,237	0	0	1,319	241	0	19,812	17%
16	0	0	0	0	0	715	0	0	715	1%
<b>Total</b>	<b>12,368</b>	<b>9,807</b>	<b>42,998</b>	<b>1,166</b>	<b>19,129</b>	<b>7,012</b>	<b>241</b>	<b>22,860</b>	<b>115,581</b>	<b>100%</b>

**TREATMENT AND DISINFECTION**

The City does not currently chlorinate for disinfection unless there is a failed bacteriological test. When a failed test occurs, the City typically chlorinates the reservoirs in the area nearest the failed test sample location prior to performing additional testing.

In January 2001, the Environmental Protection Agency (EPA) tightened the standard for maximum contaminate level (MCL) for arsenic from 50 ppb (parts per billion) to 10 ppb. Groundwater from Well No. 4 was found to contain approximately 19 ppb arsenic. The City’s arsenic treatment facility, constructed in 2009, currently serves Well No. 4

**TELEMETRY AND CONTROLS**

The City’s water system has an automated telemetry system that was installed in 2001 and 2002. The system controller is located at the Public Works Office and the remote sites are installed at Well Nos. 2, 3, 4, and 5; all five active reservoirs; and at the Highland Drive transfer station.

The telemetry system indicates reservoir levels, provides high and low level alarms and level recording; automatic well starting and stopping, transfer station flow control and data recording of the status of the various system components.

**WATER RIGHTS**

The City currently has municipal water rights issued by the Washington State Department of Ecology for an instantaneous withdrawal of 2,520 gpm and 1,629.3 acre-feet annually. Excluding the Watercress Springs right which is temporarily out of service, these amounts are reduced to an instantaneous withdrawal of 2,220 gpm and 1,145.3 acre-feet annually. Although the City is not currently using water from Watercress Springs, it does not intend to abandon this water right.

## GROUND WATER RIGHTS

**Ground Water Certificate (GWC) No. 5327:** 650 gpm, 700 ac-ft per year, Well No. 3. The annual portion withdrawn under this water right certificate and GWC 265-C (relinquished), GWC 266-D, GWC 369-A, GWC 3410-A and SWC 592 (relinquished) is not to exceed 700 ac-ft/yr. The instantaneous quantity, 650 gpm, issued as additive.

**GWC No. 266-D:** 100 gpm, 29 ac-ft annually, Well No. 1. This certificate was initially withdrawn from a 25 ft deep, dug well located in Alma Park. The rights were transferred to be withdrawn from Well No. 1, located approximately 50 ft west of the Alma Park Well. The period of use is restricted to April 1 through October 31 each year as the use was originally for only park and swimming pool uses. The instantaneous quantity, 100 gpm, is additive. The annual quantity, 29 ac-ft/yr is non-additive (see GWC 5327).

**GWC No. 369-A:** 350 gpm, 200 ac-ft annually, Well No. 5. The instantaneous quantity, 350 gpm, is additive. The annual quantity, 200 ac-ft/yr is non-additive (see GWC 5327). This certificate initially authorized the City to withdraw 500 gpm, 200 ac-ft annually for municipal supply. However, on 8/23/1988, in a decision by the Department of Ecology, the withdrawal rate was reduced to 350 gpm as a condition of transferring this right from Well No. 1 to Well No. 3. Although the City did not appeal Ecology's decision, there remains a question as to whether this reduction was justified considering that this is a municipal water right.

**GWC No. 3410-A:** 200 gpm, 320 ac-ft annually, Well No. 2. This certificate was issued supplemental to certificates SWC 592 (relinquished), GWC 265 (relinquished), GWC 266-D and GWC 369; consequently, the annual quantity is non-additive. The instantaneous quantity, 200 gpm, is additive.

**CG-4-23854C:** 550 gpm, 400 ac-ft per year, Well No. 4. Both quantities are additive. The City filed for and received temporary authorization to transfer 300 gpm of these rights to Well No. 5 for one year, from August 7, 2006 to August 1, 2007 while the City completed its arsenic treatment plant project for Well No. 4.

**GWC No. G4-29193:** 300 gpm, 400 ac-ft annually, Well No. 5. The annual quantity of this water right issued non-additive to certificates GWC 266-D, GWC 369-D, GWC 3410-A, GWC 5327-A and G4-23854C and Water Right Claim No. 000052 (should a right be confirmed following adjudication). No water is allowed to be withdrawn under this authorization when the Okanogan River is below the minimum flows identified in the authorization. The instantaneous quantity was reduced from 650 gpm to 300 gpm when GWC No. 369-A was transferred to Well No. 5.

**GWC No. G4-3838-A:** 50 gpm, 39 ac-ft, Well No. 3. This certificate is being transferred from the Progressive Flats Water Association (PFWA) wells to City of Okanogan's Well No. 3. Both instantaneous and annual rights are additive.

**GWC No. G4-30573-A:** 20 gpm, 6.3 ac-ft, Well No. 3. This certificate is being transferred from the PFWA wells to City of Okanogan's Well No. 3. Both instantaneous and annual rights are additive.

**SWR Certificate 592:** Around 1930, the City completed a well about 500 feet from the bank of the Okanogan River at about 1<sup>st</sup> and Queen Streets to supplement the City's sole supply of water at the time, the Shull Springs supply on Salmon Creek. According to the remarks on the permit application, the City applied for the permit in 1931, one or two years after completing the well. A certificate was issued in 1932 for 1.5 cfs (about 670 gpm). The City voluntarily relinquished the right in 1970.

## **WATER RIGHT CLAIMS**

**Surface Water Right (SWR) Claim 000052:** This source is commonly referred to as "Watercress Springs", "Shull Springs", or simply "The Springs". On February 24, 1970, the City filed a water right claim for this source, listing the date of first of use to be 1908, in the amounts of 300 gpm and 484 ac-ft per year. It has been reported that the spring flow currently varies from 175 gpm to 300 gpm. The water rights consist of certificates and claims and are summarized in Table 1-5. Copies of the City's water rights are presented in Appendix K.



**TABLE 1-5**  
**Water Rights Summary**

<b>Well No.</b>	<b>Certificate</b>	<b>Control Number</b>	<b>Priority Date</b>	<b>Qi <sup>(2)</sup> (gpm)</b>	<b>Qa <sup>(2)</sup> (ac-ft/yr)</b>
Well No. 1	Certificate	GWC No. 266-D	1924	100 <sup>(A)</sup>	29 <sup>(N)(1)</sup>
Well No. 2	Certificate	GWC No. 3410-A	2/21/48	200 <sup>(A)</sup>	320 <sup>(N)(2)</sup>
Well No. 3	Certificate	GWC No. 5327	9/13/63	650 <sup>(A)</sup>	700 <sup>(3)</sup>
	Certificate	GWC No. G4-3838-A	6/7/06	50 <sup>(A)(4)</sup>	39 <sup>(A)</sup>
	Certificate	GWC No. G4-30573-A	1/22/91	20 <sup>(A)(4)</sup>	6.3 <sup>(A)</sup>
Well No. 4	Certificate	CG4-23854C	12/24/75	550 <sup>(5)(A)</sup>	400 <sup>(A)</sup>
Well No. 5	Certificate	GWC No. 369-A	7/27/46	350 <sup>(A)</sup>	200 <sup>(N)(6)</sup>
	Certificate	GWC No. G4-29193	1/30/87	300 <sup>(A)(S)</sup>	400 <sup>(N)(7)</sup>
Watercress Springs	Claim	SWR No. 000052	1908	300 <sup>(N)</sup>	484 <sup>(A)</sup>
<b>Total</b>				<b>2,520</b>	<b>1,629.3</b>

- (1) This right was originally held under Certificate 266D for the hand-dug Park Well and was transferred to Well No. 1 on 7/20/87.
- (2) The Record of Examination on this right states that at the time this certificate was issued, the City held SW Certificate 592 and GW Certificates 265, 266, and 369A for a total of 1675 gpm and 1488 A-ft. The 320 ac-ft annual portion of this right was issued non-additive to these rights. SW Certificate 592 was subsequently relinquished.
- (3) This certificate was issued non-additive to SW Certificate 592 and GW Certificates 265, 266, 369A, and 3410. The total withdrawal allowed under all of these certificates was limited to 700 ac-ft/yr.
- (4) The City has filed water right change applications CG4-GWC3838-A & CG4-30573P to allow withdrawal from Well No. 3.
- (5) The City received temporary authorization to transfer 300 gpm of these rights to Well No. 5 for one year, from 8/7/06 while the City completed its arsenic treatment plant project for Well No. 4.
- (6) This right was originally held under Certificate 369-A for Well No. 1 and was transferred to Well No. 5 on 7/20/87. This certificate is included in the 700 ac-ft/yr cap identified in the 1963 Well No. 3 certificate.
- (7) The annual portion of the certificate was issued non-additive to the City's Ground Water Certificates No. 266-D, No. 369-D, No. 3410-A, and No. 5327-A, No. G4-23854C and Water Right Claim No. 000052. The instantaneous portion of the certificate was also issued non-additive subject to minimum Okanogan River flows and Certificate of Change 369-A. The City issued the Proof of Appropriation in 1988. The DOE wrote in a subsequent correspondence that a certificate for this well would be issued following a final DOE inspection.  
 (A) Additive.  
 (N) Non-additive.  
 (S) Subject to minimum Okanogan River flows (see Appendix K).

## **PROGRESSIVE FLATS WATER RIGHTS**

On January 27, 2006, the Progressive Flats Water Association (PFWA) filed applications for change CG4-GWC3838-A and CG4-30573P to add the Okanogan Well No. 3 as a point of withdrawal for the PFWA water rights. The PFWA has wells which have been phased out of use now that they use water wholesaled by the City of Okanogan via the pipeline and booster station constructed in the late 2000s. The water table at the Progressive Flats well sites had been dropping and the PFWA wells had begun to have low production rates in addition to hazardous uranium content.

## **DICKSON WATER RIGHT**

The City also holds irrigation rights for two shallow wells and the Okanogan River for a system that is not currently connected to the City's municipal water system. This water right is based on an older water right held by Mr. Warren Dickson.

The original water right held by Mr. Dickson was a 390 gpm and 156 acre-foot/year surface water right diverted from the Okanogan River for irrigation purposes from April 1 to August 15. The right has been determined to be a tribal reserved right by the Pollution Control Hearings Board (PCHB). The decision was prompted by issuance of a water right permit by DOE in 1979 as requested by Mr. Dickson. In 1993, the DOE issued a superceding certificate following the PCHB decision, with the provision that if the tribal reserved right is upheld through adjudication, the certificate will be relinquished. However, if the tribal reserved right is not upheld, the certificate shall provide the holder with an interruptible right to the same quantity subject to minimum Okanogan River flows.

In 1998, the City entered into an agreement with Mr. Dickson acquiring a parcel and its associated water right on the Colville Nation east of the Okanogan River and within City limits. The agreement transferred to the City the ownership of the parcel and a portion of the water right appurtenant to the land – specifically, 24/40ths of the original water right.

Based on the 1998 agreement and subsequent review by the Tribal Water Committee in 2000, the City is entitled to 0.544 cfs (or 245 gpm) and 85 acre-feet, subject to minimum Okanogan River flows. The City has relinquished the Dickson water right in exchange for a permit from the Colville Tribe for 0.544 cfs and 85 acre-feet. This water has historically been diverted from two shallow wells on the City property and also directly from the Okanogan River. None of these facilities are currently connected to the City's potable water system. The tribal Water Committee has restricted the use of water under this water right to on-site use only. The City currently operates and maintains the facilities for irrigation of a sports field at a shared cost with the owners of the remainder of the original property.

## **IRRIGATION SUPPLY**

The City is also partially served by the Alta Vista Irrigation District and the Okanogan Irrigation District. Approximately 290 parcels (less than 10 percent of the area within the City Limits) of the City are served by irrigation water. The Okanogan Irrigation District serves approximately 51 parcels and the Alta Vista Irrigation District serves approximately 239 parcels. A schematic of those connections served within the City Limits is shown on Figure 1-3. The City does not operate or maintain these irrigation facilities.

## **PLANNING AND POLICIES**

The following sections describe the City's current water system planning efforts and water service policies.

## **RELATED PLANNING DOCUMENTS**

The following planning documents were used in the preparation of the City of Okanogan 2015 Water System Plan Update:

- City of Okanogan, Water System Plan Update, Gray & Osborne, Inc., October, 2009.
- City of Okanogan, Comprehensive Plan, 2015.
- Okanogan County, Comprehensive Plan, 2014.

## **WATERSHED PLANNING**

Concerning endangered and threatened species listed in the area, the Okanogan River is tributary to the Upper Columbia River. The Upper Columbia River spring-run Chinook salmon were listed as Endangered in 1994, critical habitat was established in September 2005; Upper Columbia River steelhead were listed as Endangered in June 2007 and critical habitat was established in September 2005; Columbia River Chum Salmon were listed as Threatened in June 2005, critical habitat was designated in September 2005; Columbia River bull trout were listed as Threatened in 1998 and the latest critical habitat determination was in September 2005.

The City of Okanogan is located in Water Resource Inventory Area (WRIA) 49, which is in Phase 2 & 3 of implementation. The Department of Ecology lists the status of Watershed Planning Act Activities in WRIA 49 as "Currently working on Phase 2: Watershed Assessment and Phase 3: Plan Development at the same time" in regards to RCW 90.82 Watershed Planning.

## **SERVICE AREA CHARACTERISTICS**

### **EXISTING AND FUTURE SERVICE AREA**

The City of Okanogan's existing service area, retail service area, future service area and service area are shown on Figure 1-3. The City's existing service area encompasses the City Limits except those portions not currently served by the City as shown on Figure 1-3. The City's water rights place of use is defined as the area within the service area in accordance with WAC 246-290-107. The City's retail and future service areas are coincident with the City Limits.

The City wholesales water to the Progressive Flats Water Association. On November 14, 2006, the City of Okanogan signed an agreement with the Progressive Flats Water Association for the delivery of water for domestic use for the Progressive Flats service area in exchange for the temporary transfer of all of the Progressive Flats water rights to the City. The City's service area, which encompasses the Urban Growth Area (UGA) PFWA boundaries, is also shown on Figure 1-3. The portion of the City east of the river is located within the Colville Confederated Tribes Reservation.

### **ZONING**

Extensive zoning changes are not expected to the area in and around the City within the next 20 years. Residential development is expected to continue at the system extremities, with commercial and industrial growth centered on the railroad corridor and the major traffic route through the City.

### **NEIGHBORING WATER PURVEYORS**

According to the Department of Health, the City has nine neighboring water purveyors:

- City of Omak (Group A Water System ID 63750)
- Progressive Flats Water Association (Group A Water System ID 69650)
- Okanogan County Fair (Group A Water System ID 34314)
- Our Lady of Valley Catholic Church (Group A Water System ID 41522)
- Way S (Group A Water System ID 27676)
- Don's Mobile Home Court (Group B Water System ID 47840)
- Okanogan Maintenance Facility (Group B Water System ID HD011)
- Deering Water System (Group B Water System ID 00823)
- Hidden City Mobile Home (Group B Water System ID 32623)

The City of Okanogan has no water service agreements with any other water purveyors besides the Progressive Flats Water Association at this time.

## **DUTY TO SERVE**

Per RCW 43.20.260, the City has a duty to serve within its retail service area if a potential user approaches the City with a request for connection and the following threshold factors apply:

- The City has sufficient capacity to serve water in a safe and reliable manner.
- The service request is consistent with adopted local plans and development regulations.
- The City has sufficient water rights to provide service.
- The City can provide service in a timely and reasonable manner.

City resolution No. 2006-19, included in Appendix N, addresses water utility connections outside the Okanogan City Limits and the City maintains a policy of not providing water service connections to properties outside the City Limits, except in the case of certain conditions as detailed in the resolution.

## **SERVICE AREA POLICIES AND CONDITIONS OF SERVICE**







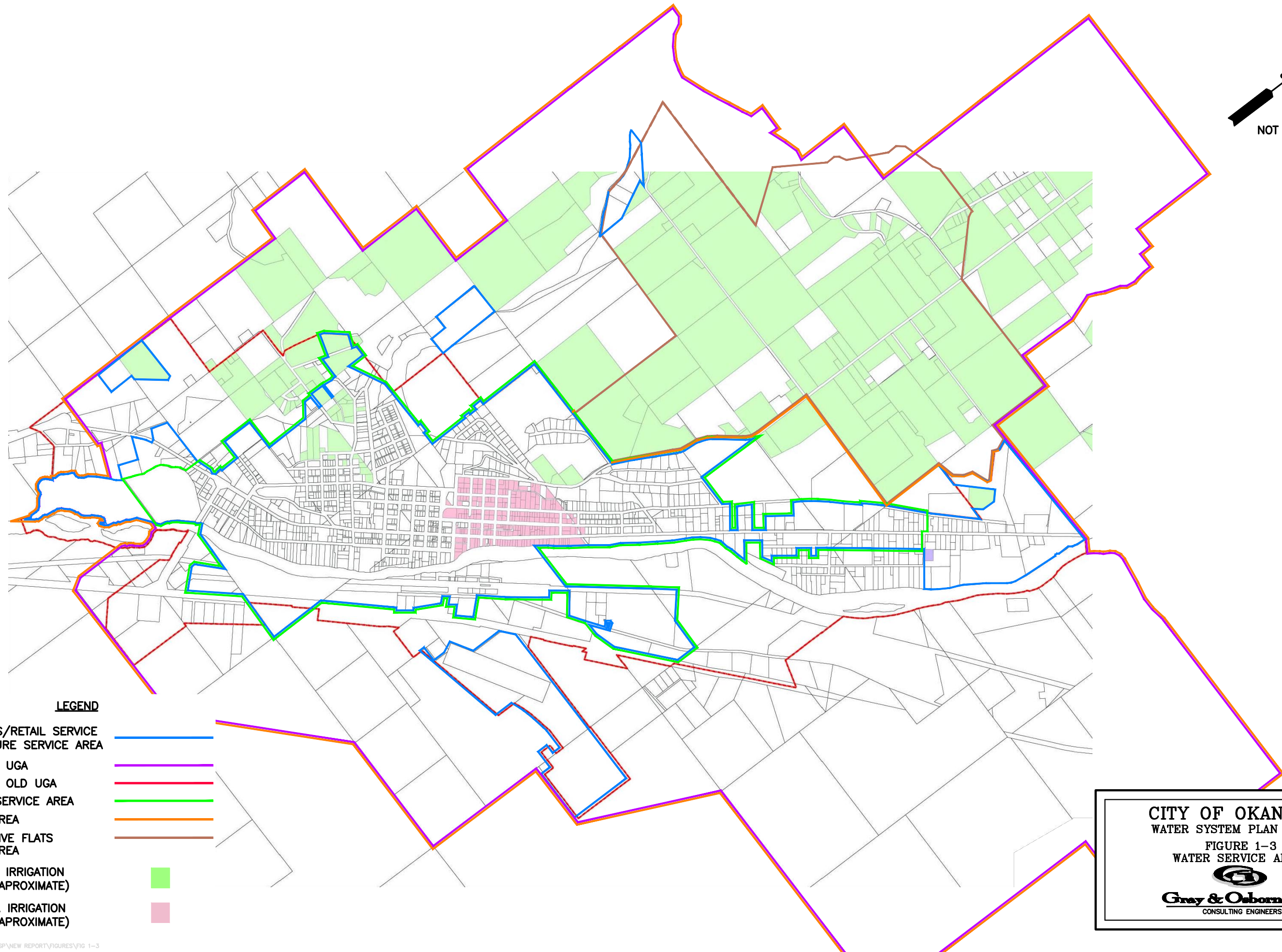
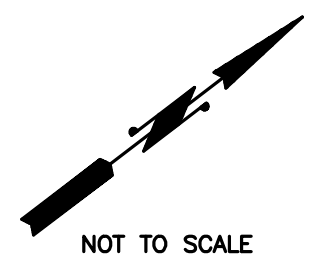

Service area policies are addressed in the City's ordinances. These ordinances have been developed to be consistent with the City's Comprehensive Plan and with the City's development standards.

Connection to a City water main is discussed in Okanogan Municipal Code (OMC) Title 13, anyone desiring service can apply at City Hall.

The Washington State Department of Health has established a list of service area policies to be referenced in water system planning documents. Table 1-6 lists the type of service area policy, current City policies, and the reference source.



**LEGEND**

- CITY LIMITS/RETAIL SERVICE AREA/FUTURE SERVICE AREA 
- OKANOGAN UGA 
- OKANOGAN OLD UGA 
- EXISTING SERVICE AREA 
- SERVICE AREA 
- PROGRESSIVE FLATS SERVICE AREA 
- OKANOGAN IRRIGATION DISTRICT (APPROXIMATE) 
- ALTA VISTA IRRIGATION DISTRICT (APPROXIMATE) 

**CITY OF OKANOGAN**  
WATER SYSTEM PLAN UPDATE  
FIGURE 1-3  
WATER SERVICE AREAS



**Gray & Osborne, Inc.**  
CONSULTING ENGINEERS



**LEGEND**

- CITY LIMITS
- - - URBAN GROWTH AREA
- - - PROGRESSIVE FLATS WATER ASSOCIATION BOUNDARY
- R-1      ■ I-1
- R-2      ■ I-2
- R-3      ■ AIRPORT
- R-4      ■ R-R
- C-1      ■ CONSERVANCY
- C-2      ■ TRIBAL: OUT OF CITY LIMITS
- C-3      □ MINIMUM REQUIREMENT DISTRICT

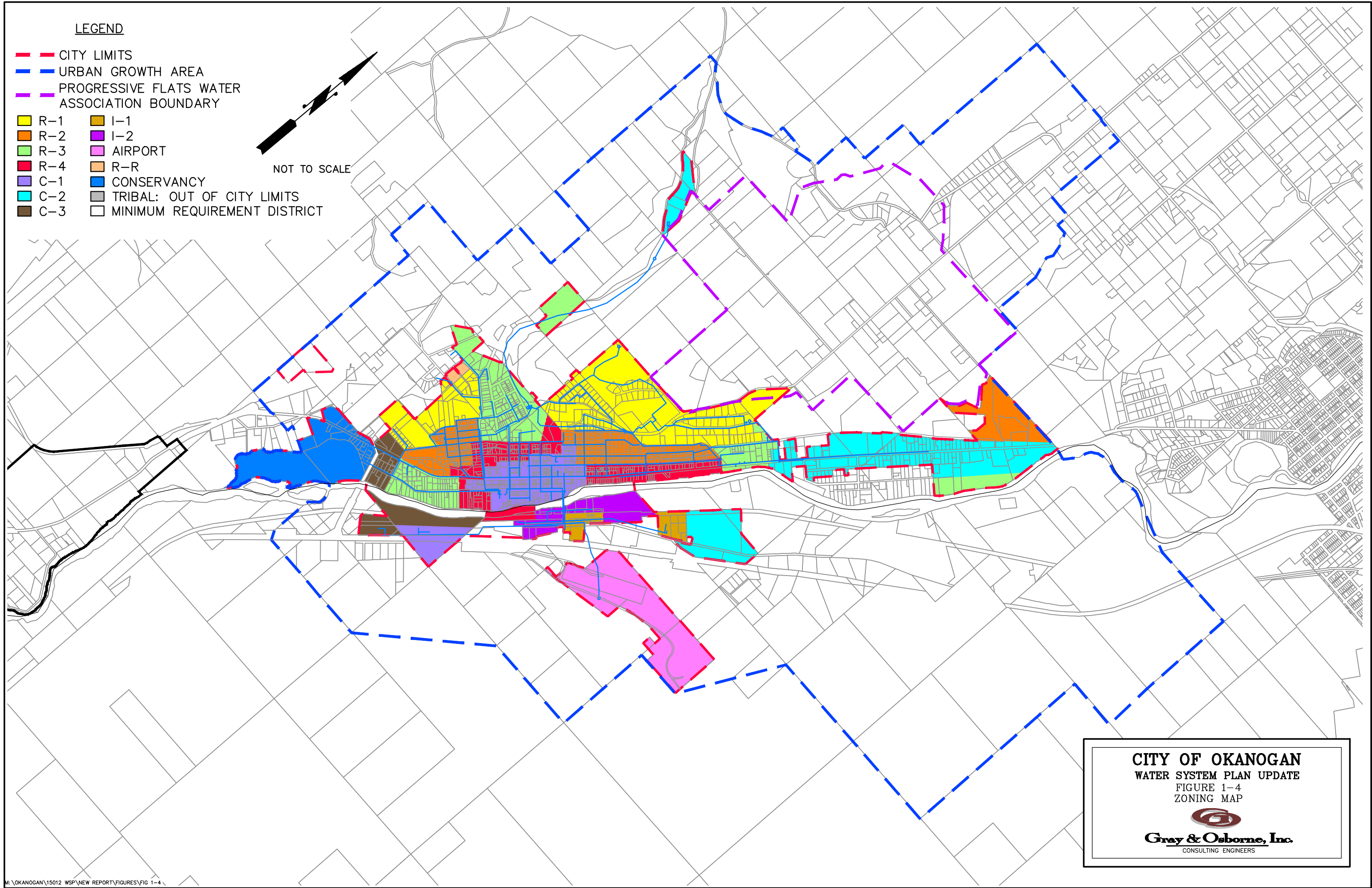
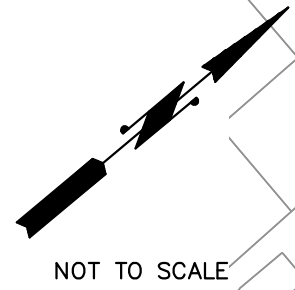

**CITY OF OKANOGAN**  
WATER SYSTEM PLAN UPDATE  
FIGURE 1-4  
ZONING MAP

**Gray & Osborne, Inc.**  
CONSULTING ENGINEERS

**TABLE 1-6**

**Service Area Policies**

<b>Policy Name</b>	<b>Description</b>	<b>Reference</b>
Wholesaling of Water	Wholesaling or wheeling permitted.	Not covered <sup>(1)</sup>
Annexations	Annexation required to obtain water service.	Resolution No. 2006-19
Design Performance Standards	Defines minimum standards for construction of domestic water facilities.	See Chapter 7
Mandatory Connection	Connection to water system within corporate limits is mandatory.	Not covered
Plat Review Fees	Developer responsible for all plat review fees.	OMC Title 17
Latecomer Agreements	Agreements allowing cost reimbursement when “latecomers” hook up.	Case-by-case approval
Oversizing	City provides funds for upsizing developer extensions for future growth.	Case by case approval
Cross-Connection Control Program	Policy establishing the requirements for cross connection prevention devices.	OMC 13.10
System Extensions	Policy regarding service extensions.	OMC 13.04
Design and Performance Policy	Policy establishing design and construction standards in accordance with the City’s standards for all connections and extensions.	OMC 13.04 and OMC 17.28
Connection Responsibility Policy	Policy stating whether connection responsibility shall be completed by the water system or by a hired professional at the expense of the applicant.	OMC 13.04.440
Connection Fee Policy	An established connection fee required to be paid in full before connection to the system.	Ordinance 1098
Meter Policy	Policy stating whether or not an individual service meter is required.	OMC 13.04.310

(1) The City’s written policy is to not serve outside its corporate limits unless certain conditions are met. For these conditions see Resolution No. 2006-19 (Appendix N). The City does not expect to begin doing so within the 6-year planning period.



## CHAPTER 2

### BASIC PLANNING DATA

This chapter presents the basic planning data used to estimate Okanogan’s future water demands. Water demand projections are used in Chapter 3 to evaluate the adequacy of the City’s existing water system.

#### HISTORICAL DATA

This section contains historical population, services, and production/consumption data.

#### HISTORICAL POPULATION

Population within Okanogan has increased steadily as shown on Figure 2-1.

FIGURE 2-1

#### Historical Population

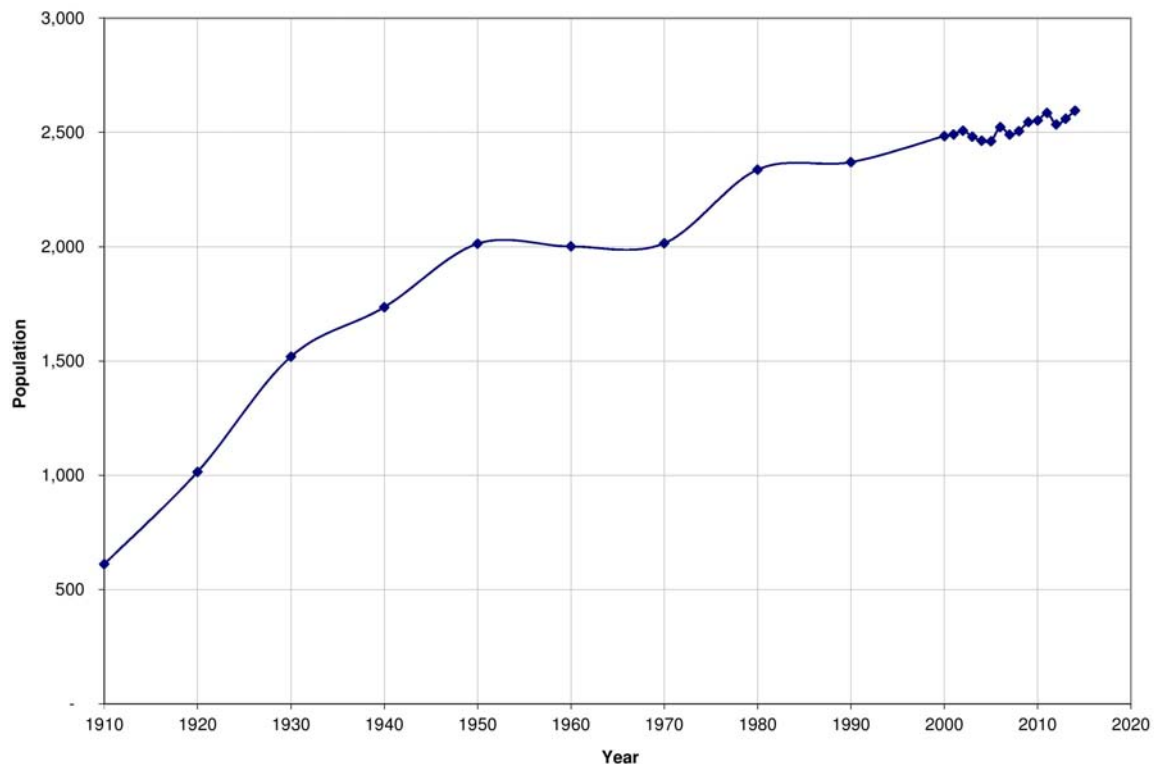

- (1) Source: City of Okanogan Comprehensive Plan and Engineering Report (1996).
- (2) Source: Office of Financial Management, Forecasting Division, Postcensal Estimates of April 1<sup>st</sup> Population and Housing, 1960-Present.
- (3) Note that the population of the Progressive Flats Water Association (approximately 135 in 2014) is not shown on this figure.

## SERVICE CONNECTIONS

Table 2-1 lists the number of connections in each of the City’s main customer categories for 2014.

**TABLE 2-1**  
**2014 Customer Accounts**

Customer Classification	Number of Connections <sup>(1)</sup>	Percent of Connections
Residential - Single Family	725	73.9%
Residential - Multi Family <sup>(2)</sup>	56	5.7%
Rural	31	3.2%
Commercial <sup>(3)</sup>	143	14.6%
Schools	10	1%
City <sup>(4)</sup>	16	1.6%
<b>Total</b>	<b>981</b>	<b>100%</b>

- (1) Approximate - count may vary during the year.
- (2) These connections may serve multiple units with the same connection. The City estimates that there are approximately 205 units included in this classification.
- (3) These connections may serve multiple units with the same connection. The City estimates that there are approximately 160 units included in this classification.
- (4) Includes City Hall, cemetery, parks and other City facilities.

## HISTORICAL WATER USE

Water production is metered as it enters the distribution system at each of the well sites. This production data is recorded via the telemetry system on a daily basis. Water consumption is metered at individual service water meters. Consumption data is recorded on a monthly basis, typically April through October, except for the high use commercial meters which are read each month of the year. During the winter months, weather conditions make meter reading difficult, so the base rate is typically billed, and any overage is addressed once the meters are again read in the spring. The City is in the process of installing radio-read meters that will enable the City to read meters through the winter months. The City has installed mag-meters on Wells No. 2, 3, 4 and 5 which will facilitate more accurate metering of water production.

## AVERAGE DAY DEMAND (ADD)

Table 2-2 lists water production between 2006 and 2014. Annual production, or demand, is commonly reduced to a daily value, and is referred to as the average day demand (ADD). The ADD in 2007 was higher than the more recent years of 2012-2014 where ADD has decreased significantly. The 4-year average ADD for years 2011-2014 will be used for analysis in this Plan.

**TABLE 2-2**  
**2006-2014 Average Daily Demand (ADD)**

<b>Year</b>	<b>Service Area Population<sup>(1)(2)</sup></b>	<b>Total Annual Production (gal)</b>	<b>ADD (gpd)</b>	<b>ADD (ac-ft/yr)</b>
2006	2,485	217,330,000	595,000	670
2007	2,445	226,471,000	620,000	700
2008	2,470	207,528,000	569,000	640
2009	2,495	217,486,000	596,000	670
2010	2,552	184,237,000	505,000	570
2011	2,585	197,726,000	542,000	610
2012	2,535	222,626,000	610,000	680
2013	2,560	208,481,000	571,000	640
2014	2,595	169,170,000	463,000	520
<b>4-Year Average<sup>(3)</sup></b>			<b>547,000</b>	<b>610</b>

(1) Source: OFM, Forecasting Division, Intercensal Population Estimates (2000-2010).

(2) Source: OFM, Forecasting Division, Postcensal Population Estimates (2010-2014).

(3) 4-year average based on data from 2011 through 2014.

The monthly distribution of production is shown on Figure 2-2 for 2009-2014. Typical of most eastern Washington communities without separate irrigation, demands increase significantly in the summer as the result of lawn irrigation. Water used for irrigation is largely supplied by the City’s potable system, however, there are approximately 290 parcels served by the local irrigation districts through separate, non-metered irrigation systems.

Monthly water production from 2009-2014 is shown on Figure 2-2. In general, peak month water production has decreased approximately 20 percent over the past 5 years.

**FIGURE 2-2**

**2009-2014 Monthly Water Production**

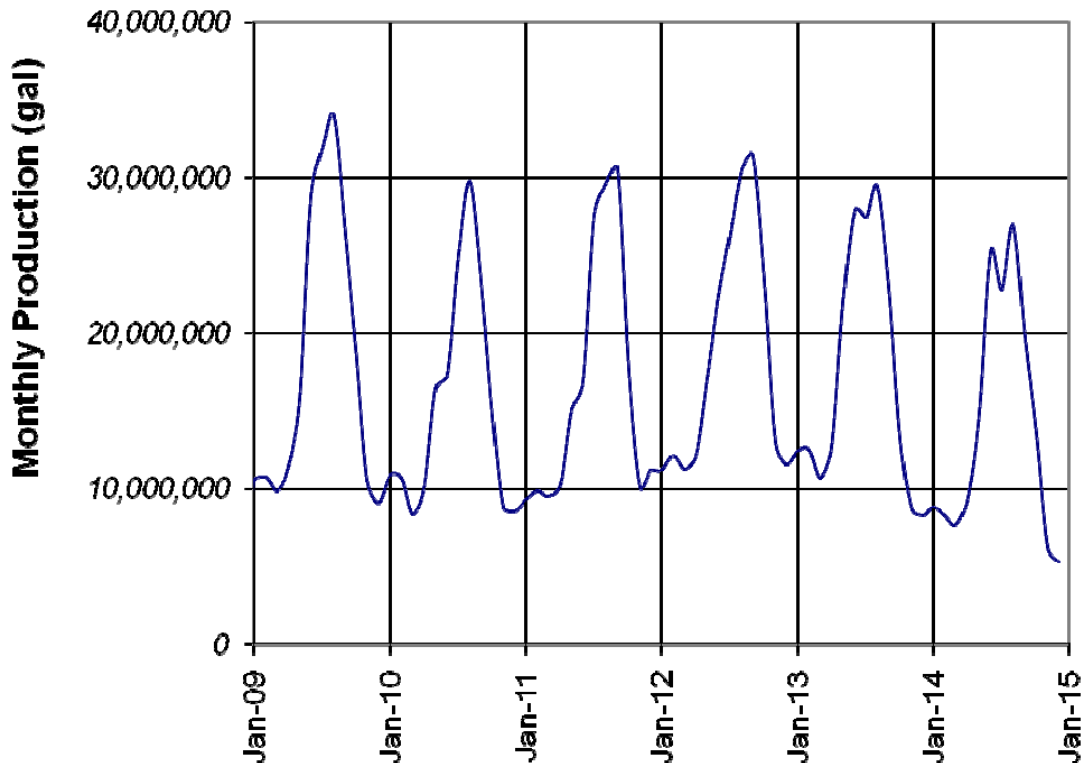
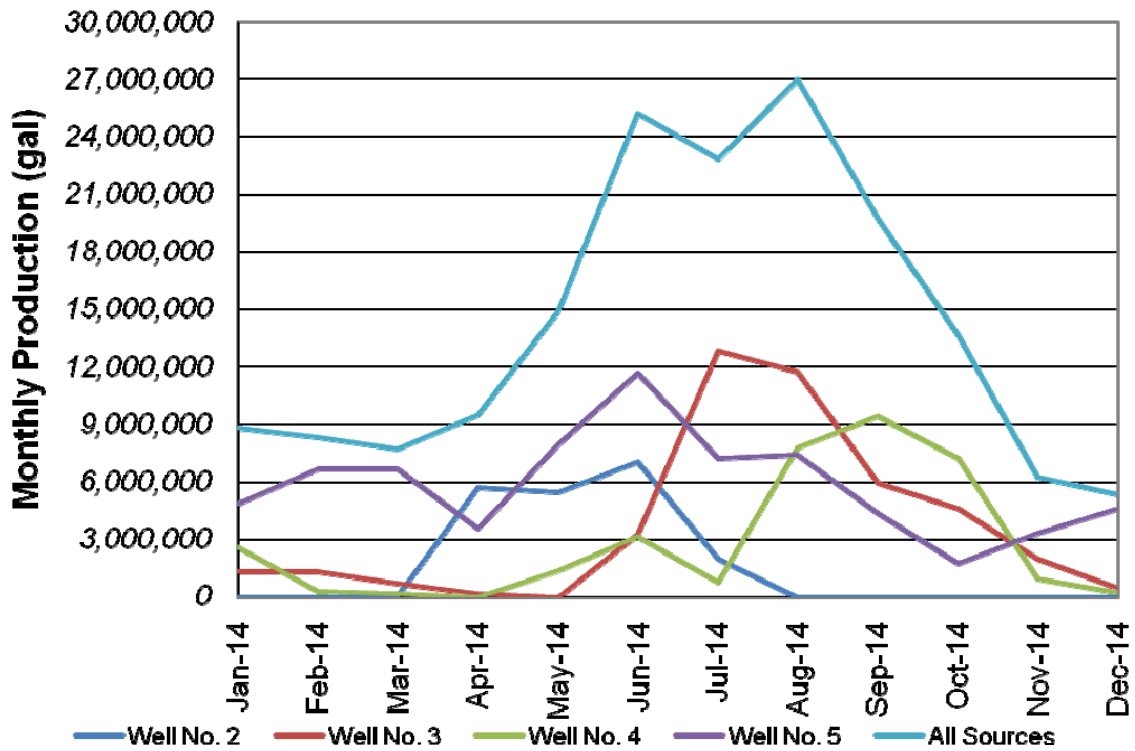

Figure 2-3 shows monthly production for each well and all wells combined for 2014.

**FIGURE 2-3**

**2014 Monthly Water Production By Well**



**MAXIMUM DAY DEMAND (MDD)**

The maximum day demand (MDD) is determined by the previous four year’s production records. The MDD is defined as the maximum quantity of water produced in a 24-hour period. Table 2-3 shows the history of the MDD, taken from the daily source meter reading data for 2009 through 2014. The ratio of MDD to ADD shown in this table represents the maximum day demand peaking factor used for system analysis throughout this Plan.

**TABLE 2-3**

**2009-2014 Maximum Day Demand (MDD)**

<b>Year</b>	<b>ADD <sup>(1)</sup> (gpd)</b>	<b>MDD (gpd)</b>	<b>MDD <sup>(2)</sup> (gpm)</b>	<b>MDD/ADD Ratio</b>
2009	596,000	1,190,000	826	2.0
2010	505,000	1,116,000	775	2.2
2011	542,000	1,101,000	765	2.0
2012	610,000	1,121,000	778	1.8
2013	571,000	1,374,000	954	2.4
2014	463,000	1,251,000	869	2.7
<b>4-Year Average<sup>(3)</sup></b>	<b>547,000</b>	<b>1,212,000</b>	<b>842</b>	<b>2.2</b>

(1) From Table 2-2.

(2)  $MDD(gpm) = MDD(gpd) \div 1440 \text{ gpm/gpd}$ .

(3) 4-year average based on data from 2011 through 2014; ADD and MDD figures rounded up to the nearest 1,000 gpd.

MDD/ADD ratios for the City range from a low of 1.8 in 2012 to a high of 2.7 in 2014. The Washington State Department of Health Water System Design Manual cites typical peaking factors between 1.5 and 3.0. The Okanogan Water System Plan Update (2009) used a maximum day demand peaking factor of 2.1. The 4-year average ratio of 2.2 as indicated in Table 2-3 will be used in the calculation of the peaking factor for this report.

**PEAK HOUR DEMAND (PHD)**

The maximum quantity of water used in a one-hour period during a maximum day is the peak hour demand (PHD). For the year 2014, the PHD/ADD ratio was 3.9. To determine the peaking factor, we took the PHD/ADD ratio and divided it by the MDD/ADD ratio from above (of 2.2), this gives us a peaking factor of 1.8. The Okanogan Water System Plan Update (2009) utilized a peaking factor of 1.8. It is generally accepted that this peak hour peaking factor ranges from 1.5 to 2.5. The Department of Health’s Water System Design Manual (WSDM) also provides a method for determining the City’s peaking factor. This method takes into account the number of service connections, the MDD, empirical factors and coefficients in order to arrive at a suitable factor. The WSDM determined peaking factor (PHD/MDD ratio) is 1.7. The calculated peaking factor of 1.8 will be used for this Plan.

**CONSUMPTION HISTORY**

As noted above, the City reads service meters monthly from April to October and only reads the high use commercial meters year round. In April, the City begins reading all meters again and charges its customers for any overage incurred during the winter months. Table 2-4 shows the annual water consumption broken out into the City’s various customer classifications.

**TABLE 2-4**

**2010-2014 Total Water Consumption**

Year	Resid. SF <sup>(1)</sup> (gal)	PFWA <sup>(2)</sup> (gal)	Resid. MF <sup>(1)</sup> (gal)	Rural (gal)	Commer. (gal)	Schools (gal)	City (gal)	Total (gal)
2010	75,533,000	295,000	19,360,000	5,644,000	34,587,000	15,203,000	24,889,000	175,511,000
2011	73,132,000	3,473,000	20,696,000	5,605,000	37,573,000	13,195,000	24,261,000	177,935,000
2012	78,583,000	4,072,000	21,657,000	6,042,000	36,552,000	16,966,000	25,169,000	189,041,000
2013	74,042,000	3,723,000	19,671,000	6,040,000	33,919,000	19,275,000	25,082,000	181,752,000
2014	71,350,000	4,207,000	16,247,000	4,373,000	25,853,000	18,763,000	21,401,000	162,194,000
<b>4-Year Avg. <sup>(3)</sup></b>	<b>74,277,000</b>	<b>3,869,000</b>	<b>19,568,000</b>	<b>5,515,000</b>	<b>33,474,000</b>	<b>17,050,000</b>	<b>23,978,000</b>	

- (1) SF = Single Family, MF = Multi-Family.
- (2) PFWA = Progressive Flats Water Association.
- (3) 4-year average based on data from 2011 through 2014, rounded to the nearest 1,000 gallons.

Residential consumption, consisting of single family, multi-family, and PFWA consumption, is summarized in Table 2-5 for 2010 to 2014. The average residential per capita consumption is not excessive considering that this amount includes irrigation for the majority of service connections. As shown in Table 2-5, the average per capita daily residential consumption is 104 gallons per capita day (gpcd).

**TABLE 2-5**

**2010-2014 Residential Water Consumption**

Year	Service Area Population	Residential Consumption <sup>(1)</sup> (gal/yr)	Avg. Day Res. Consumption <sup>(2)</sup> (gpd)	Per Capita Res. Consumption <sup>(3)</sup> (gpcd)
2010	2,552	95,188,000	261,000	102
2011	2,585	97,301,000	267,000	103
2012	2,535	104,312,000	286,000	113
2013	2,560	97,436,000	267,000	104
2014	2,595	91,804,000	252,000	97
<b>4-Year Average<sup>(4)</sup></b>				<b>104</b>

- (1) Residential SF plus Residential MF plus PFWA from Table 2-4.
- (2) Average Day Residential Consumption = (Annual Residential Consumption) / (365 days) and rounded to the nearest 1,000 gpd.
- (3) Per Capita Residential Consumption = (Average Day Residential Consumption) / (Service Area Population). gpcd = gallons per capita per day.
- (4) 4-year average based on data from 2011 through 2014.

**Seasonal Variations in Consumption**

The City’s 2014 monthly water use by classification is shown on Figure 2-4. As can be seen in the figure, many of the classification usages vary significantly depending upon



the season of the year, with irrigation demands playing a significant role in water consumption during the summer months for residential, irrigation, and apartment customer classifications.

**FIGURE 2-4**

**2014 Seasonal Variations in Consumption by Customer Classification**

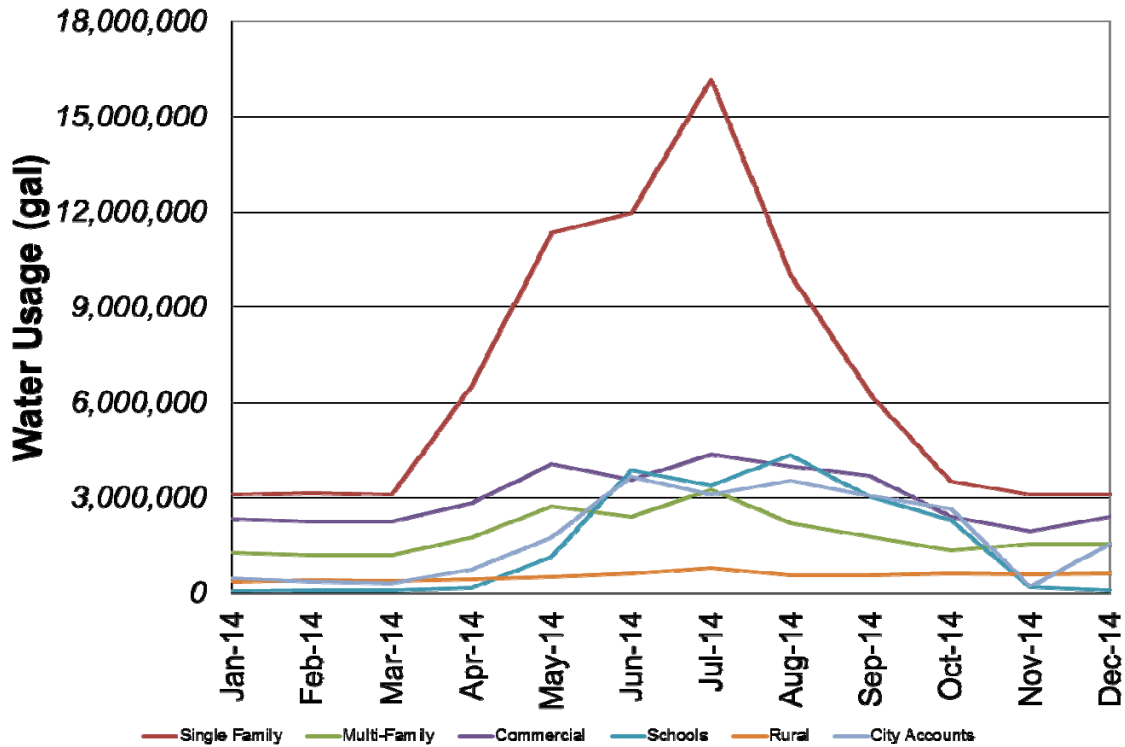

**DISTRIBUTION SYSTEM LEAKAGE**

Distribution system leakage (DSL) is defined as the difference between total water produced and authorized consumption. DSL includes any water loss due to leaks or unauthorized uses such as illegal service connections. DSL also includes accounting errors, inaccurate source and customer meters and storage tank overflows. Water leaving the system for un-metered usage such as flushing of mains and fire flows, if accounted for, is counted as an authorized use of water. Table 2-6 shows the calculation of DSL for the years 2010 to 2014.

The Washington State Legislature passed the Municipal Water Supply – Efficiency Requirements Act of 2003, better known as the Municipal Water Law. This law presents municipal water suppliers with certain obligations to comply with, one of which is to meet a “Distribution System Leakage Standard” of 10 percent or less by July 1, 2011 (see DOH Water Use Efficiency Guidebook) or three years after installing all service meters. The City is pursuing efficient use of water resources and seeking to reduce DSL in order to meet this new standard.

The criteria for meeting the distribution leakage standard is based upon the DSL rolling average based on the most recent 3 years. For the City of Okanogan, the most recent 3-year average (from the years 2012 through 2014) is shown in Table 2-6 to be just over 10 percent.

**TABLE 2-6  
2010-2014 Distribution System Leakage**

<b>Year</b>	<b>Annual Production<sup>(1)</sup> (gal)</b>	<b>Annual Consumption<sup>(1)</sup> (gal)</b>	<b>Distribution System Leakage<sup>(2)</sup> (gal)</b>	<b>Percent of Total Production<sup>(3)</sup> (%)</b>	<b>3-Year Average (%)</b>
2010	184,237,000	176,887,000	7,350,000	4%	
2011	197,726,000	178,730,000	18,996,000	10%	6.5%
2012	222,626,000	189,710,000	32,916,000	15%	9.5%
2013	208,481,000	182,421,000	26,060,000	12%	12.3%
2014	169,170,000	162,712,000	6,458,000	4%	10.4%

- (1) Annual production and consumption from City records; consumption data includes estimated fire department usage (authorized water use).
- (2) Distribution System Leakage = (Annual Production) – (Annual Consumption).
- (3) Percent of Total Production = (Distribution System Leakage) ÷ (Annual Production).

The City has metered all connections to the water system. The City meters water used at its parks, the City Library and City Hall complex, Wastewater Treatment Facility and the City’s pool.

**EQUIVALENT RESIDENTIAL UNITS**

The use of Equivalent Residential Units (ERUs) is a way to express water use by non-residential customers as an equivalent number of residential customers. ERUs are calculated by dividing the total volume of water utilized in the single-family customer class by the total number of single-family residential connections. This number defines the average residential water use. The volume of water used by the other customer classes can then be divided by the average residential use to determine the equivalent residential units utilized by the other customer classes. The ERUs for each customer class are shown in Table 2-7. The average daily single-family residential consumption for the City of Okanogan was determined to be 270 gallons/day/ERU {71,350,000 gal/yr ÷ 365 days/yr ÷ 725 residential connections = 270 gallons/day/ERU}.

**TABLE 2-7**

**2014 Equivalent Residential Units**

<b>Classification</b>	<b>Annual Consumption<sup>(1)</sup> (gal)</b>	<b>Number of Connections<sup>(2)</sup></b>	<b>ERUs<sup>(3)</sup></b>	<b>ERUs/ Conn.</b>	<b>Percent of Total ERUs</b>
Residential – SF <sup>(4)</sup>	71,350,000	725	725	1.0	44.0%
Residential – MF	16,247,000	56	165	2.9	10.0%
Commercial	25,853,000	143	263	1.8	15.9%
Rural	4,373,000	31	44	1.4	2.7%
School	18,763,000	10	191	19.1	11.6%
City	21,401,000	16	217	13.6	13.2%
PFWA	4,207,000	45	43	0.9	2.6%
<b>Total</b>	<b>162,194,000</b>	<b>1026</b>	<b>1648</b>	<b>- -</b>	<b>100%</b>

- (1) Based on the City’s 2014 water reports; including PFWA consumption.
- (2) Number of connections from Table 2-1 plus 45 PFWA connections.
- (3) ERUs = (Average Day Consumption) / (270 gpd/ERU); includes PFWA ERUs.
- (4) Includes PFWA consumption.

**EAST SIDE EQUIVALENT RESIDENTIAL UNITS**

By comparing the annual water use records for areas east of the Okanogan River it was found that water use on the east side of the Okanogan River is equivalent to approximately 100 ERUs, equating to approximately 8 percent of the City’s total ERUs. This usage amounts to approximately 50 ac-ft/yr. These demands are included in the previous tables.

**LARGEST WATER USERS**

Water consumption by the ten largest water users in the City of Okanogan is shown in Table 2-8. These commercial customers accounted for approximately 24 percent of metered consumption in 2014. Note that the Okanogan Jr./Sr. High School usage accounts for approximately 11 percent of the total water system consumption. Peak consumption patterns among the large water users are important because of modest increase or decrease in consumption by a large water user could significantly increase/decrease the demands on the water system.

**TABLE 2-8**

**2014 Largest Water Users**

Name	Consumption (gal)		% of Total
	Location	2014 <sup>(1)</sup>	
Jr./Sr. High School Baseball Field #1	1041 7 <sup>th</sup> Ave, S.	5,227,000	3%
County Jail	149 3 <sup>rd</sup> Ave, N.	5,107,000	3%
Jr./Sr. High School Ag Building	334 5 <sup>th</sup> Ave, S.	5,106,000	3%
Jr./Sr. High School Kitchen	230 5 <sup>th</sup> Ave, S.	4,885,000	3%
Progressive Flats Water Association	Rural 142, Conconully Rd.	4,207,000	3%
Anweiler, LLC	23268 Hwy 20	3,168,000	2%
Jr./Sr. High School Baseball Field #2	1302 Nickell Str.	2,881,000	2%
Elmwood Apartments	880 2 <sup>nd</sup> Ave, S.	2,622,000	2%
County Courthouse	149 3 <sup>rd</sup> Ave, N.	2,517,000	2%
Valley Care Center	235 Tyee	2,472,000	2%
<b>Total</b>		<b>38,192,000</b>	<b>24%</b>

(1) As a percentage of Total Annual Consumption, 2014 (See Table 2-7).

**IRRIGATION WATER CONSUMPTION**

According to the City, approximately 30 percent of the City’s water system connections are served by separate non-potable irrigation water provided by local irrigation districts. Because irrigation water is not currently metered from the non-potable water irrigation system serving the area within the UGA, it is not known how much irrigation water is consumed by these residents.

**PROJECTED LAND USE, FUTURE POPULATION, AND WATER DEMANDS**

This section provides population and water use projections based on the historical data presented in the previous sections.

**PROJECTED POPULATION**

The City of Okanogan Comprehensive Plan (2003) provides three population forecasts (Low, Medium and High) out to the year 2022. These forecasts equate to annual growth rates of 0.85 percent, 1.28 percent and 1.90 percent. The average annual growth rate of the City since 2010 has been approximately 0.42 percent. For the purposes of this Plan, the City has projected a population growth of 0.42 percent as agreed upon with the City’s planning department.

**Progressive Flats Water Association**

The City wholesales water to the PFWA (per agreement in November, 2006). In the Progressive Flats Domestic Water System, Preliminary Engineering Report (Final), the

projected growth for the PFWA was assumed to be 1.3 percent, which is slightly higher than the City’s projected growth rate of 0.42 percent. The population of the City (approximately 2,595 in 2014) far exceeds that of the PFWA, therefore the growth rate used for these water system planning projections has been selected to be 0.42 percent. For total service area population, in 2014, the PFWA has 45 residential connections. From the City of Okanogan Water System Plan Update (2009), it can be derived that there are approximately 3 persons per residence in the City of Okanogan. Assuming that the PFWA persons per residence ratio will be similar to this ratio in Okanogan, there are an estimated 135 persons in the PFWA. The historical population trends for the City of Okanogan were previously shown in Figure 2-1. The PFWA population and water use will be included when projecting future needs of the Okanogan water system.

**PROJECTED ERUS**

The City’s current zoning is shown on Figure 1-3. As discussed in Chapter 1, the City’s existing land use is nearly the same as the zoning shown on Figure 1-3. Based on the City of Okanogan Comprehensive Plan (2003), future land use is expected to continue to be shaped by the City’s zoning. Growth of ERUs has been projected based upon growth in projected population.

Projected ERUs are shown in Table 2-9.

**TABLE 2-9**

**Projected ERUs**

Year	Population		ERUs <sup>(1)</sup>						
	Resid. City	Resid. PFWA	Resid. SF <sup>(2)</sup>	Resid. MF <sup>(3)</sup>	Rural	Com-mercial	City	Schools	Total
2015	2,606	136	816	166	45	264	218	191	1,700
2016	2,617	136	819	166	45	265	219	192	1,707
2017	2,628	137	823	167	45	266	220	193	1,714
2018	2,639	137	826	168	45	267	221	194	1,721
2019	2,650	138	829	169	45	268	222	195	1,728
2020	2,661	138	833	169	46	269	223	196	1,735
<b>2021<sup>(4)</sup></b>	<b>2,672</b>	<b>139</b>	<b>836</b>	<b>170</b>	<b>46</b>	<b>270</b>	<b>224</b>	<b>196</b>	<b>1,743</b>
<b>2035<sup>(5)</sup></b>	<b>2,833</b>	<b>147</b>	<b>887</b>	<b>180</b>	<b>49</b>	<b>287</b>	<b>237</b>	<b>208</b>	<b>1,848</b>

- (1) All ERUs are projected to increase at 0.42 percent per year. Residential SF ERUs include both City and PFWA residential ERUs.
- (2) SF = single-family residence
- (3) MF = multi-family residence
- (4) 6-year planning horizon
- (5) 20-year planning horizon

**PROJECTED ADD, MDD, AND PHD**

Because the City’s water needs are served jointly by the City’s potable drinking water and two irrigation districts, (Alta Vista and Okanogan irrigation districts) for irrigation water, the ability of the irrigation districts to continue to supply irrigation water to the area within the UGA was assumed to continue in forecasting future water demand. It is assumed for the purposes of this plan that the City will continue to supply irrigation water to its customers within City limits not already served by an irrigation district (Figure 1-3).

DOH requires planning for six and twenty year planning horizons. Table 2-10 shows the projected population, consumption, ADD, MDD and PHD through 2035. Projected water demands were based on the projected growth rate of 0.42 percent and the 2010–2014 ADD (547,000, as shown in Table 2-2).

The production data was used to project the peak day and peak hour demands through the year 2035 by applying the peak day peak factor of 2.2 and peak hour peaking factor 1.8 to the average day production and the peak day production, respectively.

**TABLE 2-10**

**Projected ADD, MDD, and PHD**

<b>Year</b>	<b>Service Area Pop.<sup>(1)</sup></b>	<b>ERUs<sup>(1)</sup></b>	<b>ADD<sup>(2)</sup> (gpd)</b>	<b>Annual Prod. (af/yr)<sup>(3)</sup></b>	<b>MDD<sup>(4)</sup> (gpd)</b>	<b>MDD<sup>(5)</sup> (gpm)</b>	<b>PHD<sup>(6)</sup> (gpm)</b>
2015	2,742	1,700	563,000	630	1,239,000	860	1,508
2016	2,753	1,707	565,000	630	1,243,000	860	1,508
2017	2,765	1,714	567,000	640	1,247,000	870	1,525
2018	2,776	1,721	570,000	640	1,254,000	870	1,525
2019	2,788	1,728	572,000	640	1,258,000	870	1,525
2020	2,799	1,735	575,000	640	1,265,000	880	1,543
<b>2021</b>	<b>2,811</b>	<b>1,743</b>	<b>577,000</b>	<b>650</b>	<b>1,269,000</b>	<b>880</b>	<b>1,543</b>
<b>2035</b>	<b>2,980</b>	<b>1,848</b>	<b>612,000</b>	<b>690</b>	<b>1,346,000</b>	<b>930</b>	<b>1,630</b>

- (1) Combined City and PFWA, from Table 2-9.
- (2) ADD was assumed to increase at the same rate as ERUs. See Table 2-7 for calculation of ERUs. The 2010-2014 average ADD shown in Table 2-2 was used as the basis for projections.
- (3) Annual Production = ADD \* 365 ÷ 43,560 cf/af ÷ 7.48 gal/cf (rounded to the nearest 10 acre-feet).
- (4) MDD/ADD peaking factor = 2.2 (Table 2-3).
- (5) MDD (gpm) = MDD (gpd) ÷ 1,440 min/day.
- (6) PHD/MDD peaking factor = 1.8.

## **WATER USE EFFICIENCY**

The City of Okanogan draws water from an aquifer which is in hydraulic continuity with the surface waters of the Okanogan River. The City has historically been careful about water use and has taken the following measures to encourage water conservation in the community:

- Program Promotion - the City makes Health's water conservation flyers available at City Hall and encourages water conservation in its annual Consumer Confidence Report.
- Source Meters - the City's active wells are equipped with source meters. Data is collected and saved at the Wastewater Treatment Facility by the City's telemetry system.
- Service Meters - the entire City's residential, commercial, and industrial water customers are metered.
- Conservation Rates - the City has adopted a conservation rate structure that consists of a base rate and volume charge (see Table 9-1 and Table 9-2).
- Distribution System Leakage – the City has reduced its DSL rate to an average of just over 10 percent over the last 3 years (2012-2014).

The demand estimates provided in Table 2-11 will be used for a conservative analysis of the City's water system infrastructure without allowances for further conservation. However, the City anticipates making any future rate adjustments with further conservation in mind. The City's goal is to reduce its per capita consumption by 3 percent for the 6-year planning period.

The distribution system leakage (DSL) percentage is projected to decrease from the three-year average value of just over 10 percent to 8 percent over the next six years through ongoing leak detection and repairs, and replacement of transmission lines. Projected yearly savings through measures to reduce distribution system leakage and decreased consumption from 2016 to 2021 are shown in Table 2-12.

**TABLE 2-11**

**Projected ADD, MDD & PHD with Conservation**

Year	Service Area Pop. <sup>(1)</sup>	ERUs <sup>(2)</sup>	ADD <sup>(3)</sup> (gpd)	Annual Prod. <sup>(4)</sup> (af/yr)	MDD <sup>(5)</sup> (gpd)	MDD <sup>(6)</sup> (gpm)	PHD <sup>(7)</sup> (gpm)
2015	2,742	1,700	563,000	630	1,239,000	860	1,508
2016	2,753	1,707	560,000	630	1,232,000	860	1,508
2017	2,765	1,714	560,000	630	1,232,000	860	1,508
2018	2,776	1,721	559,000	630	1,230,000	850	1,490
2019	2,788	1,728	559,000	630	1,230,000	850	1,490
2020	2,799	1,735	558,000	630	1,228,000	850	1,490
<b>2021<sup>(8)</sup></b>	<b>2,811</b>	<b>1,743</b>	<b>558,000</b>	<b>630</b>	<b>1,228,000</b>	<b>850</b>	<b>1,490</b>
<b>2035<sup>(9)</sup></b>	<b>2,980</b>	<b>1,848</b>	<b>593,000</b>	<b>660</b>	<b>1,305,000</b>	<b>910</b>	<b>1,595</b>

- (1) Combined population of City and PFWA from Table 2-9.
- (2) Total ERUs from Table 2-9.
- (3) ADD = Population x gpcd, with a 3-year average DSL reduction of just over 2 percent (from just over 10 percent to 8 percent) over a 6-year period.
- (4) Annual Production = ADD \* 365 days/yr ÷ 43,560 cf/af ÷ 7.48 gal/cf (rounded to the nearest 10 acre-feet).
- (5) MDD/ADD peaking factor = 2.2 (Table 2-3).
- (6) MDD (gpm) = MDD (gpd) ÷ 1,440 min/day.
- (7) PHD/MDD peaking factor = 1.8.
- (8) 6-year planning horizon.
- (9) 20-year planning horizon.

**TABLE 2-12**

**Projected Savings with DSL Improvements and Reduced Consumption**

Year	DSL Savings <sup>(1)</sup> (gal)	Consumption Savings <sup>(2)</sup> (gal)	Total Savings (gal)
2013	2,200	2,800	5,000
2017	3,100	3,900	7,000
2018	4,900	6,100	11,000
2019	5,800	7,200	13,000
2020	7,600	9,400	17,000
2021	8,400	10,600	19,000
<b>Total</b>	<b>32,000</b>	<b>40,000</b>	<b>72,000</b>

- (1) Savings assumes reduction of 0.4 percent per year for a total of 2.4 percent over 6 years.
- (2) Savings assumes reduction of 0.5 percent per year for a total of 3.0 percent over 6 years.



## CHAPTER 3

### WATER SYSTEM ANALYSIS

The purpose of this chapter is to determine the ability of the City's existing water system to meet current and future water quality and system demand requirements. The major sections of this chapter are:

- System Design Standards
- Water Quality Analysis
- Facility Analysis
- Operation and Maintenance Analysis
- System Deficiencies and Proposed Improvements

#### SYSTEM DESIGN STANDARDS

WAC 246-290 contains general criteria and standards that must be followed in the development of public water systems. In addition, the Washington State Department of Health's 2009 Water System Design Manual (WSDM) provides specific guidance for water system design.

#### GENERAL FACILITY STANDARDS

The Department of Health (Health) relies on various regulations, publications, and the purveyor to establish design criteria. WAC 246-290 is the primary drinking water regulation used by Health to assess capacity, water quality, and compliance with drinking water standards. The WSDM serves as guidance for the preparation of plans and specifications for Group A public water systems in compliance with WAC 246-290. The WSDM also references the following codes and guidelines:

- Uniform Building Code (the International Building Code was adopted by all state and local agencies in 2004);
- Uniform Plumbing Code;
- Recommended Standards for Water Works (RSWW), Ten State Standards;
- Local codes;
- American Water Works Association (AWWA) Standards;
- American Society of Civil Engineers (ASCE) Standards; and
- American Public Works Association (APWA) Standards.

Table 3-1 lists the suggested WSDM guidance and the City's policies with regard to each standard for general facility requirements.

**TABLE 3-1**

**General Facility Requirements**

Standard	Department of Health Water System Design Manual	City of Okanogan Standards
Average Day and Maximum Day Demand	Average Day Demand (ADD) should be determined from metered water use data. Maximum Day Demand (MDD) is estimated at approximately two times the ADD if metered data is not available.	ADD = Metered consumption MDD = Based on 2.2 peaking factor on historical average day demand data
Peak Hour Demand	Peak hour demand (PHD) is determined using the following equation:  $PHD = (MDD/1440)(CN + F) + 18,$ where MDD is in gpd/ERU, and C and F are coefficients based on N, the number of ERUs. See Eq. 5-3, WSDM	PHD = Applying 1.8 peaking factor to MDD based on metered consumption
Source Capacity	Capacity must be sufficient to meet MDD and replenish fire suppression storage within 72 hours.	Same as WSDM, Chapter 7.
Storage Requirements	The sum of: <u>Operational Storage</u> Volume sufficient to prevent pump recycling. <u>Equalizing Storage</u> $V_{ES} = (Q_{PH} - Q_S) * 150$ <u>Standby Storage</u> $V_{SB} = (2 * ADD * N) - t_m * (Q_S - Q_L)$ <u>Fire Suppression Storage</u> $V_{FSS} = NFF * T$ Where, ADD = average day demand, gpd/ERU N = number of ERU's Q <sub>PH</sub> = peak hour demand, gpm Q <sub>S</sub> = capacity of all sources, excluding emergency sources, gpm Q <sub>L</sub> = capacity of largest source, gpm t <sub>m</sub> = daily pump source run time, min (1440) NFF = needed fire flow, gpm T = fire flow duration, min	Same as WSDM, using the formulas provided in the manual, Chapter 9.
Minimum System Pressure	The system should be designed to maintain a minimum of 30 psi in the distribution system under peak hour demand and 20 psi under fire flow conditions during MDD.	Same as WSDM, Chapter 8.
Fire Flow Rate & Duration	The minimum fire flow shall be determined by the local fire authority.	Fire flow requirements are based on the local Fire Department standards which follow the International Fire Code (IFC).
Minimum Pipe Size	The diameter of a transmission line shall be determined by hydraulic analysis. The minimum size distribution system line shall not be less than 6-inches in diameter.	Same as WSDM, Chapter 8.

**TABLE 3-1 (cont.)**

**General Facility Requirements**

Standard	Department of Health Water System Design Manual	City of Okanogan Standards
Reliability Recommendations	<ul style="list-style-type: none"> <li>• Sources capable of supplying MDD within an 18-hour period</li> <li>• Sources meet ADD with largest source out of service</li> <li>• Back-up power equipment for pump stations unless there are two independent public power sources</li> <li>• Provision of multiple storage tanks</li> <li>• Standby storage equivalent to ADD x 2, with a minimum of 200 gpd/ERU</li> <li>• Low and high level storage alarms</li> <li>• Looping of distribution mains when feasible</li> <li>• Pipeline velocities not &gt; 8 fps at PHD</li> <li>• Flushing velocities of 2.5 fps for all pipelines</li> </ul>	Same as WSDM, Chapter 5.
Valve and Hydrant Spacing	Sufficient valving should be placed to keep a minimum of customers out of service when water is turned off for maintenance, repair, replacement or addition. As a general rule, valves on distribution mains 12-inches and smaller should be provided at least every 1,000 feet. Fire hydrants on laterals should be provided with their own auxiliary gate valve.	The City has adopted the International Fire Code (IFC). Valve spacing distances are recommended per IFC App. C.
Water Quality Standards	The primary drinking water regulation utilized by Health to assess capacity, water quality, and overall compliance with drinking water standards.	WAC 246-290

**CONSTRUCTION STANDARDS**

The City has prepared a set of standards for developers to follow when constructing water system components. These standards are included in Chapter 7.

**WATER QUALITY ANALYSIS**

Group A public community water systems must comply with the drinking water standards of the federal Safe Drinking Water Act and its amendments. The Washington State Department of Health adopted these federal standards under WAC 246-290. To enable Group A water systems to comply with the regulations, Health issues Water Quality Monitoring Report's (WQMR) listing a system's reporting requirements. The City's current WQMR is provided in Appendix B.

The City is currently in compliance with all bacteriological, organic, and inorganic testing. According to the DOH Office of Drinking Water website, the City has had six positive total coliform tests in the four year period from 2010 to 2014. Every year since 2012 there has been one exceedance of arsenic at Well No. 4. Raw water withdrawn

from Well No. 4 exceeds the EPA’s recently lowered maximum contaminant level (MCL) for arsenic. The City’s arsenic treatment facility treats this water to lower arsenic levels below the MCL prior to introduction into the City’s water distribution system. Water withdrawn from the City’s other wells have not experienced arsenic levels.

The City is concerned about the risk to public health posed by non-compliant private and public water systems located within the City’s service area. The City has been made aware that at least one water system is in use in the Elmway area (Way S, ID #27676) that may pose an elevated level of risk to public health, as they provide water used for food preparation/service, rather than just residential consumption. The City will explore opportunities to seek state funding through the Drinking Water State Revolving Fund, or other appropriate sources, to extend public water to serve the Elmway community and allow consolidation of these water systems.

## FACILITY ANALYSIS

This section presents an evaluation of the City’s water system source, storage, transmission, distribution, and telemetry facilities.

### SOURCE

Department of Health rules, as described in WAC 246-290-222 (4), require source production capacity to be sufficient to supply maximum day demands. In addition, the City’s water rights must be sufficient to meet maximum day and total annual demands.

#### Source Capacity

As indicated in Chapter 1, the City has four operative wells, Wells No. 2, 3, 4 and 5. The following analyses have been performed assuming the capacities of these wells. A summary of the City’s ground water sources is presented in Chapter 1. Table 3-2 compares the peak daily well production capacity of the existing wells with projected peak day production requirements through the year 2035.

**TABLE 3-2**

#### Source Production Capacity Analysis

Year	MDD (gpm)	Source Capacity(1) (gpm)	Surplus (+)/Deficit (-) (gpm)
2015	860	1,825	+965
2021 <sup>(2)</sup>	880	1,825	+945
2035 <sup>(3)</sup>	930	1,825	+895

(1) Current primary sources, Well No. 2 (200 gpm) + Well No. 3 (650 gpm) + Well No. 4 (550 gpm) + Well No. 5 (425 gpm) = 1,825 gpm.

(2) 6-year planning horizon

(3) 20-year planning horizon

Table 3-2 indicates that the City’s primary wells have sufficient rated pumping capacity to meet the MDD through the 20-year planning period. The City’s wells all have flow control valves and may be operated at a lower output than full capacity at the City’s option.

Besides the requirements of WAC 246-290-222 (4), the WSDM recommends that systems wishing to provide a high level of reliability to its customers consider the following source criteria for emergency conditions:

- Provide sufficient source capacity to meet the MDD and replenish fire suppression storage within 72 hours. (The largest fire suppression storage requirement is 1,320,000 gallons (5,500 gpm for 4 hours)).
- Meet the MDD with 18 (rather than 24) hours of pumping.
- Meet the ADD with the largest source out of service.
- Provide two independent power feeds, or portable or in-place backup power unless the power grid meets the following minimum reliability criteria:
  - Outage frequency averages three or less per year based on data for the three previous years with no more than six outages in a single year. A power outage is considered a loss of power for 30 minutes or longer.
  - Outage duration averages less than four hours based on data for the three previous years with not more than one outage during the three previous year period exceeding eight hours.

Table 3-3 summarizes the City’s ability to meet the first three of these recommendations.

**TABLE 3-3**

**2035 Source Production Capacity Analysis<sup>(1)</sup>**

Criteria	Q(req’d) (gpm)	Q(avail) (gpm)	Surplus (+) / Deficit (-) (gpm)
Meet MDD & Replenish FSS within 72 Hours <sup>(2)</sup>	1,236	1,825	+589
Meet MDD with 18 Hours Pumping	930	1,369	+439
Meet ADD without Largest Source <sup>(3)</sup>	424	1,175	+751

(1) Assumes source capacity provided by Well No. 2 (200 gpm) + Well No. 3 (650 gpm) + Well No. 4 (550 gpm) + Well No. 5 (425 gpm) = 1,825 gpm

(2) 2035 MDD = 930 gpm (Table 2-11). FSS = 1,320,000 gal (5,500 gpm for 4 hours).  
∴ Q(req’d) = 930 + (1,320,000 ÷ (72 \* 60)) = 1,236 gpm

(3) 2035 ADD = 611,000 gpd (Table 2-11) ÷ 60 ÷ 24 = 424 gpm

Table 3-3 indicates that the City’s wells are expected to meet the MDD and replenish the reservoirs with the Fire Suppression Storage (FSS) within 72 hours, and to meet the MDD with 18 (rather than 24) hours of pumping. The City’s wells are also expected to meet the ADD with the largest source out of service.

Regarding the fourth recommendation, available power records from the Okanogan Public Utility District (PUD) indicate many outages have occurred lasting a half hour or longer over the last three years. The City averaged 11 outages per year from 2013 through June 2015. In 2013 and 2014 there were 13 and 16 outages each year, respectively, exceeding the maximum 6 outages per year limit set by DOH for reliability. In terms of outage duration, the City meets the DOH reliability requirements as the 3-year average outage duration is 2.3 hours, which is less than the four hour maximum. Additionally, only one power outage in the previous three years has exceeded eight hours in duration. The City is fed by only one power source (one substation) and there is currently no backup power at any of the City's wells. The City's reservoirs could provide sufficient standby storage during an extended outage, as indicated later in this chapter.

Although the City meets the first three reliability criteria provided by the DOH WSDM for increased reliability to the water system, the fourth criteria has not been met as outage frequency has exceeded the recommended quantity. In order to improve reliability of the water system, a backup generator capable of powering the largest capacity well should be installed as part of the new capital improvements.

## **Water Rights**

A summary of the City's water rights was presented in Table 1-5. The City's maximum instantaneous and annual withdrawals for each source must comply with the limitations of its water rights. Appendix K provides copies of selected information from Ecology's water rights files as well as Ecology's Reports of Examination for these water rights and claims. Figure 1-1 shows the place of use for the City's water rights.

Table 3-4 provides an analysis of the current and projected adequacy of the City's water rights, using the DOH format table for water rights self assessment. The table shows totals for the current water rights as well as the 2015, 2021 and 2035 expected water consumption for the City's active sources. As indicated, the City's total available water rights are not expected to exceed its needs by the year 2035. Note that for these tables, it has been assumed that the City will have the Watercress Springs source back in service as it is the City's intention that the claim associated with the Springs will be put to use either at the Springs or be transferred to other points of withdrawal within the City.

At the City's Sports Complex (located east of the Okanogan River on tribal lands) on the parcel of land the City purchased from Mr. Warren Dickson in 1998, the Confederated Tribes of the Colville Reservation have issued Permit No. 99-06-04-11G to the City of Okanogan on March 6, 2000 for 270 gpm and 92.31 acre-feet for the purpose of irrigating sports fields. This permit may be revoked if "found necessary to protect Okanogan River Fishery." Additionally, in the recommendations for application approval from the Colville Confederated Tribes Natural Resources Committee, it states "This water will not be co-mingled with the City of Okanogan municipal water system."

**TABLE 3-4**

**Water Rights Self-Assessment**

Permit Certificate or Claim #	Name of Right Holder or Claimant	Priority Date	Source Name/ Number	Primary, Additive or Non-Additive	Existing System Capacity - based on Water Right Limits		Water Right Requirement (Assumed to be Pump Rate & ADD)		Projected System Capacity Status +/-(-)	
					Maximum Instantaneous Flow Rate (Qi) (gpm)	Maximum Annual Volume (Qa) (ac-ft)	Maximum Instantaneous Flow Rate (Qi)	Maximum Annual Volume (Qa)	Maximum Instantaneous Flow Rate (Qi)	Maximum Annual Volume (Qa)
CG4-GWC266-D	City of Okanogan	1924	Well No. 1	NA <sup>(1)</sup>	100	29	0	0	+100	+29
CG4-GWC369-A	City of Okanogan	7/27/46	Well No. 5	NA <sup>(1)(2)</sup>	350	200	200	50	+150	+150
GWC 03410-A	City of Okanogan	2/21/48	Well No. 2	NA <sup>(1)(3)</sup>	200	320	200	70	0	+250
CG4-GWC3838-A	PFWA <sup>(6)</sup>	8/12/60	Well No. 3	None	50	39	0	0	+50	+39
GWC-5327-A	City of Okanogan	9/13/63	Well No. 3	NA <sup>(1)</sup>	650	700	650	225	0	+475
G4-23854C	City of Okanogan	12/24/75	Well No. 4	None	550	400	550	190	0	+210
G4-29193P	City of Okanogan	1/30/87	Well No. 5	NA <sup>(4)</sup>	300	400	225	94	+75	+306
CG4-30573	PFWA <sup>(6)</sup>	1/22/91	Well No. 3	None	20	6.3	0	0	+20	+6.3
S4-000052C1	City of Okanogan	1908	Watercr. Sp	NA <sup>(4)</sup>	300	484	0	0	+300	+484
<b>TOTAL</b>					<b>2,520</b>	<b>1,629.3</b>	1,825	629	+695	+1000.3
<b>EXISTING MODIFIED TOTAL<sup>(5)</sup></b>					<b>2,220</b>	<b>1,629.3</b>	1,825	629	+395	+1000.3
2021 Total (6-year)					2,520/2,220 <sup>(5)</sup>	<b>1,629.3</b>	1,825	646	+695/+395	+983.3
2035 Total (20-year)					2,520/2,220 <sup>(5)</sup>	<b>1,629.3</b>	1,825	684	+695/+395	+945.3
Intertie Name/Identifier		Name of Purveyor Providing Water			Existing Limits on Intertie Water Use		Proj. Production/Withdrawal with New Project On-line		Current Intertie Supply Status (Excess/Deficiency)	
					Maximum Instantaneous Flow Rate (Qi)	Maximum Annual Volume (Qa)	Maximum Instantaneous Flow Rate (Qi)	Maximum Annual Volume (Qa)	Maximum Instantaneous Flow Rate (Qi)	Maximum Annual Volume (Qa)
N/A		N/A			N/A	N/A	N/A	N/A	N/A	N/A
Pending Water Right Appl.	Name on Application	Priority Date	Source Name	Additive or Non-Additive	Maximum Instantaneous Flow Rate (Qi)	Maximum Annual Volume (Qa)				
N/A	N/A	N/A	N/A	N/A	N/A	N/A				

- (1) Certificate GWC-5327 was issued with the special provision that the annual quantity of withdrawal is non-additive to SW Certificate 592 and GW Certificates 265, 266, 369A, and 3410. The total withdrawal allowed under all of these certificates was limited to 700 ac-ft/yr. The City has since relinquished SW Certificate 592 and GW Certificate 265. Certificate 266-D is restricted to season of use from April 1 to October 31.
- (2) This right was originally held under Certificate 369-A for Well No. 1 and was transferred to Well No. 5 on 7/20/87. This certificate is included in the 700 ac-ft/yr cap identified in the 1963 Well No. 3 certificate.
- (3) The Record of Examination on this right states that at the time this certificate was issued, the City held SW Certificate 592 and GW Certificates 265,266, and 369A for a total of 1675 gpm and 1488 ac-ft/yr. the 320 ac-ft annual portion of this right was issued non-additive to these rights. SW Certificate 592 was subsequently relinquished.
- (4) The annual quantity of the Permit G4-29193P was issued non-additive to the City’s Ground Water Certificates No. 266-D, 369-D, 3410-A, 5327-A, G4-23854C, and Water Right Claim No. S4-000052C1 should a right be confirmed following an adjudication. The instantaneous portion of the permit was also issued non-additive, subject to minimum Okanogan River flows and Certificate of Change 369-A. The City issued the Proof of Appropriation in 1988. The DOE wrote in a subsequent correspondence that a certificate for this well would be issued following a final DOE inspection.
- (5) Water Rights Totals when the Okanogan River is below minimum flows.
- (6) PFWA = Progressive Flats Water Association. PFWA transferred its water rights for two certificates to Well No. 3 because of radionuclide pollution and declining water levels.

The Watercress Springs source was taken out of service after the Department of Health identified the source as Groundwater Under the Direct Influence of Surface Water (GWI) in 2003. According to the letter dated May 8, 2003 to the City, in order to comply with the requirements of the Surface Water Treatment Rule (SWTR), the City has the following options:

- Keep the source disconnected from the public water system;
- Install filtration and all necessary disinfection improvements to meet the full treatment requirements of the SWTR;
- Reconstruct the GWI source, if possible to eliminate the surface water influence;
- Qualify for the criteria to remain unfiltered per WAC 246-290-690, if possible. (Note that future requirements more stringent than the current requirements may be developed under the Long-Term Enhanced Surface Water Treatment Rule); or
- Satisfy the criteria for unfiltered systems with a “limited alternative to filtration” per WAC 246-290-691.

The City intends to bring this source back on-line within the 20-year planning period, or possibly to transfer this claim to another point of withdrawal. The City is considering improving the source using option one, by adding filtration and disinfection to meet the SWTR in the 20-year planning period.

The Riverwalk Well (Well No. 6) is also anticipated as a capital improvement in the 20-year planning period. This well is located at the north end of the water system which would provide additional source capacity at the far northeast end of the City. There is an existing private well located at the Riverwalk development that will be replaced by the proposed City well.

It is the City’s intention to consolidate their water rights in order to provide additional flexibility for groundwater withdrawal for municipal uses.

## **STORAGE**

As outlined in the WSDM, storage requirements are based on the sum of the following storage components:

- Operating storage;
- Equalizing storage;
- Standby storage; and
- Fire suppression storage.



### Operating Storage (OS)

Operating storage is the amount of storage taken up by the first few feet of the reservoir to account for cycling of the supply pumps. The City of Okanogan has generally used the top five feet of its reservoirs for this purpose.

### Equalizing Storage (ES)

Equalizing storage is used to meet diurnal peaks that exceed the average demand during MDD. The volume of equalizing storage required depends on peak system demands, the magnitude of diurnal water system demand variations, the source production rate, and the mode of system operation. Equalizing storage must be provided at a minimum pressure of 30 psi.

$$V_{ES} = (Q_{PH} - Q_S) * 150 \text{ minutes,}$$

where,

$$V_{ES} = \text{Volume of equalizing storage (gallons)}$$

$$Q_{PH} = \text{Peak hourly demand (gpm)}$$

$$Q_S = \text{Total capacity of source supply, excluding emergency sources (gpm)}$$

### Standby Storage (SB)

Standby storage provides a measure of reliability should the City's source of supply fail, or should unusual conditions create increased system demands. Standby storage calculations are based on the assumption that adequate source capacity will be developed to meet average daily demands with the largest source out of service. Standby storage must be provided at a minimum pressure of 20 psi.

$$V_{SB} = 2 \text{ days} * (ADD) - t_m * (Q_S - Q_L)$$

where,

$$V_{SB} = \text{Required volume of standby storage (gallons)}$$

$$ADD = \text{Average daily demand for the design year (gal/day)}$$

$$t_m = \text{Time remaining sources are pumped when the largest source is unavailable (minutes). Usually taken conservatively as 1,440 minutes, or one day.}$$

$$Q_S = \text{Rate of all source capacities summed together, except emergency sources (gpm)}$$

$$Q_L = \text{Rate of largest capacity source available to system (gpm)}$$

In no case, however, shall the standby storage volume be less than the following:

$$V_{SB} = 200 \text{ gallons times the number of ERUs}$$

### Fire Suppression Storage (FSS)

The amount of water required for fire fighting purposes is specified in terms of rate of flow in gallons per minute (gpm) for an associated duration. The City's fire chief, whose

advice the City relies on for matters related to fire flow, has indicated that a peak fire flow requirement of 5,500 gpm for a 240-minute duration is appropriate for the City’s highest fire flow requirement. Fire flows must be provided at a residual water system pressure of at least 20 psi.

$$V_{FSS} = NFF * T,$$

where,

$$V_{FSS} = \text{Volume required for fire suppression storage (gallons)}$$

$$NFF = \text{Needed fire flow (gpm)}$$

$$T = \text{Flow duration (minutes)}$$

WAC 246-290-235(4) allows standby and fire suppression storage volumes to be combined or “nested”, provided the local fire protection authority does not require them to be additive. A copy of the “Fire Flow Requirement for Large Structures” as provided by the City’s Fire Chief, in addition to email correspondence related to large structures and fire flow requirements, are provided at the end of Appendix G, Emergency Response Plan.

**Total Storage Requirements**

Table 3-5 shows the storage volumes available in the City’s five reservoirs (East, North, Highland, and West Reservoirs No. 1 and 2) for the next 20 years. Note that in both Tables 3-5 and 3-6, it has been assumed that for the 20-year planning period a new reservoir serving the Murray pressure zone (Murray Reservoir) is presumed to be constructed (with a new transfer station) to provide an additional 200,000 gallons of storage. The 400,000-gallon Watercress Springs Reservoir, which is currently out of service, has not been included in these calculations.

**TABLE 3-5**  
**Storage Volume Components<sup>(1)</sup>**

<b>Year</b>	<b>OS <sup>(2)</sup></b>	<b>ES <sup>(3)</sup></b>	<b>Recommended SB <sup>(4)</sup></b>	<b>Minimum req’d. SB <sup>(5)</sup></b>	<b>FSS <sup>(6)</sup></b>
2015	386,000	0	0	340,000	1,320,000
2021	386,000	0	0	349,000	1,320,000
2035	426,000	0	0	370,000	1,320,000

- (1) Includes East, North, Highland, and West Reservoirs No. 1 and No. 2.
- (2) OS = 4 ft. Operating storage is expected to remain constant over the planning period. Note that for year 2035, OS has been increased to account for additional storage as detailed in discussion above.
- (3)  $ES = (Q_p - Q_s) * 150 \text{ minutes} \leq 0$ , therefore use zero
- (4)  $SB \text{ (recommended volume)} = 2 * (ADD) - t_m (Q_S - Q_L)$ , where  $t_m = 1,440$
- (5)  $SB \text{ (minimum volume)} = 200 * ERUs$
- (6)  $FSS = 5,500 \text{ gpm} * 240 \text{ min} = 1,320,000 \text{ gal}$

**TABLE 3-6**

**Storage Volume Summary<sup>(1)</sup>**

<b>Year</b>	<b>Total Storage Provided</b>	<b>Total Required<sup>(2)</sup></b>	<b>Surplus (or Deficit) Without Nested SB<sup>(3)</sup></b>	<b>Surplus (or Deficit) With Nested SB<sup>(4)</sup></b>
2015	1,710,000	1,706,000	(336,000)	4,000
2021	1,710,000	1,706,000	(345,000)	4,000
2035	1,910,000	1,746,000	(206,000)	+164,000

- (1) Volumes for 2035 includes the proposed Murray Reservoir.
- (2) Total Required = OS + ES + FSS and assume the SB is nested within the FSS.
- (3) This is the difference between the storage volume provided and the storage volume required without nesting SB within FSS.
- (4) This is the difference between the storage volume provided and the storage volume required with nesting SB within FSS.

As indicated in Table 3-6, the City’s total storage capacity in 2015 for its five (5) active reservoirs is approximately 1,710,000 gallons. The total requirements per WSDM for storage capacity can currently be provided through 2035 with standby storage nested within the fire suppression storage volume.

Table 3-7 indicates reservoir elevations and static service pressures for each storage volume component for 2035 for the lower pressure zone. The total storage volume of 1,910,000 gallons shown in Table 3-7 includes the Highland and proposed Murray reservoir storage volumes since pressure relief valves will allow the transfer of water from the Highland and Murray pressure zones to the lower pressure zone. This table indicates that the City will be able to provide more than the minimum 30 psi when OS, ES, SB and FSS are depleted. The City will also be able to provide the required fire suppression storage and still maintain a static pressure minimum 50 psi at the highest service elevation.

**TABLE 3-7**

**2035 Storage Analysis – Lower Pressure Zone**

Component	Reservoir Elevation (ft)	High Static Pressure <sup>(1)</sup> (psi)	Low Static Pressure <sup>(2)</sup> (psi)	Storage (rounded, gal)		
				Actual	Required	Surplus (+) Deficit (-)
Top of Storage	1064.0	59	105	-	-	-
Operational (OS)	1060.0	57	103	426,000	426,000	-
Equalization (ES)	1059.8	57	103	20,000	-	+20,000
Fire Suppression (FSS)	1044.0	50	96	1,464,000	1,320,000	+144,000
Standby (SB) <sup>(3)</sup>	1044.0	50	96	-	-	-
<b>Total Storage</b>				<b>1,910,000</b>	<b>1,746,000</b>	<b>+164,000</b>

- (1) Highest service connection in main pressure zone = 928 ft. Estimated from USGS quad sheet with 20-foot contours.
- (2) Lowest service connection in main pressure zone = 822 ft. Estimated from USGS quad sheet with 20-foot contours.
- (3) Standby storage volume nested within the fire suppression storage volume.

**Highland Reservoir**

The City constructed the Highland Reservoir in 2005. This concrete reservoir serves the Highland pressure zone and when necessary, the lower pressure zone via a pressure relief valve in the City’s water transfer station located at the intersection of Highland Drive and 6<sup>th</sup> Avenue.

Table 3-8 indicates reservoir elevations and service pressures for each storage volume component for 2035 for the Highland pressure zone. The table indicates that the City is able to provide more than the minimum 30 psi when OS, ES, SB and FSS are depleted. The City would be able to provide 180,000 gallons of FSS and could still maintain an operating pressure of 30 psi at the highest service.

**TABLE 3-8**

**2035 Storage Analysis – Highland Pressure Zone**

Component	Reservoir Elevation (ft)	High Static Pressure <sup>(1)</sup> (psi)	Low Static Pressure <sup>(2)</sup> (psi)	Storage (gal)		
				Actual	Required	Surplus (+) Deficit (-)
Top of Storage	1259.0	39	121	-	-	-
Operational (OS)	1256.4	37	120	27,000	27,000	-
Equalization (ES)	1256.4	37	120	-	-	-
Fire Suppression (FSS)	1239.0	30	112	180,000	180,000	-
Standby (SB) <sup>(3)</sup>	1239.0	30	112	-	-	-
<b>Total Storage</b>				<b>207,000</b>	<b>207,000</b>	<b>-</b>

- (1) Highest service connection in main pressure zone = 1,170 ft. Estimated from USGS quad sheet with 20-foot contours.
- (2) Lowest service connection in main pressure zone = 980 ft. Estimated from USGS quad sheet with 20-foot contours.
- (3) Standby storage volume nested within the fire suppression storage volume.

**Murray Reservoir (proposed)**

The system pressure in the Murray pressure zone is currently maintained by the Murray BPS, which must run continuously to maintain adequate pressure in the zone. The City plans to build a reservoir for the Murray pressure zone in addition to reconstructing the Murray BPS and constructing a transfer station. This reservoir would be designed to provide adequate fire flows in the Murray area as well as to increase water system reliability should the Murray BPS fail. This reservoir will be served by the new Murray BPS. By constructing this reservoir, the BPS will cycle on and off instead of running continuously, improving system reliability and providing maintenance and power cost savings. The new transfer station will allow the storage volume to supplement flows in the lower pressure zone and thereby increase reliability as well as supplementing necessary FSS for the City. Depending upon the design configuration selected, multiple pressure reducing valves (PRV) will be necessary to allow this single reservoir to serve the various altitudes within the Murray pressure zone. Analysis of the proposed Murray reservoir storage is provided in Table 3-9.

**TABLE 3-9**

**2035 Storage Analysis – Murray Pressure Zone**

Component <sup>(1)</sup>	Reservoir Elevation (ft)	High Static Pressure <sup>(2)</sup> (psi)	Low Static Pressure <sup>(3)</sup> (psi)	Storage (gal)		
				Actual	Required	Surplus (+) Deficit (-)
Top of Storage	1270.0	44	147	-	-	-
Operational (OS)	1267.4	43	146	27,000	27,000	-
Equalization (ES)	1267.4	43	146	-	-	-
Fire Suppression (FSS)	1250.0	35	139	180,000	180,000	-
Standby (SB) <sup>(4)</sup>	1250.0	35	139	-	-	-
<b>Total Storage</b>				<b>207,000</b>	<b>207,000</b>	-

- (1) ERUs for Murray pressure zone of 51 in 2015, 74 in 2021, 180 in 2035, equating to a 6.5 percent growth rate in the Murray pressure zone (50 percent build-out by 2035). Estimated BPS capacity of 400 total gpm. Reservoir bottom slab elevation 1,250 ft.
- (2) Highest service connection elevation in pressure zone = 1,170 ft estimated from USGS quad sheet with 20-foot contours.
- (3) Lowest service connection elevation in pressure zone = 930 ft estimated from USGS quad sheet with 20-foot contours. Pressures would be controlled to be less than 100 psi by PRV(s).
- (4) Standby storage volume nested within fire suppression storage volume.

**BOOSTER PUMPING STATIONS**

The City currently operates two booster pumping stations (BPS) that serve the higher elevations located to the west of the City.

**Murray Booster Pumping Station**

The existing Murray BPS pumps to a closed system. Based on WAC 246-290 and the WSDM, a closed BPS must meet the following requirements.

- 1. The BPS **must** be designed to provide the PHD at 30 psi. It **should** be designed to do so with the largest pump out of service.
- 2. The BPS **must** be designed to provide MDD plus fire flow using fire pumps, domestic pumps, or a combination of the two, while maintaining a 20 psi residual on both the suction and delivery sides of the BPS.

The Murray BPS runs continuously to keep up with water system demands within the closed system. The pressure zone includes a largely residential neighborhood of the City that currently has 51 single-family residential connections. The Murray BPS consists of two-5 HP, 190 gpm pitless pumps with telemetry located on the south side of Murray Street at the low point of the pressure zone. Table 3-10 indicates future anticipated development within the Murray BPS service area.

**TABLE 3-10**

**Murray Pressure Zone Connections 2035 Projection**

<b>Project/Area</b>	<b>Area (ac)</b>	<b>Estimated Density (DU/ac)<sup>(1)</sup></b>	<b>Total Est. Residential Parcels</b>	<b>2035 Est. Residential Connections<sup>(2)</sup></b>
Existing Development	-	-	51	51
Fisher Addition <sup>(3)</sup>	-	-	16	8
Hodgen Short Plats <sup>(3)</sup>	-	-	9	5
Gum Orchards <sup>(4,5)</sup>	20 to 60	2	80	40
West Hills <sup>(4,5)</sup>	20 to 40	1.5	45	23
Vin Mar & Rio Vista <sup>(4,5)</sup>	50	2.0	100	50
<b>Total (rounded)</b>			<b>300</b>	<b>180</b>

- (1) DU/ac = Dwelling Units per acre
- (2) Estimate 50 percent of parcels will have residential structures by 2035.
- (3) Project started and/or substantial interest shown. Projected 0-10 years.
- (4) Project inquired and/or interest indicated. Projected 10-20 years.
- (5) Used the average of areas for estimating connections.

Based on the system demand data presented in Chapter 2 and the hydraulic modeling results presented later in this Plan, the Murray BPS is inadequate to provide MDD plus fire flows in this area without the construction of the new reservoir or upsizing of the existing BPS.

From the discussion preceding Table 2-7, the average water use per ERU is 270 gpd or approximately 49,000 gpd for the projected 180 ERUs in this area. The total production requirement for the Murray BPS, assuming a distribution system leakage percentage of 8 percent for a relatively new distribution system, would be approximately 53,000 gpd (49,000 ÷ 0.92). The ADD, MDD, and PHD for the Murray pressure zone is calculated as follows:

$$\begin{aligned} \text{ADD (Murray Zone)} &= 53,000 \text{ gpd} \div 1,440 \text{ gpm/gpd} = 37 \text{ gpm} \\ \text{MDD (Murray Zone)} &= 2.2 * \text{ADD} = 2.0 * 37 = 81 \text{ gpm} \\ \text{PHD (Murray Zone)} &= 1.8 * \text{MDD} = 1.8 * 81 = 146 \text{ gpm} \end{aligned}$$

The two-5 HP submersible pumps with pitless adapter units (220V, 3-phase) have a combined capacity of 380 gpm, which exceeds the PHD requirement of 146 gpm. The Murray BPS can provide the required PHD of 146 gpm with one pump out of service (single pump capacity is 190 gpm).

The second criterion, MDD plus fire flow, requires a capacity of 1,581 gpm (1,500 gpm residential fire flow requirement and 81 gpm MDD). The Murray BPS is not currently able to meet this requirement. Construction of a new reservoir to serve the Murray pressure zone will resolve this system deficiency. It is anticipated that residential construction in this pressure zone will include homes larger than 3,600 square feet,

requiring a fire suppression storage requirement of 180,000 gallons (2 hours at 1,500 gpm).

Assuming the highest service connection in the Murray residential area is at an approximate elevation of 1,170 feet, the bottom of the proposed Murray Reservoir would need to be located at an elevation of 1,250 or higher to provide approximately 35 psi static pressure at the highest service with OS, ES, SB and FSS depleted. This could be achieved by locating the new reservoir at either the Wood Flat area (approx. elevation 1,250) or East Dry Coulee location (approx. elevation 1,270). It is assumed that the new reservoir will be constructed at the Wood Flat location for the purposes of this Plan.

### **Sunrise Booster Pumping Station**

The Sunrise BPS pumps to an open system (Highland Reservoir). Based on WAC 246-290 and the WSDM, an open system BPS must meet the following requirements.

1. The BPS **must** be designed to provide the MDD for the zone with all pumps in service.
2. It **should** be designed meet the ADD with the largest pump out of service.

The Sunrise BPS pumps to the Highland Reservoir serving the Highland pressure zone. This pressure zone includes the platted residential areas adjacent to the reservoir and a residential neighborhood with a build-out of approximately 550 single-family residences. Water for the booster pump station is taken from the 12-inch feed line to the North Reservoir.

The Highland Reservoir was planned to serve approximately 160 acres with a residential density of 3.5 lots per acre, yielding approximately 550 residences. From the discussion preceding Table 2-7, the average water use for a single-family residence is 270 gpd or approximately 149,000 gpd for the projected 550 ERUs in this area. The total production requirement for the BPS, assuming a distribution system leakage (DSL) percentage of 8 percent for a relatively new distribution system, would be approximately 162,000 gpd ( $149,000 \div 0.92$ ). The ADD, MDD and PHD for the Highland pressure zone are calculated as follows:

$$\begin{aligned} \text{ADD (Highland Zone)} &= 162,000 \text{ gpd} \div 1,440 \text{ gpm/gpd} = 113 \text{ gpm} \\ \text{MDD (Highland Zone)} &= 2.2 * \text{ADD} = 2.2 * 113 = 249 \text{ gpm} \\ \text{PHD (Highland Zone)} &= 1.8 * \text{MDD} = 1.8 * 249 = 448 \text{ gpm} \end{aligned}$$

The two-30 HP submersible pumps with pitless adapter units have a combined capacity of 700 gpm, which exceeds the MDD and PHD flows of 249 gpm and 448 gpm, respectively.

The second criterion, providing ADD (113 gpm) with the largest pump out of service, is met with either one of the two 350 gpm booster pump station pumps running.



The Sunrise BPS is telemetry controlled but does not have an emergency generator or a manual transfer switch for a generator.

## **TRANSMISSION AND DISTRIBUTION**

This section includes a discussion of the hydraulic model calibration and results, and the improvements resulting from the modeling.

### **Hydraulic Capacity Analysis - Modeling**

The Cybernet hydraulic model for the Okanogan water system was converted to H<sub>2</sub>O<sub>N</sub>et for this analysis. Fire flow testing was conducted on June 1, 2015. All wells were turned off, and the transfer station did not open during the testing period. The flow tests produced the following results:

- City Shop (Lower pressure zone) - Field fire flow testing in this area resulted in a residual pressure of 48 psi, corresponding to approximately 880 gpm fire flow capability. Static pressures in this area are approximately 100 psi.
- Cedars Inn (Lower pressure zone) - Field fire flow testing near the Okanogan Inn, off Apple Way Road at hydrant #168, an area located in the lower pressure zone, resulted in a residual pressure of approximately 60 psi. This residual pressure corresponds to a flow rate of approximately 1,600 gpm at the hydrant. This hydrant is located near the end of a 4,800 foot length of 10-inch water main. Static pressures in this area are approximately 85 psi.
- Airport (Lower pressure zone) - Field fire flow testing was performed adjacent to the western entrance to the airport at hydrant #2. Field tests in this area resulted in a residual pressure of 7 psi, corresponding to approximately 500 gpm fire flow capability. The hydrants near the airport are near the end of a 2,400 foot length of 12-inch water main leading to the East Reservoir. Static pressures in this area are approximately 13 psi.
- Murray Street and Hennepin Avenue (Murray pressure zone) - Field fire flow testing was performed at the 980 block of Mill Street. Residual pressure at the hydrant was approximately 18 psi, corresponding to a fire flow capability of approximately 725 gpm. Static pressures in this area are approximately 105 psi, indicating a significant pressure drop when a hydrant is exercised.
- Viewmont Drive (Highland pressure zone) - Field fire flow testing was performed near the residence located at 260 Crestview Drive. Residual pressure at the hydrant was approximately 38 psi, corresponding to a fire

flow capability of approximately 1,050 gpm. Static pressures in this area are approximately 65 psi.

In general, the results of the computer hydraulic model of the City's water system matched the field-measured flows.

The City was hydraulically modeled with the following parameters:

- System-wide demands are equally distributed between the model's 267 demand nodes
- 1,000 gpm fire flow requirement for residential areas
- 1,500 gpm fire flow requirement for commercial and light industrial areas
- Pipe velocities were limited to a maximum of 10 feet per second
- For PHD, both operational and equalization storage depleted, Wells No. 2, 3, 4 and 5 operating
- For MDD, operational, equalization and fire suppression storage depleted, and Wells No. 2, 4 and 5 operating (Well No. 3 is the largest well at 650 gpm is off)

The City's fire flow delivery requirements for particular large structures identified by the Fire Marshall as having specific fire flow needs are not addressed in this Plan. The hydraulic model flow capacities as identified at each particular node are an indication of the flow capacity available to the area via the pipes/proposed pipes serving the hydrants, and not the specific flows withdrawn from the hydrants (see Figures 3-1 and 3-2).

### **Transmission and Distribution Improvements**

The City has developed a schedule of proposed improvements for transmission and distribution improvements which is included in Chapter 8.

There are several residential construction projects which have been started or for which there has been interest shown, which if/when approved or developed, may need to be supplemented by the City's water system within the next ten years. These projects, which are in various stages of development, are listed here with an estimate of the projected lot count. As the timing of these improvements is not currently known, they are not included in this Plan. It will be important to ensure that developer proposals include looping mains that are sized to be at least 8-inches in diameter.

**TABLE 3-11**

**Projects Started and/or Substantial Interest Shown, 0-10 Years**

<b>Project/Area</b>	<b>Description</b>
Chukar Ridge	42 Residential Lots
Sunrise 2nd Addition	14 Residential Lots
Riverwalk	85 Residential Lots with Commercial Area
Sunrise Lower Bench	7 Residential Duplex Lots
Fisher Addition	16 Residential Lots
Hodgen Short Plats	9 Residential Lots
Tribal Social Services	Redevelop the Armory for Emergency Housing
Bellis Property	8 to 12 Residential Lots
Yusi Short Plat	4 Commercial Lots
Sunrise 1st Addition	4 to 6 Residential Lots
Sports Complex	100+ Transient Occupants
Okanogan PUD #1 Office Rebuild	New 30,000 SF Office
Okanogan County VG Admin. Bldg.	Additional 20,000 SF Office

**WATER SYSTEM PHYSICAL CAPACITY ANALYSIS**

Chapter 6 of the WSDM provides methodology for determining the physical capacity of a water system. The basic unit of a system’s service capacity is the ERU. An ERU was defined in Chapter 2 as the average amount of water used by a residential household, or 270 gpd for the City of Okanogan. Historically, DOH has used the physical capacity of a water system (based on the limiting system component) to establish system growth limits for the system. DOH has provided Worksheet 6-1 in the WSDM to summarize the water system physical capacity for source, storage, and water rights. Worksheet 6-1 summarizes the water system physical capacity for source, storage, and water rights.

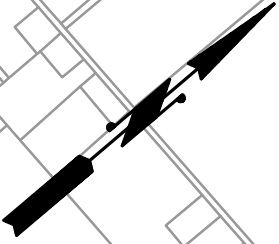
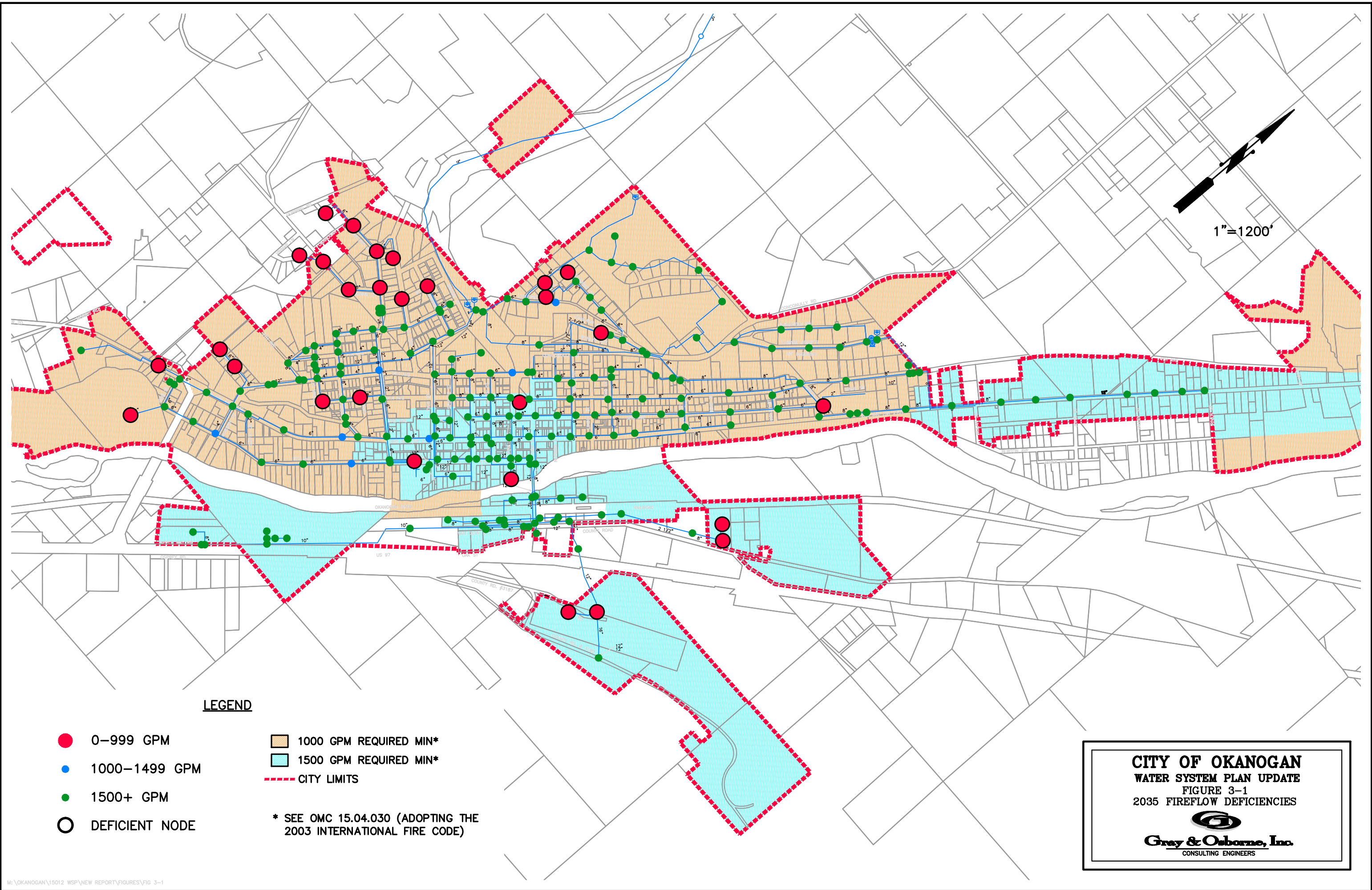

1"=1200'

**LEGEND**

- 0-999 GPM
- 1000-1499 GPM
- 1500+ GPM
- DEFICIENT NODE

- 1000 GPM REQUIRED MIN\*
- 1500 GPM REQUIRED MIN\*
- - - CITY LIMITS

\* SEE OMC 15.04.030 (ADOPTING THE 2003 INTERNATIONAL FIRE CODE)

**CITY OF OKANOGAN**  
**WATER SYSTEM PLAN UPDATE**  
 FIGURE 3-1  
 2035 FIREFLOW DEFICIENCIES



**Gray & Osborne, Inc.**  
 CONSULTING ENGINEERS



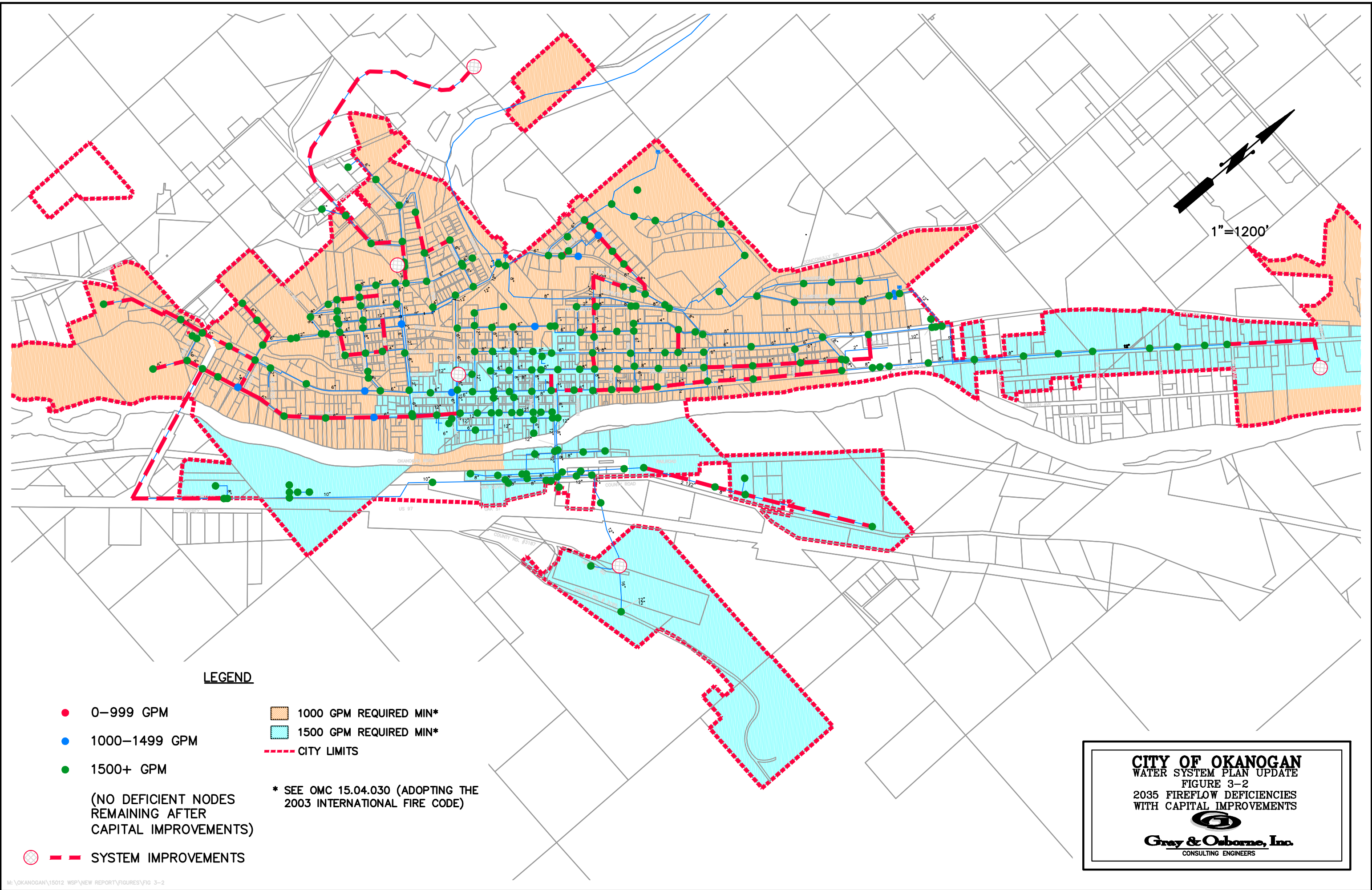

1"=1200'

**LEGEND**

- 0-999 GPM
- 1000-1499 GPM
- 1500+ GPM
- 1000 GPM REQUIRED MIN\*
- 1500 GPM REQUIRED MIN\*
- - - CITY LIMITS

(NO DEFICIENT NODES REMAINING AFTER CAPITAL IMPROVEMENTS)

\* SEE OMC 15.04.030 (ADOPTING THE 2003 INTERNATIONAL FIRE CODE)

⊗ - - - SYSTEM IMPROVEMENTS

**CITY OF OKANOGAN**  
 WATER SYSTEM PLAN UPDATE  
 FIGURE 3-2  
 2035 FIREFLOW DEFICIENCIES  
 WITH CAPITAL IMPROVEMENTS

**Gray & Osborne, Inc.**  
 CONSULTING ENGINEERS

<b>WORKSHEET 6-1: ERU Determinations</b>			
<b>Water System Physical capacity Documentation based on MDD</b>			
<i>Note: Capacity determinations are only for existing facilities that are operational for the water system.</i>			
<b>Specific Single-Family Residential Connection Criteria (measured or estimated demands) (see Chapter 5):</b>			
Average Day Demand (ADD):	270	gpd/ERU	
Max. Day Demand (MDD):	593	gpd/ERU	
<b>Water System Service Connections Correlated to ERUs</b>			
<b>Service Classification</b>	<b>Total MDD for the Classification, gpd</b>	<b>Total # Connections in the Classification</b>	<b>ERUs</b>
<b>Residential</b>			
Single-family	430,000	725	725
Multi-family	98,000	56	165
PFWA	30,000	1	47
<b>Nonresidential</b>			
Commercial	156,000	143	263
Rural	26,000	31	44
School	113,000	10	191
City	129,000	16	217
PFWA	24,000	45	43
Other (specify) <sup>(1)</sup>	---	---	---
<b>DSL</b>	39,000	N/A	66
<b>Other (identify)</b>	---	---	---
<b>Total existing ERUs (Residential + Nonresidential+Non-revenue+other =</b>			<b>1,714</b>
<sup>(1)</sup> Commercial Special Use			
<b>Physical Capacity as ERUs</b>			
<b>Water System Component</b>	<b>Calculated Capacity in ERUs for each component</b>		
Source(s) <sup>(1)</sup>	3,323		
Treatment	N/A		
Equalizing Storage <sup>(3)</sup>	1,973		
Standby Storage <sup>(3)</sup>	1,973		
Distribution	<sup>(2)</sup>		
Transmission	N/A		
Other (specify) <sup>(4)</sup>	13,459		
Other (specify) <sup>(5)</sup>	5,380		
<b>Water System Physical Capacity (ERUs) =</b>		<b>1,973</b>	
<i>(based on the limiting water system component shown above)</i>			
<b>Note: If multiple-day storage is needed to meet MDD, another approach to estimate the ERU capacity is necessary.</b>			
<sup>(1)</sup> Based on Well Nos. 1, 2, 3 and 4 operating 18 hours/day			
<sup>(2)</sup> Distribution system physical capacity varies			
<sup>(3)</sup> Capacity-related storage			
<sup>(4)</sup> Maximum Instantaneous Flow Rate, Qi			
<sup>(5)</sup> Maximum Annual Volume, Qa			

## **OPERATION AND MAINTENANCE ANALYSIS**

Operation and control of the City's water system and the City's preventive maintenance procedures are described in Chapter 6. Other operation and maintenance (O&M) elements, including water quality monitoring, cross connection control, and emergency response are described elsewhere in this Plan. In general, the City's O&M program is satisfactory. The City intends to continue its ongoing program of leak detection and leak repairing in order to reduce DSL.

## **SYSTEM DEFICIENCIES AND PROPOSED IMPROVEMENTS**

A summary of the City of Okanogan's system deficiencies and proposed improvements is presented in Table 3-12. A comprehensive description of proposed improvements including costs is presented in Chapter 9: Capital Improvement Financing.

**TABLE 3-12**

**Summary of System Deficiencies and Proposed Improvements**

<b>SYSTEM DEFICIENCY</b>	<b>PROPOSED IMPROVEMENT</b>	<b>SCHEDULE</b>
<b>Water Rights</b>		
The City has sufficient instantaneous and annual withdrawal water rights to meet its 6-year and 20-year demands.	Consolidate water rights; review and coordinate water rights applications for areas east of the Okanogan River with the Confederated Tribes of the Colville Reservation.	6-year
<b>Source Protection</b>		
The City is in compliance with source protection, i.e., wellhead protection requirements, except for protective covenants for each of the City's wells.	Pursue protective covenants for the City's wells.	6-year
<b>Telemetry</b>		
Outdated telemetry system.	Upgrade the City's telemetry system with a new computer, software (HMI) and programmable logic controller at the master station to increase flexibility, control and reliability.	6-year
<b>Source Improvements</b>		
City seeks feasibility study to place Watercress Springs source back into service.	Feasibility study to investigate requirements to rehabilitate the Watercress Springs source, storage, and distribution system	6-year
No standby generator availability for the City's sources.	Provide portable standby generator and provide all active wells with motor soft starts and automatic transfer switches.	
Abandoned well need to be decommissioned in accordance with Ecology requirements.	Decommission old Well Nos. 1 and 4, and well located at the Okanogan Sports Complex.	
Well No. 3 has experienced loss of production in recent years.	Perform downhole video inspection of Well No. 3.	
City seeks bypass pipe at Well No. 4.	Provide bypass piping at Well No. 4.	
City seeks to investigate possible new source in north Okanogan.	Well No. 6 (Riverwalk Well) investigation and development.	20-year



**TABLE 3-12 (cont.)**

**Summary of System Deficiencies and Proposed Improvements**

<b>SYSTEM DEFICIENCY</b>	<b>PROPOSED IMPROVEMENT</b>	<b>SCHEDULE</b>
<b>Treatment</b>		
Disposal of arsenic treatment facility sludge at the wastewater treatment plant no longer an acceptable option.	Feasibility study to investigate alternatives for the collection and disposal of arsenic-laced sludge from the arsenic treatment facility.	6-year
	Construct sludge collection and disposal facilities in accordance with the findings of the feasibility study.	
Occasional failed bacteriological tests.	Install chlorination facilities at the City's sources.	20-year
<b>Storage</b>		
Low pressures and lack of fire suppression in the Murray pressure zone.	Construct 200,000-gallon Murray Reservoir, transfer station, and pressure-reducing valves, and transmission pipeline.	20-year
West Reservoir Nos. 1 and 2 have inadequate site security and the West Reservoir No. 1 roof needs to be replaced.	Install security fencing and gates at the reservoir site and replace the existing wood-framed truss roof.	20-year
Inadequate mixing in the East Reservoir.	Clean reservoir and reconfigure reservoir fill piping.	20-year
<b>Distribution System</b>		
New vault needed for the existing Murray Street master meter.	Demolish the existing building and install new vault for the master meter.	6-year
New booster pumps, electrical and control equipment needed to serve the future Murray Street reservoir.	Construct new Murray Street booster pump station capable of serving the future Murray Street reservoir.	

**TABLE 3-12 (cont.)**

**Summary of System Deficiencies and Proposed Improvements**

<b>SYSTEM DEFICIENCY</b>	<b>PROPOSED IMPROVEMENT</b>	<b>SCHEDULE</b>
<b>Distribution System con't</b>		
Inadequately sized and distribution system piping.	Distribution system improvements, to include increasing fire flows by looping or upsizing water lines, and replacing existing AC and steel piping with new piping. Proposed improvements identified in Chapter 8.	6-year & 20-year
Old AC and steel distribution system piping.		
<b>Operation and Maintenance</b>		
Valves and water lines.	Locate and exercise valves and flush water distribution lines.	On-going
<b>Miscellaneous</b>		
Consolidation feasibility study.	Feasibility study to investigate consolidation of the Way S Group A water system into the City's water system.	2016

**Notice of Public Hearing**  
**Water Use Efficiency Goal Setting**

In accordance with WAC 246-290-830, on Tuesday, February 16<sup>th</sup>, 2016 during their regular meeting, the City Council of the City of Okanogan will hold a public hearing to provide an opportunity for the public to participate and comment on the City's water use efficiency goals; these goals once established will be used in the management and operation of the City's water system. This meeting is to begin at 7:00 p.m. in the Council Chamber Room, City Hall, 120 3rd Avenue, North, Okanogan, Washington, please consult the agenda as to what order of business the hearing is. All persons interested in providing comment are encouraged to be present to be heard during the hearing.

Persons desiring to provide written comments on the subject must file said comments at the Clerk's Office no later than 4:00 p.m. February 16<sup>th</sup>, 2016 or at the hearing.

**MORE INFORMATION:** The complete project file consisting of the draft update of the water system plan, material supporting the rationale for the proposed efficiency goals, maps, and related environmental documents, are available to the public for review, please contact the Clerk's Office, City Hall, (509) 422-3600 during normal business hours or by visiting the City's website at [www.okanogancity.com](http://www.okanogancity.com) and following the Public Notice links.

**CITY OF OKANOGAN  
COUNCIL MINUTES  
February 16, 2016**

**CALL TO ORDER**

The Regular Meeting of the Okanogan City Council was called to order by Mayor Culp at 7:00 p.m. and all stood for the Pledge of Allegiance.

The following were:

Present: Mayor Jon Culp      Councilmembers: Lisa Bauer, Kristina McIntosh, Jerry Paul, Patricia Stanton, Wayne Turner, and Janet Wilson.

Also Present: Clerk Treasurer Craig Attwood, Deputy Clerk Treasurer Susan Skirko-Stewart, Director of Public Works Shawn Davisson, and Dave Ellis of Gray & Osborne, Inc.

**PUBLIC HEARING**

*Water Use Efficiency Goal Setting*

Mayor Culp opened the Public Hearing on the Proposed Water Use Efficiency Goals at 7:01 p.m.

Mayor Culp stated the purpose of the Hearing is to take relevant testimony on the City's proposed water use efficiency goals to be used in the management and operation of the City's water system.

Mayor Culp opened the testimony portion of the hearing at 7:01 p.m. and invited anyone present to provide testimony. There was none presented.

Mayor Culp provided the opportunity for engineering and staff reports.

Mayor Culp provided the opportunity for the members of the Council to ask questions. There were none presented.

Mayor Culp provided for discussion amongst the Council. There were none presented.

Mayor Culp closed the Public Hearing portion of the meeting at 7:02 p.m.

**APPROVAL OF AGENDA AND CONSENT AGENDA**

Mayor Culp asked if there were any alterations to the Agenda or Consent Agenda. Turner moved, seconded by Paul to approve the Agenda and Consent

Agenda as presented. Mayor Culp asked if there were any objections to the motion. Seeing no objection raised, the motion passed without objection.

### **EXCUSE COUNCILMEMBERS**

Councilmember Denise Varner was excused with passage of the Agenda and Consent Agenda.

### **APPROVAL OF MINUTES**

The Minutes of the Regularly Scheduled Council Meeting of February 2, 2016 were approved with passage of the Consent Agenda.

### **APPROVAL OF VOUCHERS**

Claims Vouchers numbered 42089 through 42126 dated February 16, 2016 in the amount of \$56,975.77, and a debit card transaction dated February 1, 2016 in the amount of \$18.00 were approved with the Consent Agenda.

### **PUBLIC COMMENT**

Mayor Culp opened the floor for Public Comment. Seeing none offered, Public Comment was closed.

### **DEPARTMENT HEAD REPORTS**

Director of Public Works Davisson submitted a written report. In addition he announced the following:

- Performed street sweeping
- Performed trimming trees in alley ways
- Performed fire truck repairs
- Public Works held monthly safety meeting
- Public Works participated in a Wellness Committee Meeting

Fire Chief Gavin submitted a written report, but was not present at the meeting.

Clerk's Office submitted a written report and reviewed the information in his report. In addition he announced the following:

- ❖ Introduced Dave Ellis of Gray & Osborne, Inc. whose firm is working on the Water System update and efficiency goals

Okanogan County Sheriff's Office submitted a written report, but was not present at the meeting.

Building Official Johnson submitted a written report, but was not present at the meeting.

### **COMMITTEE REPORTS**

There were no Committee Reports on the Agenda.

### **UNFINISHED BUSINESS**

There was no Unfinished Business on the Agenda.

### **NEW BUSINESS**

#### Water Use Efficiency Goals

Mayor Culp introduced Mr. Dave Ellis of Gray & Osborne, Inc. who presented a power point presentation outlining the City of Okanogan Water Use Efficiency Goals.

Mr. Ellis reviewed the Municipal Water Law of 2003, which established that all municipal water suppliers must use water more efficiently. In addition, Mr. Ellis pointed out in 2007 the law directed the Department of Health to develop water use efficiency program.

Mr. Ellis announced the City of Okanogan's new WUE goals (listed in Chapter 4 on page 4-3) are:

- ❖ **Supply side goal:** Reduce system leakage to 8% or less (three-year average) by 2021.
- ❖ **Demand side goal:** Reduce per capita consumption by 3% by 2021.

Turner moved, seconded by Stanton to adopt the goals established in Chapter 4 of the Water Use Efficiency Program.

There was a brief discussion.

Ayes: Bauer, Paul, Turner, Wilson, Stanton, and McIntosh

Noes: None

Motion carried: 6 Ayes: 0 Noes

### **PUBLIC COMMENT**

Mayor Culp opened the floor and invited Public Comment. Seeing none offered, Public Comment was closed.



**COUNCILMEMBER'S COMMENT**

Wilson stated more information regarding the sales tax revenue relating to cannabis sales is available at: "502data.com"

Wilson announced the Thompson Okanagan Tourism/Economic Development District intends on updating their website and are looking for funding support to assist with the update. For more information regarding travel along the Highway 97 corridor visit: "route97.net"

**MAYOR'S REPORT**

Mayor Culp announced he intends to schedule interviews for the Code Enforcement/Animal Control Officer soon.

**ADJOURNMENT**

There being no further business before the Council, the Meeting was adjourned at 8:13 p.m.

Minutes taken and prepared by Deputy Clerk Treasurer Susan Skirko-Stewart

**APPROVED:**



---

**Jon K Culp, Mayor**

**ATTEST:**



---

**Craig Attwood, Clerk Treasurer**

# CHAPTER 4

## WATER USE EFFICIENCY

### BACKGROUND

In 2003, the Washington State Legislature passed Engrossed Second Substitute House Bill 1338, which has come to be known as the 2003 Municipal Water Law. Among other things, the new law required the Washington State Department of Health (DOH) to develop a rule that defines how municipalities are to demonstrate efficient use of their water supplies. In response, DOH developed the Water Use Efficiency (WUE) Rule, which became effective on January 22, 2007. Key elements of the rule and the City of Okanogan’s progress in meeting the rule are summarized in Table 4-1.

**TABLE 4-1**  
**Summary of Water Use Efficiency Rule Requirements**

Requirement	Deadline <sup>(1)</sup>	Status - City of Okanogan
Include WUE program in planning documents	January 22, 2008	Completed
Submit service meter installation schedule	July 1, 2008	All Meters Installed
Submit first annual performance report	July 1, 2008	On-going Annually <sup>(2)</sup>
Set WUE goals through a public process	July 1, 2009	Completed
Meet distribution leakage standard (based on 3-year rolling average)	July 1, 2010, or 3 years after installing all service meters	In Progress
Complete installation of all service meters	January 22, 2017	Completed

(1) These are the deadlines for municipalities with > 1,000 connections. Deadlines are generally later for smaller municipalities.

(2) A copy of the most recent report is included at the end of this chapter.



## **PRODUCTION AND SOURCE METERS**

The City's water supply is provided by four wells, Well Nos. 2, 3, 4, and 5. Each well is equipped with a source meter. The City calibrates and maintains each source meter as needed. Further description of the City's wells is provided in Chapter 1.

Monthly water production from the City's wells for 2009 through 2014 are shown in Figure 2-2. Annual production data, including average day and maximum day demands are summarized in Tables 2-2 and 2-3. Water demand forecasts for the 6- and 20-year planning periods are provided in Tables 2-11 and 2-12.

## **SERVICE METERS AND WATER CONSUMPTION**

Meters are required upon hookup and all of the City's residential and commercial customers are metered. The City performs maintenance and replacement on service meters as needed.

## **INTERTIES**

The City wholesales water to the Progressive Flats Water Association (PFWA). The Agreement between the City and the PFWA is contained in Appendix M.

## **WATER USE EFFICIENCY PROGRAM**

In January 2011, DOH published the third edition of its Water Use Efficiency Guidebook (Guidebook). Section 5.3 of the Guidebook summarizes the items that are to be included in a WUE program. A discussion of each item is provided in this section.

## **CURRENT WATER USE EFFICIENCY PROGRAM**

The City's current WUE program consists of the following:

- Program Promotion: The City makes DOH water conservation flyers available at City Hall and encourages water conservation in its Consumer Confidence Report.
- Source Meters: The City's active wells are equipped with source meters. Data is collected and saved at the waste water treatment facility by the City's telemetry system.
- Service Meters: All of the City's residential, commercial, and industrial water customers are metered.
- Rate Structure: The City has adopted conservation rates that consist of a base rate and volume charge.
- Distribution System Leakage: The City has maintained its DSL to less than 16 percent since 2010, with the 2014 three-year average DSL coming down to just over 10 percent.

The City has almost succeeded in reducing DSL to the DOH three-year average requirement of 10 percent or less. To continue working toward that goal, the City’s Water Loss Control Action Plan is presented later in the chapter.

**NEW WUE GOALS**

The WUE rule requires a water system’s elected governing body to establish WUE goals that are measurable and have a timeframe for implementation. Okanogan’s new WUE goals are:

- **Supply side goal:** Reduce system leakage to 8 percent or less (three-year average) by 2021.
- **Demand side goal:** Reduce per capita consumption by 3 percent by 2021.

These goals were voted on at the City’s council meeting on February 16, 2016. A copy of the minutes from that meeting is provided at the end of this chapter.

**WUE MEASURES**

The WUE Rule requires all municipal water systems to implement and evaluate certain mandatory water use efficiency measures. The City is also required to identify additional demand (i.e., customer) side measures. The purpose of adopting a particular set of water use efficiency measures is to develop a strategy to meet the City’s water use efficiency goals. The mandatory measures the City is required to address are summarized in Table 4-2.

**TABLE 4-2**

**Mandatory Water Use Efficiency Measures**

<b>Mandatory Measures</b>	<b>Requirement</b>	<b>Status</b>
Install source meters	Implementation	Completed
Install service meters	Implementation	Completed
Calibrate meters per industry standards	Implementation	As Needed Based on Readings
Water loss control action plan if DSL>10%	Implementation	In Progress
Educate customers about WUE once per year	Implementation	On-going Every Year
Water conservation rates	Evaluation	Evaluated Regularly

In addition to these mandatory measures, WAC 246-290-810 (4)(d) requires systems with more than 1,000 connections and less than 2,499 connections to adopt another five demand (i.e. customer) side water use efficiency measures. The Guidebook provides that a qualified WUE measure that is implemented for different customer classes counts as multiple WUE measures.

The City has determined that implementing these measures will be cost effective, and plans to pay for these measures using operating funds. The City believes these measures, in addition to ongoing efforts to educate its customers about water use efficiency, will enable it to meet its second WUE goal of reducing per capita consumption by 3 percent by 2021. Table 4-3 summarizes the demand-side water use efficiency measures the City plans to implement over the next six years.

**TABLE 4-3**

**Demand-Side Water Use Efficiency Measures**

<b>Demand-Side Measures</b>	<b>Customer Classes Affected</b>	<b>Number of Measures <sup>(1)</sup></b>	<b>Estimated Annual Water Savings <sup>(2)</sup></b>	<b>Status</b>	<b>Cost</b>
Notify customers of high meter reads	All <sup>(3)</sup>	3	3%	On-going	Minimal
Consumption history on water bill	All <sup>(3)</sup>	3		On-going	Minimal
<b>Total Measures (5 required)</b>		<b>6</b>	-	-	-

- (1) Per the Guidebook, if a qualified WUE measure is implemented for different customer classes, it counts as multiple WUE measures (up to three customer classes).
- (2) Savings projected by the end of the 6-year planning period. Savings are expected to enable the City to meet its goal, i.e., to reduce per capita consumption by 3 percent by 2021.
- (3) Single Family Residential, Multi-Family Residential, Commercial, Schools and Rural.

**WUE EDUCATION**

The City encourages water use efficiency by distributing newsletters containing water saving ideas to its customers annually with its consumer confidence report. Water conservation flyers are also available at City Hall.

**EVALUATING WUE EFFECTIVENESS**

The City plans to track the effectiveness of its WUE efforts by annually checking its distribution system leakage to determine whether its on-going leak detection and repair efforts are enabling it to meet its first goal of reducing its DSL three-year average to 8

percent or less. It also plans to measure reductions in summer water use, park use, and leaks, while maintaining a conservation rate structure to incentivize water conservation.

Table 4-4 shows how meeting the City’s water use efficiency goals would affect its projected water demands. The water savings shown in the table are due to meeting its demand side goal of reducing its per capita consumption by 3 percent and meeting its supply side goal of 8 percent or less DSL since the three-year average is currently at just over 10 percent for 2014. The City estimates the most significant savings will come from reducing DSL, and the remainder will come from the demand-side measures.

**TABLE 4-4**  
**Projected Water Demands with Water Savings<sup>(1)</sup>**

Year	Population	ERUs	ADD (gpd)	Annual Prod. (af/yr)	MDD (gpd)	MDD (gpm)	PHD (gpm)
<b>Without Savings<sup>(2)</sup></b>							
2015	2,742	1,700	563,000	630	1,239,000	860	1,508
2021	2,811	1,743	577,000	650	1,269,000	880	1,543
2035	2,980	1,848	612,000	690	1,346,000	930	1,630
<b>With Savings<sup>(3)</sup></b>							
2015	2,742	1,700	563,000	630	1,239,000	860	1,508
2021	2,811	1,743	558,000	630	1,228,000	850	1,490
2035	2,980	1,848	593,000	660	1,305,000	910	1,595
<b>Net Savings</b>							
2015	2,742	1,700	0	0	0	0	0
2021	2,811	1,743	19,000	20	41,000	30	53
2035	2,980	1,848	19,000	30	41,000	20	35

- (1) Savings attributable to reducing DSL to 8 percent and reducing per capita consumption by 3 percent over 6 years.
- (2) From Table 2-10.
- (3) From Table 2-11.

**DISTRIBUTION SYSTEM LEAKAGE**

Current DOH rules require calculation of the three-year average DSL to determine compliance with its maximum 10 percent DSL allowance. The analysis of the City’s DSL presented in Chapter 2 indicates the City’s 2012-2014 three-year average DSL was approximately 10 percent (Table 2-6). As indicated above, the City’s first WUE goal is to reduce DSL to 8 percent or less which it believes is achievable if it targets system leakage more aggressively.

## **WATER LOSS CONTROL ACTION PLAN**

Because the City's three-year average DSL is slightly greater than 10 percent (10.4%) and less than 20 percent, WAC 246-290-820(4) requires the City to prepare a water loss control action plan.

The water loss control action plan must include control methods to achieve compliance with the DSL standard; an implementation schedule; a budget that demonstrates how the control methods will be funded, and an assessment of data accuracy and data collection. The water loss control action plan elements are addressed herein.

### ***Control Methods***

The City's capital improvement plan includes the replacement of numerous old water lines located throughout the City. These improvement projects will also include the replacement of old water meters. It is anticipated that these projects will reduce distribution system leakage through the installation of accurate water meters and the replacement of old water lines that may be compromised due to being past their useful life.

The City performs leak detection surveys every three years in accordance with the operations and maintenance schedule shown in Table 6-3.

### ***Implementation Schedule***

The implementation schedule of the City's control methods, which includes water line and meter replacements, is shown in the distribution section of Table 8-1 of the City's capital improvement plan. Leak detection surveys occur every three years.

It is anticipated that the City's 3-year distribution system leakage, currently at 10.4 percent for 2014, will decrease below the 10 percent maximum allowable by the end of 2016 after completion of the City's 5<sup>th</sup> Avenue Water Main Replacement project.

### ***Budget***

Budgeting for the water line and meter replacement projects are shown in the City's 6-year financing plan in Table 9-9.

### ***Technical or Economic Concerns***

The City has no technical concerns in meeting the distribution leakage standard. The City anticipates the need for grants and/or loan funding in order to complete the distribution system improvements projects shown in the City's capital improvement plan.

**Data Accuracy and Collection Assessment**

Service meter accuracy generally decreases with time in service. In order to achieve a more accurate accounting of water consumption, the City checks service meter calibration of older meters and repairs or replaces old meter as needed. The City also check all source meters annually for proper function in accordance with the operations and maintenance schedule shown in Table 6-3.

Over the past several years the City has improved its identification of all water uses, including authorized unmetered consumption, in order to more accurately assess water consumption throughout the City. The City plans to continue these efforts.

**CONSERVATION RATE STRUCTURE**

The City currently has a base rate plus uniform block rate structure. It charges different rates based on customer class and whether or not they are in or out of the city limits. But rates do not change for different meter sizes. Although the City charges customers for every gallon used, which promotes water conservation, the City is required to evaluate either an inclining block or seasonal rate structure.

**Inclined Block Rate Structure Evaluation**

The City has evaluated the feasibility of adopting and implementing an inclined block rate structure. Doing so could further reduce excess water use during the summer months when lawn irrigation is high. The pros and cons of adopting an inclined block rate structure are shown in Table 4-5.

**TABLE 4-5**

**Inclined Block Rate Structure Pros and Cons**

<b>Pros</b>	<b>Cons</b>
Only those customers who use more water pay the higher rate.	Could result in drastic increase in monthly bill for current high use consumers.
Premium cost charge for higher usage could be used for infrastructure improvements.	Could be difficult to apply to commercial customers due to wide range of commercial usage.
Promotes water conservation due to increasing cost with higher usage.	Could result in lost revenues in difficult economic times as customers seek to curtail spending.

Increased revenues possible from an inclined block rate structure could help fund required water system improvements as well as operations and maintenance costs to keep the system in good working order.

## **WATER RECLAMATION**

The City's wastewater is treated at the City of Okanogan Wastewater Treatment Facility. Per WAC 246-290-100(4)(f)(vii), City's with more than 1,000 connections are required to evaluate opportunities for use of reclaimed water. In 2008, the City evaluated the feasibility of converting the wastewater treatment plant to a Water Reclamation Facility but determined that it is not economically feasible. The City has decided not to pursue water reclamation for the following reasons:

- The City has sufficient water rights beyond the 20-year planning period.
- The City has determined it is not economically feasible.
- The City currently has sufficient source capacity for its water system.

## **WATER SUPPLY CHARACTERISTICS**

Okanogan's water supply characteristics are summarized as follows:

- **Name and Location** - The City's water supply consists of four active wells known as Well Nos. 2, 3, 4 and 5. A map of the wells and the City's water system is provided on Figure 1-1. Additional description of the City's sources is provided in Chapter 1.
- **Capacity and Seasonal Limitations** - Well No. 2 is capable of producing 200 gpm, Well No. 3 is capable of producing 650 gpm, Well No. 4 is capable of producing 550 gpm, and Well No. 5 is capable of producing 425 gpm. These wells adequately meet the City's water needs. Well No. 5 is limited when the Okanogan River is below the minimum flows identified in the water right authorization.
- **Water Rights** - The City has sufficient water rights to serve its existing population, and has a surplus that is sufficient to meet 20-year demands. Additional discussion of the City's water rights is provided in Chapters 1 and 3. The City's water right self-assessment form is provided in Table 3-4. Pertinent water right documentation is provided in Appendix K.
- **Legal Constraints** - There are currently no legal constraints that would affect the City's ability to supply water to its customers over the next 20 years.
- **Groundwater Source** - Groundwater withdrawals from the City's four wells indicate good water quality, except for Well No. 4, which has high arsenic levels. Groundwater withdrawn from Well No. 4 is treated at the City's arsenic treatment facility prior to entry into the City's water distribution system. The City does not provide chlorination for

disinfection of its groundwater sources. The City continues to perform water quality testing as required by the Department of Health.

- The quantity of groundwater withdrawal is currently sufficient for the City's needs. The effect of continual groundwater withdrawal on water quality and quantity into the future is unknown. The City plans to install ports at each wellhead to facilitate groundwater level measurements as part of its capital improvement plan. These measurements will allow for monitoring of groundwater aquifer levels at each well over time and provide a simple assessment of quantity for the City.

In general, the City has adequate source capacity and water rights, and does not foresee any obstacles that would prevent it from continuing to provide a safe, reliable, and affordable water supply to its customers for the 20-year planning period.



**Notice of Public Hearing**  
**Water Use Efficiency Goal Setting**

In accordance with WAC 246-290-830, on Tuesday, February 16<sup>th</sup>, 2016 during their regular meeting, the City Council of the City of Okanogan will hold a public hearing to provide an opportunity for the public to participate and comment on the City's water use efficiency goals; these goals once established will be used in the management and operation of the City's water system. This meeting is to begin at 7:00 p.m. in the Council Chamber Room, City Hall, 120 3rd Avenue, North, Okanogan, Washington, please consult the agenda as to what order of business the hearing is. All persons interested in providing comment are encouraged to be present to be heard during the hearing.

Persons desiring to provide written comments on the subject must file said comments at the Clerk's Office no later than 4:00 p.m. February 16<sup>th</sup>, 2016 or at the hearing.

**MORE INFORMATION:** The complete project file consisting of the draft update of the water system plan, material supporting the rationale for the proposed efficiency goals, maps, and related environmental documents, are available to the public for review, please contact the Clerk's Office, City Hall, (509) 422-3600 during normal business hours or by visiting the City's website at [www.okanogancity.com](http://www.okanogancity.com) and following the Public Notice links.

**CITY OF OKANOGAN  
COUNCIL MINUTES  
February 16, 2016**

**CALL TO ORDER**

The Regular Meeting of the Okanogan City Council was called to order by Mayor Culp at 7:00 p.m. and all stood for the Pledge of Allegiance.

The following were:

Present: Mayor Jon Culp      Councilmembers: Lisa Bauer, Kristina McIntosh, Jerry Paul, Patricia Stanton, Wayne Turner, and Janet Wilson.

Also Present: Clerk Treasurer Craig Attwood, Deputy Clerk Treasurer Susan Skirko-Stewart, Director of Public Works Shawn Davisson, and Dave Ellis of Gray & Osborne, Inc.

**PUBLIC HEARING**

*Water Use Efficiency Goal Setting*

Mayor Culp opened the Public Hearing on the Proposed Water Use Efficiency Goals at 7:01 p.m.

Mayor Culp stated the purpose of the Hearing is to take relevant testimony on the City's proposed water use efficiency goals to be used in the management and operation of the City's water system.

Mayor Culp opened the testimony portion of the hearing at 7:01 p.m. and invited anyone present to provide testimony. There was none presented.

Mayor Culp provided the opportunity for engineering and staff reports.

Mayor Culp provided the opportunity for the members of the Council to ask questions. There were none presented.

Mayor Culp provided for discussion amongst the Council. There were none presented.

Mayor Culp closed the Public Hearing portion of the meeting at 7:02 p.m.

**APPROVAL OF AGENDA AND CONSENT AGENDA**

Mayor Culp asked if there were any alterations to the Agenda or Consent Agenda. Turner moved, seconded by Paul to approve the Agenda and Consent

Agenda as presented. Mayor Culp asked if there were any objections to the motion. Seeing no objection raised, the motion passed without objection.

### **EXCUSE COUNCILMEMBERS**

Councilmember Denise Varner was excused with passage of the Agenda and Consent Agenda.

### **APPROVAL OF MINUTES**

The Minutes of the Regularly Scheduled Council Meeting of February 2, 2016 were approved with passage of the Consent Agenda.

### **APPROVAL OF VOUCHERS**

Claims Vouchers numbered 42089 through 42126 dated February 16, 2016 in the amount of \$56,975.77, and a debit card transaction dated February 1, 2016 in the amount of \$18.00 were approved with the Consent Agenda.

### **PUBLIC COMMENT**

Mayor Culp opened the floor for Public Comment. Seeing none offered, Public Comment was closed.

### **DEPARTMENT HEAD REPORTS**

Director of Public Works Davisson submitted a written report. In addition he announced the following:

- Performed street sweeping
- Performed trimming trees in alley ways
- Performed fire truck repairs
- Public Works held monthly safety meeting
- Public Works participated in a Wellness Committee Meeting

Fire Chief Gavin submitted a written report, but was not present at the meeting.

Clerk's Office submitted a written report and reviewed the information in his report. In addition he announced the following:

- ❖ Introduced Dave Ellis of Gray & Osborne, Inc. whose firm is working on the Water System update and efficiency goals

Okanogan County Sheriff's Office submitted a written report, but was not present at the meeting.

Building Official Johnson submitted a written report, but was not present at the meeting.

### **COMMITTEE REPORTS**

There were no Committee Reports on the Agenda.

### **UNFINISHED BUSINESS**

There was no Unfinished Business on the Agenda.

### **NEW BUSINESS**

#### Water Use Efficiency Goals

Mayor Culp introduced Mr. Dave Ellis of Gray & Osborne, Inc. who presented a power point presentation outlining the City of Okanogan Water Use Efficiency Goals.

Mr. Ellis reviewed the Municipal Water Law of 2003, which established that all municipal water suppliers must use water more efficiently. In addition, Mr. Ellis pointed out in 2007 the law directed the Department of Health to develop water use efficiency program.

Mr. Ellis announced the City of Okanogan's new WUE goals (listed in Chapter 4 on page 4-3) are:

- ❖ **Supply side goal:** Reduce system leakage to 8% or less (three-year average) by 2021.
- ❖ **Demand side goal:** Reduce per capita consumption by 3% by 2021.

Turner moved, seconded by Stanton to adopt the goals established in Chapter 4 of the Water Use Efficiency Program.

There was a brief discussion.

Ayes: Bauer, Paul, Turner, Wilson, Stanton, and McIntosh

Noes: None

Motion carried: 6 Ayes: 0 Noes

### **PUBLIC COMMENT**

Mayor Culp opened the floor and invited Public Comment. Seeing none offered, Public Comment was closed.



**COUNCILMEMBER'S COMMENT**

Wilson stated more information regarding the sales tax revenue relating to cannabis sales is available at: "502data.com"

Wilson announced the Thompson Okanagan Tourism/Economic Development District intends on updating their website and are looking for funding support to assist with the update. For more information regarding travel along the Highway 97 corridor visit: "route97.net"

**MAYOR'S REPORT**

Mayor Culp announced he intends to schedule interviews for the Code Enforcement/Animal Control Officer soon.

**ADJOURNMENT**

There being no further business before the Council, the Meeting was adjourned at 8:13 p.m.

Minutes taken and prepared by Deputy Clerk Treasurer Susan Skirko-Stewart

**APPROVED:**

  
\_\_\_\_\_  
**Jon K Culp, Mayor**

**ATTEST:**

  
\_\_\_\_\_  
**Craig Attwood, Clerk Treasurer**

## **CHAPTER 5**

### **SOURCE WATER PROTECTION**

#### **GENERAL**

This chapter presents the Wellhead Protection Program for the City of Okanogan.

#### **OBJECTIVE**

Water from underground aquifers, commonly referred to as groundwater, forms the primary source of drinking water for approximately 65 percent of Washington State residents. The City of Okanogan relies on groundwater wells to meet its water supply needs. To protect groundwater supplies, the Environmental Protection Agency (EPA) and Washington Department of Health (DOH) require public water utilities to develop a wellhead protection program as a component of its water system plan. The purpose of a wellhead protection program is to provide water systems with a proactive program for preventing groundwater contamination. The minimum requirements for a wellhead protection plan are specified in WAC 246-290-135(3).

#### **WELLHEAD PROTECTION AREA DELINEATIONS**

##### **DEFINITION OF A WELLHEAD PROTECTION AREA**

A wellhead protection area (WHPA) is defined as the surface and subsurface area surrounding a well that supplies a public water system through which contaminants are likely to pass and eventually reach the well (DOH, 1995). In Washington, WHPAs are based on time-of-travel criteria, or the theoretical distance a particle of water travels in a prescribed period of time. At a minimum, the DOH requires communities to look at the following five WHPAs:

- Sanitary control area
- 6-month time-of-travel WHPA
- 1-year time-of-travel WHPA
- 5-year time-of-travel WHPA
- 10-year time-of-travel WHPA

A discussion of the WHPAs is provided in the following sections.

##### **Sanitary Control Area**

The sanitary control area is the protective area around the wellhead as required by WAC 246-290-135. According to this statute, the minimum sanitary control area for wells is 100 feet, unless engineering justification supports a smaller area. Conversely, DOH may

require a larger sanitary control area if geological and hydrological data support such a decision.

### **Time-of-Travel WHPAs**

The time-of-travel WHPAs are determined by estimating the travel distance of a hypothetical particle of water traveling through the aquifer to a pumping well for a selected travel time, (e.g., 1-year). The WHPAs define aquifer management regions around the well that can be used to identify and control potential sources of contamination. The management of WHPAs is often done incrementally with the most aggressive management strategies being applied in the 6-month and 1-year WHPAs.

Time-of-travel WHPAs are based on several assumptions. First, time-of-travel criteria do not consider vertical movement of water or contaminants from the land surface to the screened interval of the well. Therefore, time-of-travel zones tend to be inherently conservative. Also, it is assumed that contaminants move at the same rate as water in the subsurface, where actual contaminants may move slower or faster than water. This assumption is also typically conservative because the soil matrix, biological processes, and chemical processes tend to retard the transport of contaminants in the subsurface.

Time-of-travel criteria may not be applicable in every situation. DOH notes that in some areas of the state, time-of-travel criteria may not be appropriate if the capture zone is recharged in less than 10 years, if complicated geographic features are present, or if a significant contribution to the well is from a nearby surface source. In these settings, alternate WHPA delineation criteria may be used with DOH approval. While the Okanogan River has been shown to influence the City's wells, the City feels that time-of-travel criteria are appropriate for its wells at this time.

#### Six-Month Time-of-Travel Zone

The six-month time-of-travel zone represents the surface area overlying the portion of aquifer supplying water to the well within a six-month period. Aggressive management strategies are recommended in the six-month time-of-travel zone because of the limited time a purveyor can respond to contamination in this zone. The six-month time-of-travel zone is vulnerable to both microbial and chemical contamination. EPA literature suggests that bacteria and viruses survive less than one year in groundwater, so potential sources of microbial contamination should be monitored carefully. Similarly, limited response times for mitigation actions following chemical contamination require aggressive control of potential sources of chemical contamination within this zone.

#### One-Year Time-of-Travel Zone

The one-year time-of-travel zone represents the surface area overlying the portion of aquifer supplying water to the well within a one-year period. As in the six-month time-of-travel zone, the susceptibility of the one-year time-of-travel zone to both microbial and chemical contamination requires aggressive controls of potential contamination sources.

### Five-Year Time-of-Travel Zone

The five-year time-of-travel zone represents the surface area overlying the portion of aquifer supplying water to the well within a five-year period. Microbial contamination in the five-year time-of-travel zone is not a major concern, because existing literature suggests that bacteria and viruses cannot survive more than one year in groundwater. However, chemical contamination is a concern and potential sources of chemical contamination should be monitored closely. The primary difference between the five-year time-of-travel zone and the zones closer to the well is that the five-year zone provides an increased response time to mitigate the effects of chemical releases.

### Ten-Year Time-of-Travel Zone

The ten-year time-of-travel zone represents the surface area overlying the portion of aquifer supplying water to the well within a ten-year period. The purpose of the ten-year zone is to control high risk chemical contamination sources, and to encourage long-term planning for contaminant risk reduction. Public education of contamination prevention measures is a key management tool used in protecting this zone.

## **CALCULATED FIXED RADIUS (CFR) MODEL**

In developing a wellhead protection program, a first step is to establish the land areas around each well from which groundwater may flow to the well. These areas are likely to contribute pollutants to the groundwater and are referred to as “zones of contribution”. Zones of contribution require proper land use management to minimize the possibility of contaminants entering the groundwater system. The most commonly accepted tools for delineating wellhead protection zones include the calculated fixed radius (CFR) method, analytical models, and numerical models.

The calculated fixed radius method was used to analyze the wellhead protection area zones of contribution. Based on WAC 246-290-135 and through the use of the DOH susceptibility analysis techniques, wellhead protection areas are estimated for 6-month, 1-year, 5-year, and 10-year periods. The delineations of the City’s zones of contribution are shown on Figure 5-1. The CFR method was utilized to determine the wellhead protection areas with the current pumping rates by using the following equation:

$$r = \sqrt{\frac{Qt}{n\pi H}}$$

A summary of the values used to calculate the CFRs for each source are provided in Table 5-1.



**TABLE 5-1**

**Calculated Fixed Radius Wellhead Protection Areas**

<b>PARAMETER</b>	<b>WHP ZONE</b>	<b>SO2</b>	<b>SO3</b>	<b>SO4</b>	<b>SO5</b>
r = Calculated Radius of Protection Zone (ft)	6 Months	820	940	1,280	850
	1 Year	1,160	1,340	1,810	1,200
	5 Years	2,600	2,990	4,060	2,680
	10 Years	3,680	4,230	5,730	3,790
Q = Pumping Rate of Well (cu-ft/yr)	-	14,053,000	45,671,000	38,645,000	29,862,000
n = Estimated Porosity	-	0.22	0.22	0.22	0.22
H = Open Interval/Length of Well Screen (ft)	-	15	37	17	30

**POTENTIAL CONTAMINANT SOURCES**

Within a wellhead protection zone, there are many diverse activities that may contaminate an aquifer and potentially prevent its use as a viable drinking water source. It is important that these activities are properly inventoried and, if necessary, regulated to prevent degradation of groundwater quality. Relevant activities and sources at a minimum include land use practices, industrial and commercial operations, underground storage tanks, hazardous materials storage and use, septic tanks, and dry wells. These activities are potential sources for groundwater contamination. A discussion of these practices and their potential effects on groundwater, and the regulatory requirements that may apply are included in the sections that follow.

**INVENTORY OF POTENTIAL CONTAMINANT SOURCES**

The purpose of maintaining an inventory of potential contaminant sources is to identify past, present, and proposed activities that may pose a threat to a water supply source. Other purposes include assisting the development of plan management strategies, establishing a mailing list for notifying potential contaminant sources within the wellhead protection areas, and notifying agencies regarding inventory findings. An accurate inventory and description of hazardous material handlers is required in WAC 246-290-135.

Figure 5-1 shows the current potential contaminant sources throughout the City of Okanogan overlaid with the wellhead protection areas for each source.

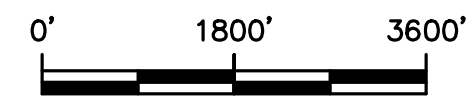
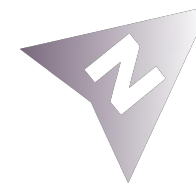

**LEGEND**

- 6 MONTH WELLHEAD PROTECTION AREA —
- 1 YEAR WELLHEAD PROTECTION AREA —
- 5 YEAR WELLHEAD PROTECTION AREA —
- 10 YEAR WELLHEAD PROTECTION AREA —
- CITY LIMITS - - -
- URBAN GROWTH AREA - - -

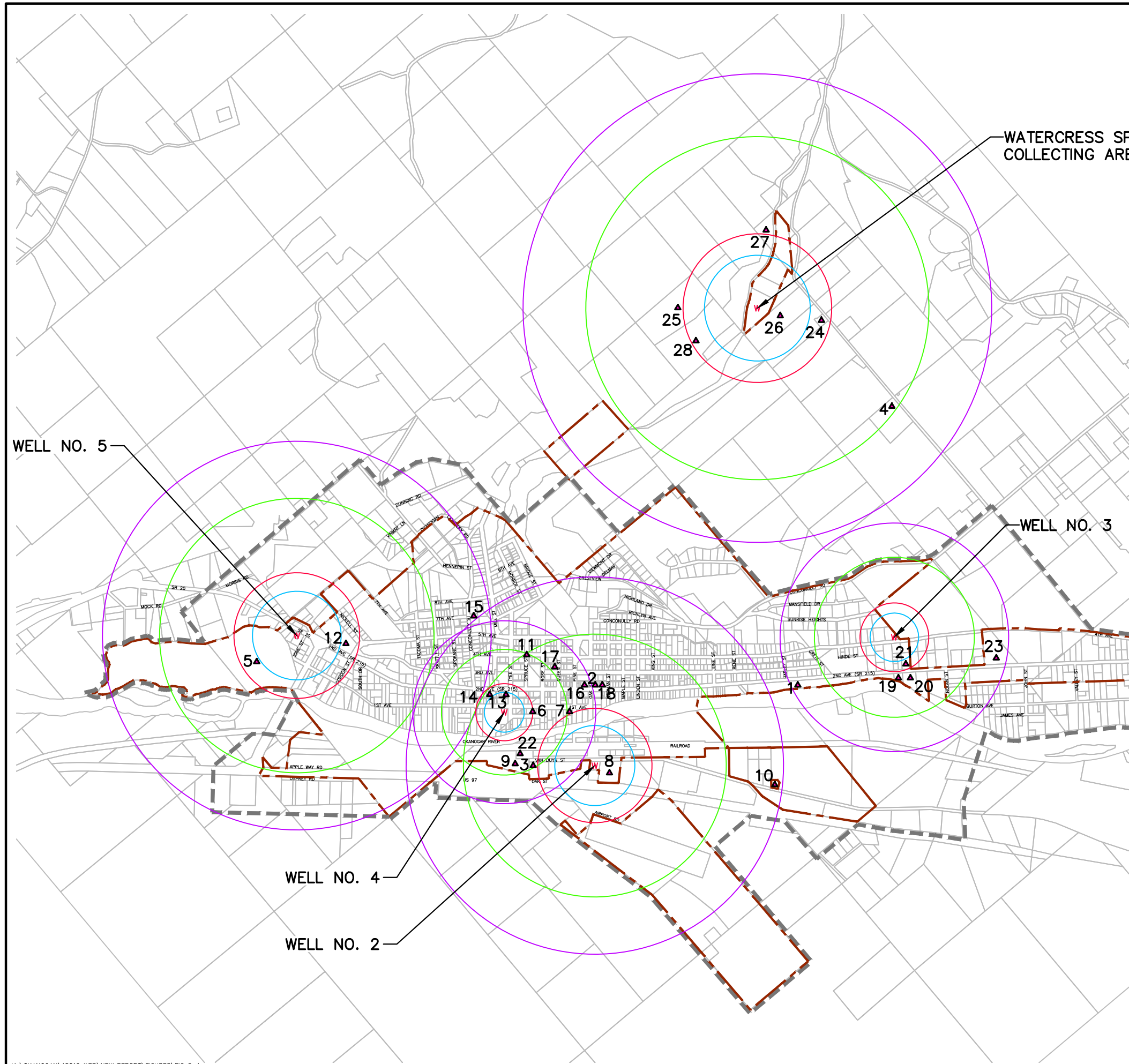

ID #	Source Name	Address
1	Okanogan County PUD	1331 2nd Avenue North, Okanogan, WA 98840
2	Okanogan Mini-Mart	205 2nd Avenue North, Okanogan, WA 98840
3	Mutual Apple Growers, Inc. (MAGI)	244 Van Duyn Street, Okanogan, WA 98840
4	USDA FHA Sid Marquis Farm	115 Glover Lane Road, Okanogan, WA 98840
5	City of Okanogan Wastewater Treatment Plant	1601 Island Ave Southwest, Okanogan, WA 98840
6	Farm Machinery Clinic	321 1st Avenue South, Okanogan, WA 98840
7	Okanogan Dry Cleaners & Laundromat	105 Pine Street, Okanogan, WA 98840
8	Washington Tractor	1 Patrol Street, Okanogan, WA 98840
9	Okanogan Livestock Market	523 Van Duyn Street, Okanogan, WA 98840
10	Okanogan Diesel	81 Rodeo Trail Road, Okanogan, WA 98840
11	North Central Petroleum Inc.	240 Spruce Street, Okanogan, WA 98840
12	Okanogan Public Works Department	1234 2nd Avenue South, Okanogan, WA 98840
13	Pete's Body & Paint Shop	505 2nd Avenue South, Okanogan, WA 98840
14	Ed's Repair Service	670 2nd Avenue South, Okanogan, WA 98840
15	Valley Transmission & Repair	669 7th Avenue South, Okanogan, WA 98840
16	Thrifty Auto & Tire LLC	123 2nd Avenue North, Okanogan, WA 98840
17	Okanogan Truck & Tractor	204 3rd Avenue South, Okanogan, WA 98840
18	Nelson's Flowers & Nursery	235 2nd Avenue North, Okanogan, WA 98840
19	D & D Auto Body	1604 2nd Avenue North, Okanogan, WA 98840
20	OK Tire Factory, Inc.	1622 2nd Avenue North, Okanogan, WA 98840
21	Whitley Fuel	1617 2nd Avenue North, Okanogan, WA 98840
22	Whitley Fuel	325 Van Duyn Street, Okanogan, WA 98840
23	Randy's Auto Parts & Towing	2135 Elm Street, Okanogan, WA 98840
24	Agricultural Producer (Doris Hubbard)	62 Glover Lane Road, Okanogan, WA 98840
25	Agricultural Producer (Daniel Whitley)	139 Wood Hill Road, Okanogan, WA 98840
26	Agricultural Producer (Rachel Steiner)	52 Glover Lane Road, Okanogan, WA 98840
27	Agricultural Producer (Patrick Morrissey)	213 Salmon Creek Road, Okanogan, WA 98840 (Mail to: PO Box 707)
28	Agricultural Producer (Mark Wood)	130 Wood Hill Road, Okanogan, WA 98840
29	Agricultural Producer (Moon Orchards)	170 Conconully Road, Okanogan, WA 98840

**CITY OF OKANOGAN**  
**WATER SYSTEM PLAN**  
 FIGURE 5-1  
**POTENTIAL CONTAMINANT SOURCES**  
**WITHIN TRAVEL ZONES**

**Gray & Osborne, Inc.**  
 CONSULTING ENGINEERS

## **NOTIFICATIONS**

Minimum requirements for notification of wellhead protection areas are issued to owners and operators of potential sources of contamination, to regulatory agencies and local governments, and to local emergency incident responders.

### **Notices to Owners of Potential Sources of Contamination**

A standard letter (included at the end of this chapter) has been sent to all land or business owners identified on the list of potential contaminant sources. The standard letter states that their property is in the wellhead protection area, and states that the activities of their business may be a potential source for ground water contamination. Residents within the WHPAs have been notified through public service messages of their potential impact upon the City's drinking water supply. Landowners with on-site septic systems should be notified that, when operated properly, septic systems would not be a significant threat to the City's wells. However, the dumping of chemicals into septic systems, onto the ground, or into storm drains in the wellhead protection area could contaminate the City's water supply and that enforcement action may be taken.

### **NOTIFICATION TO REGULATORY AGENCIES AND LOCAL GOVERNMENTS**

Under WAC 246-290-135, it is required that notification is provided to regulatory agencies and local government of the WHPAs and an inventory of potential sources of contamination in the area be identified. The regulatory agencies and local government office that must receive the notification are listed as follows:

Washington State Department of Health  
Wellhead Protection Program, Headquarters  
243 Israel Rd. SE  
Tumwater, WA 98501  
P.O. Box 47823  
Olympia, WA 98504-7822  
Phone: (360) 236-3114

U.S. Environmental Protection Agency  
Attn: Ground Water Unit  
1200 Sixth Avenue  
Seattle, WA 98101  
(206) 553-6708

Washington State Department of Ecology  
Central Regional Office  
15 West Yakima Ave, Suite 200  
Yakima, WA 98902-3452  
Phone: (509) 575-2490

Washington State Department of Health  
Division of Drinking Water  
Eastern Regional Office  
Contact: Mike Wilson, P.E.  
Riverview Corporate Center  
16201 East Indiana Avenue, Suite 1500  
Spokane Valley, Washington 99216  
Phone: (509) 329-2116

Okanogan County Public Health  
1234 South 2<sup>nd</sup> Avenue  
P.O. Box 231  
Okanogan, WA 98840  
Business: (509) 422-7140

The City has sent notification to regulatory agencies and local governments of the boundaries of the WHPAs and the finding of the WHPAs inventory.

**NOTIFICATION TO LOCAL EMERGENCY INCIDENT RESPONDERS**

It is required by regulation that documentation of coordination with incident responders be provided. The following incident responders have been contacted and provided with information regarding the City's WHPAs:

Okanogan County Sherriff's Office  
123 5<sup>th</sup> Avenue  
Okanogan, WA 98840  
Emergency: 911  
Business: (509) 422-7200

Fire Protection Bureau  
Washington State Patrol  
PO Box 42600  
Olympia, WA 98504-2600  
Emergency: 911  
Business: (360) 596-3902

Okanogan County Sherriff's Office  
Department of Emergency Management  
123 5<sup>th</sup> Avenue  
Room 200  
Okanogan, WA 98840  
Emergency: 911  
Business: (509) 422-7207

Emergency Response, Washington  
State Department of Transportation  
Doug Pierce  
Transportation Bldg. 47358  
Olympia, WA 98504-7358  
Emergency: 911  
Business: (360) 705-7812

Okanogan County Public Health  
1234 South 2<sup>nd</sup> Avenue  
P.O. Box 231  
Okanogan, WA 98840  
Business: (509) 422-7140

Spill Response Program  
Washington State Department of Ecology  
Will Strand  
Central Regional Office  
15 West Yakima Avenue, Suite 200  
(509) 575-2806

Washington State Department of Health  
Division of Drinking Water  
Eastern Regional Office  
Contact: Mike Wilson, P.E.  
Riverview Corporate Center  
16201 East Indiana Avenue, Suite 1500  
Spokane Valley, Washington 99216  
Phone: (509) 329-2116

Washington State Emergency Management  
Building 20, MS TA-20  
Camp Murray, WA 98430-5112  
(800) 562-6108

## **LONG-TERM CONTINGENCY PLANNING**

Long-term water replacement options differ from emergency and short-term options in two ways. First, the amount of time available to evaluate the various alternatives is longer, permitting more extensive analysis of the considerations of future needs and other factors prior to decision-making. Second, the range of viable alternatives is larger. The following sections provide a discussion of long-term options.

### **DRILL NEW WELLS**

If investigations indicate that there is an untapped supply of groundwater in the form of a separated aquifer or a portion of the contaminated aquifer which is up-gradient and uncontaminated, it may be feasible for the City to drill new wells. This alternative can often be more economical and carry lower risk than treatment. Cost estimates for new well drilling are provided in Appendix L.

### **GROUNDWATER TREATMENT**

The same treatment technologies previously described are available as permanent solutions for contaminant removal. As discussed above, treatment of contaminated water should be viewed as a last resort and should be considered only after the other alternatives have been completely abandoned.

### **INTERCONNECTION**

Interties with other water systems are sometimes a cost effective solution. The nearest town with a reliable water supply is the City of Omak, located just north of Okanogan. The City may explore the possibility of an intertie with the City of Omak should conditions warrant.

### **WATER CONSERVATION**

While it is possible to use conservation strategies to reduce consumption over the long-term, the water savings from conservation are not likely to be large enough to replace the production of a contaminated well.

### **DUAL SYSTEMS**

A portion of the City is served by a separate non-potable irrigation system (Alta Vista), which reduces water demands on the potable water system. This system relies on the Okanogan River for source water. Expansion of this system could further reduce potable demand, and initial capital costs of infrastructure would be high.

## **SURFACE WATER TREATMENT**

As in the short-term surface water treatment discussion, the water quality, water right, and costs associated with surface water treatment make it an unattractive alternative.

## **PROTECTIVE COVENANTS**

The City will investigate current declaration of covenants and restrictive covenants for each of its wells to determine any deficiencies that may exist for corrective action in order to better protect its water sources.

## **OKANOGAN WELLHEAD PROTECTION MANAGEMENT**

Development of management strategies is essential for a successful wellhead protection program. Without proper management, potential contamination sources are likely to become a reality. An informed public that understands the link between potential contamination sources and its drinking water is one of the most effective ways of protecting groundwater supplies. The City will send out information pertaining to wellhead protection on an annual basis with billing to provide continuous education of the public on the merits of wellhead protection. The City has also notified the potential contamination sources shown on Figure 5-1. Finally, WHPP literature will be maintained at City Hall to increase public awareness of the need to protect water supplies.

## Sample of Agency Notification Letter

Date:

[agency/local government]  
P.O. Box 123  
123 Anywhere St  
City, WA 99999

Subject: OKANOGAN WELLHEAD PROTECTION PROGRAM

Dear [agency/local government];

As part of the wellhead protection program for the City of Okanogan, we are hereby informing you of the findings of our wellhead protection area delineation. This is in accordance with State regulations (WAC 246-290-135).

Our City has approximately 981 active services, and serves a population of approximately 2,595 people. Due to the groundwater nature of our water system sources, our drinking water supply is vulnerable to contamination.

The enclosed map shows the 6-month, 1-, 5-, and 10-year time of travel boundaries for our wellhead protection areas. Any ground water contamination that occurs within these wellhead protection areas has a high potential to reach our wells. It is therefore of utmost importance to us that all reasonable steps be taken to ensure that land use activities within this area do not contaminate our customers' drinking water supplies.

Thank you for your support in protecting our drinking water.

Sincerely,

Shawn Davisson  
Public Works Director

## Sample of Contaminant Notification Letter

Date:

Mr/Ms.  
P.O. Box 123---  
123 Anywhere St  
Okanogan, WA 98840

Subject: OKANOGAN WELLHEAD PROTECTION PROGRAM

Dear Owner;

In Okanogan, we rely on ground water as our only source for drinking water. We take a proactive approach to ensure a safe and secure source of quality water for our community. To do so, we have developed a Wellhead Protection Plan in accordance with State guidelines. A copy of this document is located at City Hall.

As part of our Wellhead Protection Plan, we mapped the areas overlying the most sensitive areas around each of our wells, designated as protection zones. These protection zones represent the time it can take for water to travel from the edge of the zone to the well. Following the mapping of the wellhead protection zones, an inventory of potential sources of groundwater contamination was conducted. Your business, residence or property was found to lay within one of the wellhead protection zones. As such, it has been identified to be a potential contamination source for our wellhead protection plan following a review of such source in the DOE database. The presence of your business, residence or property within the City's wellhead protection zone means that activities in these areas can have the potential to affect the City's drinking water supplies.

We have notified the State of the existence of your business, residence or property within the City's wellhead protection zone. The State can assist you with technical information to help you manage activities within the wellhead protection zone in a way that will best prevent groundwater contamination. Additionally, we will include guidelines in our water statements on how to protect our water supply.

We realize you are already careful to protect the environment in and around your property. Our hope is that informing you that your business, residence or property is within our wellhead protection zone will reinforce the need to be ever diligent in day to day activities to help ensure we keep a safe and secure source of quality water for our community.

Sincerely,

Shawn Davisson  
Public Works Director



## CHAPTER 6

### OPERATION AND MAINTENANCE

The Washington State Department of Health considers several elements to be important in a properly managed operation and maintenance (O&M) program. A list of these elements and where they are discussed or presented in this plan is provided in Table 6-1.

**TABLE 6-1**

#### Operation & Maintenance Program Elements

Operation and Maintenance Component	Location in Plan
Water System Management and Personnel	Chapter 1, p. 1-1 & Table 6-2
Operator Certification	Chapter 1, p. 1-1 & Table 6-2
Routine Operating Procedures	Chapter 6
Water Quality Sampling Procedures	Appendix B
Coliform Monitoring Plan	Appendix B
Emergency Response Plan	Appendix G
Safety Procedures	Appendix G
Cross-Connection Control	Appendix F
Customer Complaint Response Program	Appendix G
Record Keeping and Reporting	Appendix G
Operation and Maintenance Analysis	Chapter 3, Table 3-13

### SYSTEM PERSONNEL

The City's water system personnel are listed below. The City's Public Works Director's daytime phone number is (509) 322-0121. A more extensive list of emergency phone numbers is provided in Appendix G.

**TABLE 6-2**

#### Water System Personnel

Name	Title	Certification <sup>(1)</sup>	Emergency Phone
Jon Culp	Mayor	N/A	(509) 422-6120 (Home)
Shawn Davisson	Public Works Director	N/A	(509) 322-0121 (Cell)
Loren Howell	Water System Manager and Assistant PWS	WDM 2, CCS, WDS, BAT	(509) 322-0150 (Cell) (509) 422-0717 (Office)
Barry Featherly	Assistant Water System Manager	WDM2, CCS	
Craig Attwood	City Clerk	N/A	(509) 486-3600 (Cell)
Gray & Osborne, Inc.	City Engineer	N/A	(509) 453-4833 (Office)

(1) WDM 2 = Water Distribution Manager Level 2; WDS = Water Distribution Specialist; CCS = Cross Connection Control Specialist; BAT = Backflow Assembly Tester.

## OPERATION AND MAINTENANCE PROGRAM

Tables 6-3 through 6-6 provide general information on the City’s operation and maintenance program. Table 6-3 summarizes the City’s principal operating and preventive maintenance activities and their frequency. Photos of the City’s wells, reservoirs and booster stations are provided at the end of this appendix.

**TABLE 6-3**

### Operation and Maintenance Practices

<b>Operation and Maintenance Activities</b>	<b>Frequency</b>
<b>Wells</b>	
Visual and aural inspection of building exterior, interior and equipment	Daily
Record flow data	Daily
Measure static and dynamic water levels	Every September & February
Well pump maintenance	Per manufacturer recommendation
<b>Storage</b>	
Exterior and interior inspection	Every 10 years
Inspect vents and screens	Annually
Source meters	Checked annually for accuracy
<b>Booster Pump Stations</b>	
Visual and aural inspection of building exterior, interior, and equipment	Daily
Record flow data	Recorded daily
<b>Distribution System</b>	
Exercise valves	Annually
Exercise hydrants	Annually
Perform preventative maintenance on control valves	Annually
Control valve inspection and testing	Weekly
Small service meter tests/replacements	As needed (10-15 yrs as necessary)
Read service meters	Monthly for six months each year
Collect water samples for coliform testing	Monthly
Leak detection survey	Every three years

Table 6-4 summarizes the normal settings, positions and readings used for the City’s water system equipment. Lead-lag sequencing, pump hand-off-auto, and reservoir set points are set at the master telemetry control station computer located at the public works /wastewater treatment facility office.

**TABLE 6-4**  
**Normal Equipment Settings**

	<b>Control Tank</b>	<b>Start Level (ft)</b>	<b>Stop Level (ft)</b>
<b>Source Wells</b>			
Well No. 1	Source not in use		
Well No. 2	North Reservoir	16.5	19.8
Well No. 3	North Reservoir	16.5	19.8
Well No. 4	North Reservoir	16.5	19.8
Well No. 5	North Reservoir	16.5	19.8
Watercress Springs	Source not in use		
<b>Booster Pump Stations</b>		<b>(ft)</b>	<b>(ft)</b>
Sunrise Drive	Highland	17.0	19.8
Murray Street	N/A	N/A	N/A
<b>Reservoirs</b>	<b>High Alarm (ft)</b>	<b>Low Alarm (ft)</b>	
North Reservoir	20.0	16.0	
West Reservoir No. 1	20.0	16.0	
West Reservoir No. 2	20.0	16.0	
Highlands Reservoir	20.0	16.0	
East Reservoir	20.0	16.0	
<b>Automatic Control Valves</b>	<b>Size and Type</b>	<b>Setting</b>	
Highland Drive & 6 <sup>th</sup> Avenue	4” PRV	20 psi	

Table 6-5 provides a list of the typical water system supplies used by the City, and their current supplier for these materials.

**TABLE 6-5**  
**Supplies and Suppliers**

<b>Supply</b>	<b>Supplier</b>	<b>Phone</b>
Gate Valves	Consolidated Supply Co., Wenatchee, WA	(509) 662-7128
Fire Hydrants		
Meter Boxes		
PVC Pipe		
Service Meters & Setters	HD Fowler Company, East Wenatchee, WA	(509) 886-8804
Repair Bands		
Dresser Couplings		
Miscellaneous Pipe Fittings		

## RECORD KEEPING

The City keeps the following water system records and data shown in Table 6-6.

**TABLE 6-6**

### Record Keeping Practices

Record Type	Comment
Source meter readings	Daily readings kept for 10+ years
Service meter readings	Monthly for six months of the year, readings kept for five years
Non-revenue water	Annually calculated from meter data
Bacteriological test results	Monthly results kept for five years
Static and dynamic water level in wells	Every September and February, kept for ten years
Sanitary surveys	Kept for ten years
Chemical Analysis	Keep these records for as long as the source is in service
Other Department of Health correspondence	Kept for five years
Legal documents (water rights, easements, etc.)	Indefinitely

The City's water system mapping, including the location of pipelines and valve locations have not been kept up to date with modifications in the City, but the City does keep a record of most recent development within the City limits.

## COMPLAINT RESPONSE

The City maintains customer complaint records to verify trends that may assist the City improve service to its customers. Response to questions and complaints is typically verbal, either through a field visit or a telephone call. However, depending on the nature of the question or complaint, written response can also be given. Bi-monthly City Council meetings are the main venue for public involvement in the water system.

## SAFETY PROCEDURES

The City practices a safety program to ensure the health and welfare of water system operators. All appropriate Occupational Safety and Health Administration (OSHA) and Washington Industrial Safety and Health Administration (WISHA) regulations are routinely followed during operation of the system. Operation and maintenance staff are trained in safety practices including confined space, first-aid, fall restraint, and chlorine safety. The City maintains fall equipment for inspecting reservoir hatches and screens, and confined space equipment for underground vaults. The City has some old asbestos-cement water pipe, which means that training water system personnel for asbestos handling has been necessary. The City uses liquid sodium hypochlorite (bleach) for water system disinfection when deemed necessary.

## DEFICIENCIES

The City has identified O&M deficiencies on which to take corrective action. These deficiencies and corrective actions are listed in Table 6-7.

**TABLE 6-7**

### **Operation and Maintenance Improvements**

<b>Deficiency</b>	<b>Action</b>
The City does not have a formal valve exercising or pipe flushing program.	The City will begin locating and exercising valves and flushing pipes.



MASTER TELEMTRY PANEL

CITY OF OKANOGAN  
WATER SYSTEM FACILITIES  
MASTER TELEMTRY PANEL

  
**Gray & Osborne, Inc.**  
CONSULTING ENGINEERS





WELL HOUSE NO 2

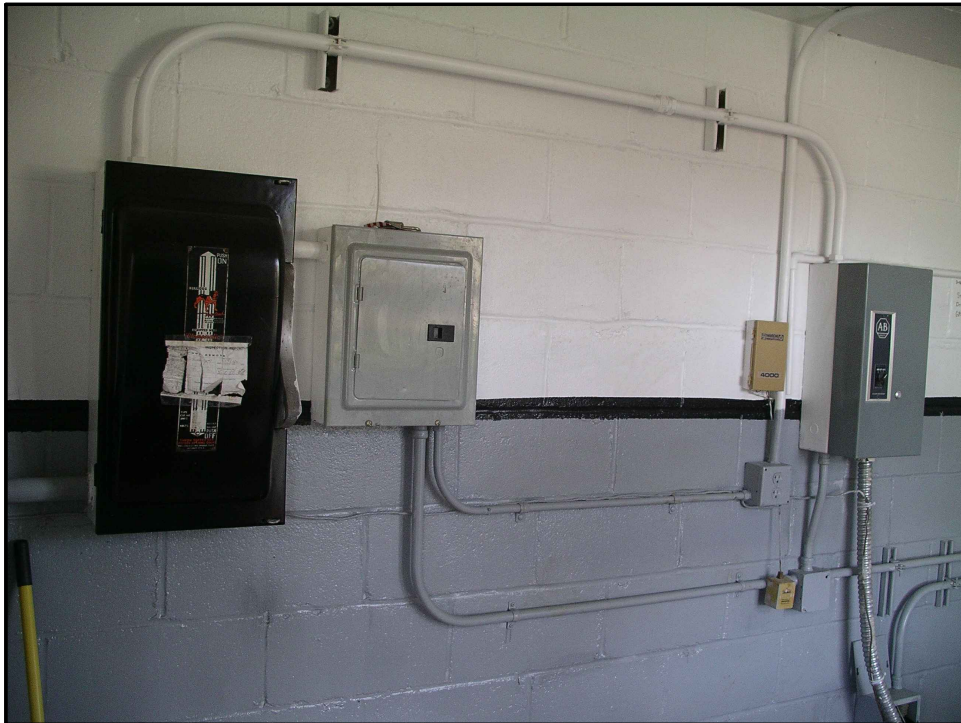

WELL HOUSE NO 2  
ELECTRICAL PANELS

CITY OF OKANOGAN  
WATER SYSTEM FACILITIES  
WELL HOUSE NO 2





WELL HOUSE NO 2  
VALVES & METERS



WELL HOUSE NO 2  
TELEMETRY PANEL

CITY OF OKANOGAN  
WATER SYSTEM FACILITIES  
WELL HOUSE NO 2



**Gray & Osborne, Inc.**  
CONSULTING ENGINEERS





WELL HOUSE NO 3



WELL HOUSE NO 3  
ELECTRICAL PANEL

**CITY OF OKANOGAN**  
WATER SYSTEM FACILITIES  
WELL HOUSE NO 3

  
**Gray & Osborne, Inc.**  
CONSULTING ENGINEERS



WELL HOUSE NO 3

**CITY OF OKANOGAN**  
WATER SYSTEM FACILITIES  
WELL HOUSE NO 3

  
**Gray & Osborne, Inc.**  
CONSULTING ENGINEERS





WELL HOUSE NO 3  
TELEMETRY PANEL

CITY OF OKANOGAN  
WATER SYSTEM FACILITIES  
WELL HOUSE NO 3

  
**Gray & Osborne, Inc.**  
CONSULTING ENGINEERS





WELL NO 4 & TELEMTRY

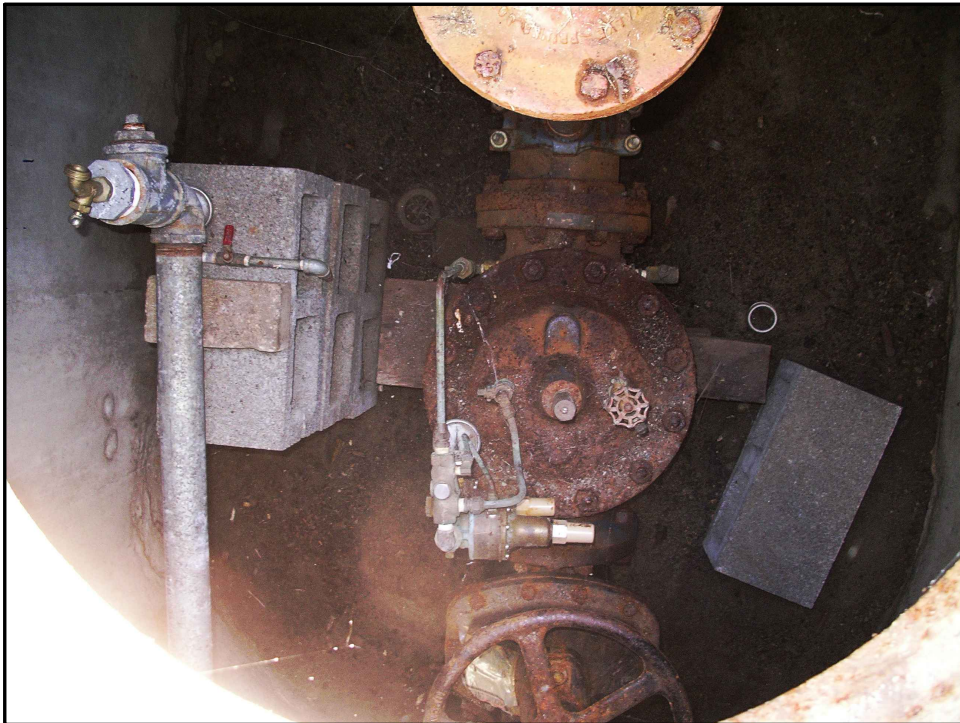

WELL NO 4 VALVES (IN VAULT)

**CITY OF OKANOGAN**  
WATER SYSTEM FACILITIES  
WELL NO 4

  
**Gray & Osborne, Inc.**  
CONSULTING ENGINEERS



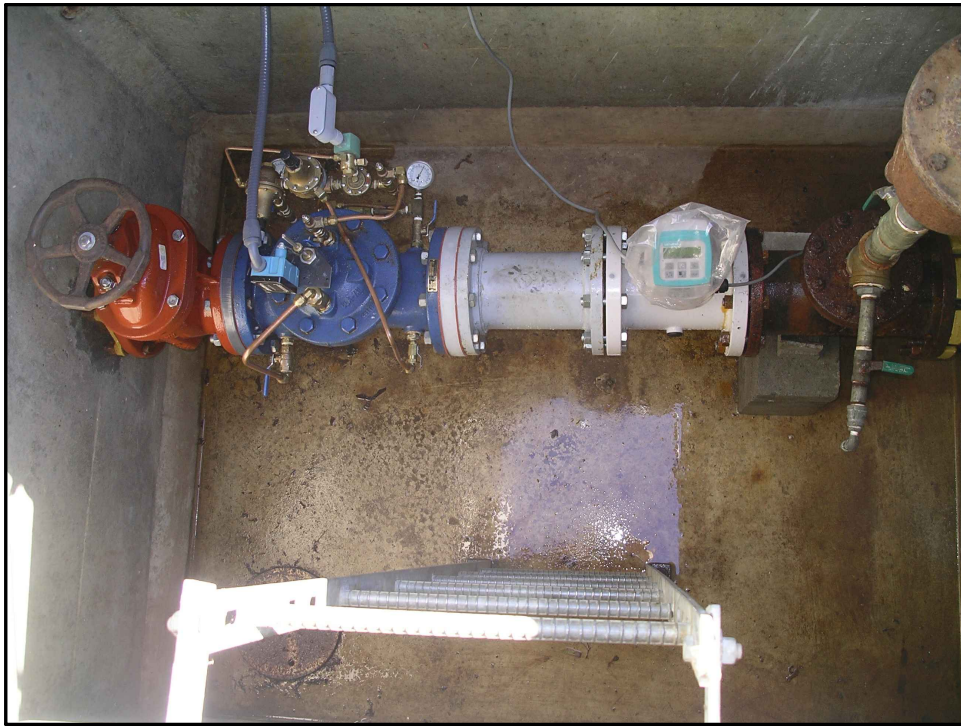

WELL NO 5  
VALVES & METER (IN VAULT)



WELL NO 5  
TELEMETRY PANEL

CITY OF OKANOGAN  
WATER SYSTEM FACILITIES  
WELL NO 5

  
**Gray & Osborne, Inc.**  
CONSULTING ENGINEERS





WELL NO 5

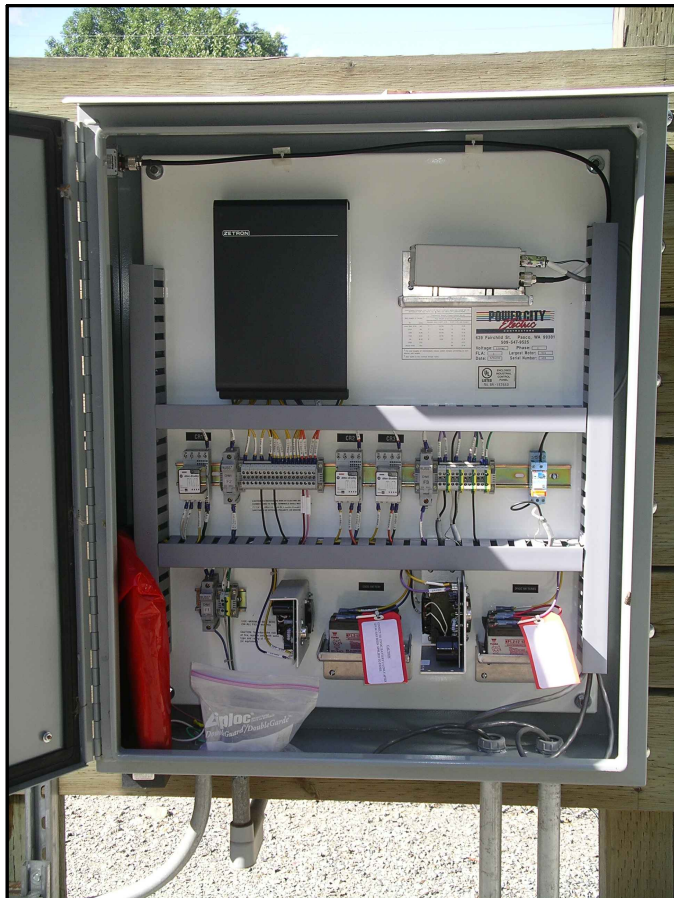

WELL NO 5  
TELEMETRY PANEL

CITY OF OKANOGAN  
WATER SYSTEM FACILITIES  
WELL NO 5



**Gray & Osborne, Inc.**  
CONSULTING ENGINEERS





EAST RESERVOIR



EAST RESERVOIR  
ELECTRICAL, TELEMETRY PANELS  
AND WATER LEVEL INDICATOR

**CITY OF OKANOGAN**  
WATER SYSTEM FACILITIES  
EAST RESERVOIR



**Gray & Osborne, Inc.**  
CONSULTING ENGINEERS



NORTH RESERVOIR



NORTH RESERVOIR  
BOOSTER PUMP NO 1 & NO 2 PANEL

**CITY OF OKANOGAN**  
WATER SYSTEM FACILITIES  
NORTH RESERVOIR







NORTH RESERVOIR  
BPS FLOW METER (IN VAULT)



NORTH RESERVOIR  
BPS VALVE (IN VAULT)

CITY OF OKANOGAN  
WATER SYSTEM FACILITIES  
NORTH RESERVOIR

  
**Gray & Osborne, Inc.**  
CONSULTING ENGINEERS





NORTH RESERVOIR  
BPS

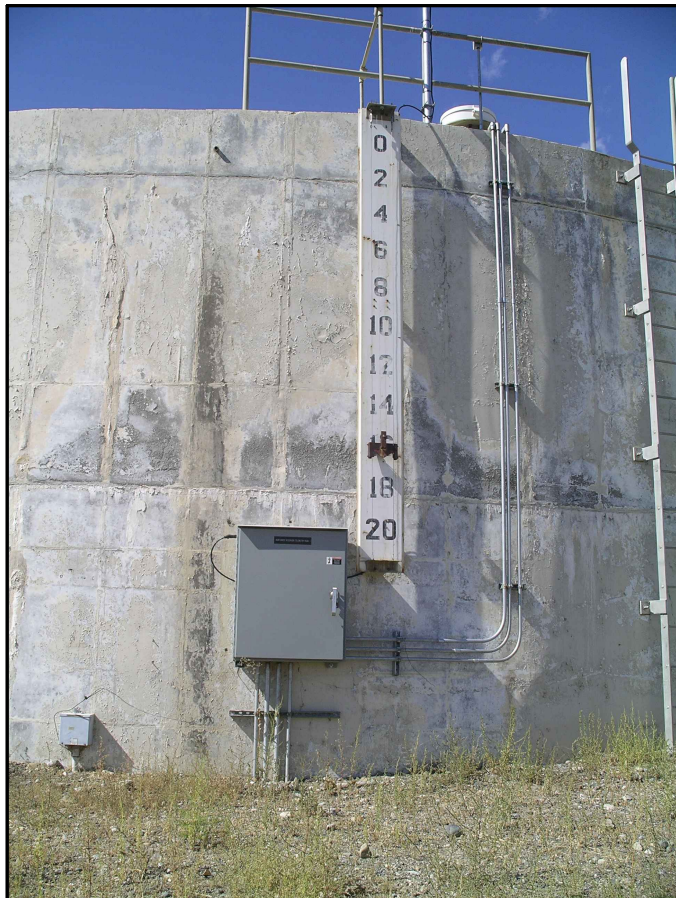

NORTH RESERVOIR  
WATER LEVEL INDICATOR AND  
TELEMETRY PANEL

CITY OF OKANOGAN  
WATER SYSTEM FACILITIES  
NORTH RESERVOIR



**Gray & Osborne, Inc.**  
CONSULTING ENGINEERS





WEST RESERVOIR NO. 1



WEST RESERVOIR NO. 1  
TELEMETRY PANEL

**CITY OF OKANOGAN**  
WATER SYSTEM FACILITIES  
WEST RESERVOIR NO. 1

  
**Gray & Osborne, Inc.**  
CONSULTING ENGINEERS





WEST RESERVOIR NO. 2  
VALVE VAULT



WEST RESERVOIR NO. 2  
VALVES (IN VAULT)

CITY OF OKANOGAN  
WATER SYSTEM FACILITIES  
WEST RESERVOIR NO. 2







WEST RESERVOIR NO. 2

**CITY OF OKANOGAN**  
WATER SYSTEM FACILITIES  
WEST RESERVOIR NO. 2





HIGHLANDS RESERVOIR



HIGHLANDS RESERVOIR  
TELEMETRY PANEL & LADDER ACCESS

**CITY OF OKANOGAN**  
WATER SYSTEM FACILITIES  
HIGHLANDS RESERVOIR



**Gray & Osborne, Inc.**  
CONSULTING ENGINEERS



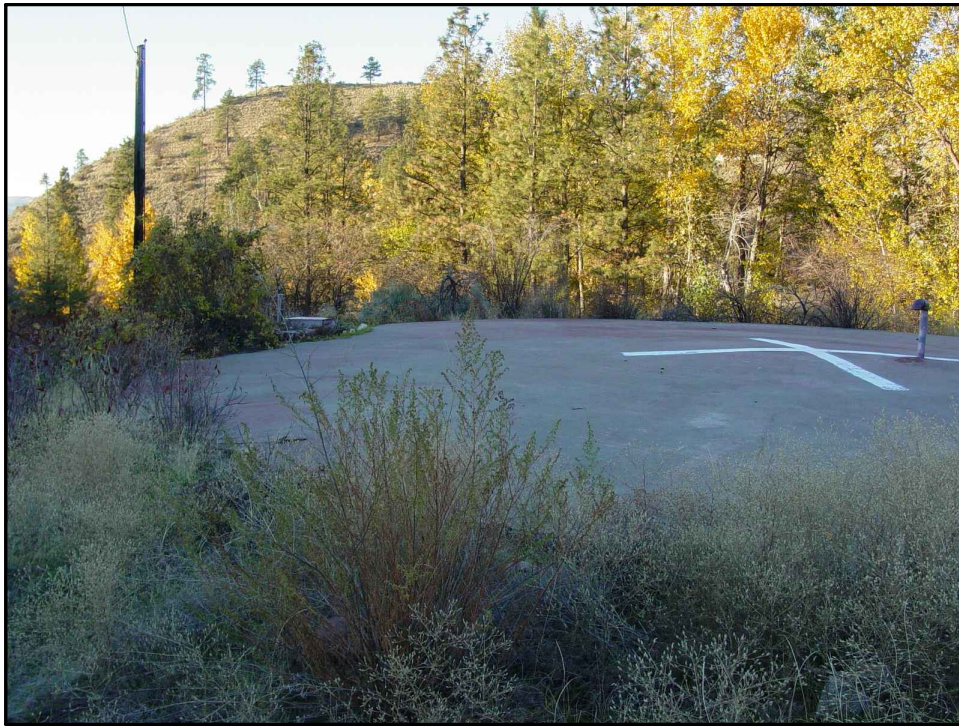

WATERCRESS SPRINGS RESERVOIR



WATERCRESS SPRINGS RESERVOIR  
INLET PIPE

**CITY OF OKANOGAN**  
WATER SYSTEM FACILITIES  
WATERCRESS SPRINGS RESERVOIR

  
**Gray & Osborne, Inc.**  
CONSULTING ENGINEERS





WATERCRESS SPRINGS RESERVOIR  
OUTLET



WATERCRESS SPRINGS  
CHLORINATION  
BUILDING

CITY OF OKANOGAN  
WATER SYSTEM FACILITIES  
WATERCRESS SPRINGS RESERVOIR

  
**Gray & Osborne, Inc.**  
CONSULTING ENGINEERS





MURRAY STREET BPS  
(ELECTRICAL PANEL OPEN)



MURRAY STREET BPS  
ELECTRICAL PANEL

CITY OF OKANOGAN  
WATER SYSTEM FACILITIES  
MURRAY STREET BOOSTER PUMP STATION

  
**Gray & Osborne, Inc.**  
CONSULTING ENGINEERS





TRANSFER STATION  
VALVE & METERS (IN VAULT)



TRANSFER STATION

CITY OF OKANOGAN  
WATER SYSTEM FACILITIES  
TRANSFER STATION





TRANSFER STATION  
TELEMETRY PANEL

CITY OF OKANOGAN  
WATER SYSTEM FACILITIES  
TRANSFER STATION

  
**Gray & Osborne, Inc.**  
CONSULTING ENGINEERS



## CHAPTER 7

### CONSTRUCTION STANDARDS

#### REQUIREMENTS FOR DEVELOPER-CONSTRUCTED IMPROVEMENTS

Developer shall retain the services of an engineer registered in the State of Washington.

The engineer shall provide necessary design services, as well as construction services.

Complete plans and specifications of the proposed improvements shall be submitted to the City for review and approval.

Plan and profile design drawings shall be drawn at a minimum scale of 1 inch = 50 feet or 1 inch = 40 feet if water, sewer and street improvements are drawn on the same sheets.

The Developer's Engineer shall be required to certify that all improvements have been constructed in accordance with the approved plans and specifications.

Water and sewer certification shall be on standard State forms. Copies of testing data shall also be provided to the City including compaction testing, pressure testing, etc. street certification shall consist of a letter, together with test data, weigh tickets, etc.

The Developer shall be required to provide proof that there is a performance bond that covers defective or faulty workmanship and materials. The bond must cover a period of two years from the date of acceptance by the City.

The Developer shall require the Contractor to provide insurance which indemnifies and holds harmless the City and its agents and employees from and against all claims, damages, losses, and expenses, including attorney's fees arising out of or resulting from the performance of the work, and shall, after reasonable notice, defend and pay the expense of defending any suit and will pay any judgment provided that any such claim, damage, loss, or expense (1) is attributable to bodily injury, sickness, disease, or death, or to injury to or destruction of tangible property (other than the work itself) including the loss of use resulting therefrom, and (2) is caused in whole or in part by any negligent act or omission of the Contractor, any Sub-Contractor, anyone directly or indirectly employed by any of them or anyone for whose acts any of them may be liable regardless of whether or not it is caused in part by a party indemnified hereunder.

In any and all claims against the City or any of their agents or employees by any employee of the Contractor, any Sub-Contractor, anyone directly or indirectly employed by any of them or anyone whose acts cause them to may be liable, the indemnification obligation under this article shall not be limited in any way by any limitation on the amount or type of damages, compensation, or benefits payable by or for the Contractor or

any Sub-Contractor under Workmen's Compensation Acts, disability benefits acts, or other employees benefit acts.

The obligations of the Contractor under this article shall not include the sole negligence of the City or its agents.

The Contractor shall provide the City proof of insurance in approved amounts and form before commencing work.

The Developer shall provide the City with a mylar copy of the construction drawings showing all revisions made during construction. The drawings, "Record Drawings," shall show as a minimum the following:

- The existence of all underground utilities encountered (station and depth)
- Precise distance to fittings, valves, services, etc. including the length of all spools, etc.
- Type of all fitting ends (MJ, FL, etc.)
- Type of restraints used
- Location of sewer wyes
- Elevation of each manhole, pipe invert (in and out) and sewer slope

The Developer shall comply with all relevant City ordinances and all subsequent amendments thereto.

The Developer shall also comply with all provisions of the City's municipal codes governing platting, construction, zoning, and subdivision.

## **WATER**

All extensions to the water system must conform to the design standards of the City. The Developer's water system must provide adequate domestic supply and fire flow as required by the Washington State Department of Health (DOH). The system must also be capable of future expansion and be constructed of permanent materials. The following items are necessary to meet these conditions:

- (a) Pipe shall be: Ductile Iron – Class 50 or higher or pressure class pipe, or PVC C-900, Class 150 C.I.O.D.
- (b) All fittings must be cast iron or ductile iron, MJ or FL ends.



- (c) Standard 5¼-inch MVO hydrants are required. Hydrants shall be Mueller center stem with one 4-inch diameter port with Stortz 5-inch coupling with cap, and two 2½-inch diameter ports. All hydrant leads shall be valved on the main.
- (d) All water mains feeding fire hydrants must be at least 8-inch pipe. Hydrant leads 50 feet or less may be 6-inch.
- (e) All new services shall be polyethylene and constructed such that there is a goose neck at the corp. the tap at the main shall be 45° from horizontal. Only one meter shall be served from each main tap.
- (f) All meters will be furnished by the City at cost to the Developer. Meters larger than 2-inch will be either turbine type or compound type as will be decided by the City upon review of projected consumption rates.
- (g) 2-inch air and vacuum release valve installations shall be installed at principal high points in the system.
- (h) Dead-end lines are to be avoided where possible. Approval of dead-end lines of any size shall be at the discretion of the Public Works Director.
- (i) Hydrants shall be spaced based on the requirements of the local fire authority and the Uniform Fire Code. The size of mains will also be determined by required fire flow. Hydrants will generally be located at street intersections.
- (j) Minimum valve spacing in water mains shall be 1,000 feet. Intersection valves shall be as directed by the Public Works Director.
- (k) Dead-end mains over 300 feet in length will only be allowed where future looping via public right-of-way can be assured and at the discretion of the Public Works Superintendent. All water lines which dead-end in public or private right-of-way and which will be extended in the future will have a valve installed and will be restrained with a mechanical joint plug inserted into the end of the valve not connected to the pipeline. If a blow-off is required, a tapped plug may be used.
- (l) Valves 8-inches in diameter and smaller shall be of the gate type, epoxy coated and resilient seat, AWWA. Valves 16-inches in diameter and larger shall be butterfly type valves, AWWA.
- (m) All construction including items such as trench excavation and backfill, pipe bedding, pipe installations, testing, disinfection, roadway repair, etc. shall conform to the requirements of the current edition of the *Standard Specifications for Road, Bridge, and Municipal Construction* published

jointly by the Washington State Department of Transportation (DOT) and the American Public Works Association, or as directed by the City of Okanogan.

- (n) All water pipe shall be bedded with pea gravel or other approved materials and compacted in accordance with the *Standard Specifications for Road, Bridge, and Municipal Construction*.
- (o) Pipe bury shall be 54-inch design with a minimum cover permitted of 48-inches (see Standard Plan No. 1 – Typical Water Main Trench Detail).
- (p) Valves and valve boxes shall be installed in accordance with Standard Plan No. 2 – Typical Gate Valve.
- (q) Fire hydrants shall be installed in accordance with Standard Plan No. 4 – Fire Hydrant Detail.
- (r) 5/8 x 3/4-, 1-, and 2-inch meter installations shall be installed in accordance with Standard Plan No. 8 for non-traffic rated installations, and Standard Plan No. 9 for traffic rated installations.
- (s) 3-inch and larger meter installations shall be installed in accordance with Standard Plan No. 17.
- (t) All irrigation services shall be protected with a double check valve. Double check valves shall be installed in accordance with Standard Plan No. 10 for 1-inch services. Large double check valve installations shall be in accordance with the standard requirements of DOH and the Public Works Superintendent.
- (u) Compaction of backfill above the pipe zone in streets, shoulders, driveways, or as directed by the Engineer shall be performed using mechanical compaction equipment and shall be compacted to at least 95 percent of its modified Proctor maximum dry density as measured by ASTM 1557-70, Method C or D.
- (v) Pavement repair shall be in accordance with Standard Plan No. 14.

**WATER SERVICE MATERIALS**

Corporation Stop	Mueller B-25028N or equivalent as approved by the Public Works Director.
Meter	Neptune (gallons); no substitutes.
Service Saddle	Romac saddle single strap for pipe diameters less than 10-inch and double strap for pipe diameters 12-inch or greater, or equivalent as approved by the Public Works Director.
Meter Box:	
Type 1 – Non-Traffic	Mueller Thermal-Coil Meter Box, 15-inch diameter, 48-inch depth with Mueller Meter Box Lid 790007, or equivalent as approved by the Public Works Director.
Type 2 - Traffic	H2 Precast Water Meter Chamber (WCB, WCT) with cast iron meter lid (2019), or equivalent as approved by the Public Works Director.

## **WATER MAIN STANDARD PLANS INDEX**

- 1. WATER MAIN TRENCH SECTION**
- 2. TYPICAL IN-LINE GATE VALVE**
- 3. AIR AND VACUUM RELEASE ASSEMBLY**
- 4. FIRE HYDRANT DETAIL**
- 5. TYPE 1 BLOW-OFF ASSEMBLY**
- 6. TYPE 2 BLOW-OFF ASSEMBLY**
- 7. TYPE 3 BLOW-OFF ASSEMBLY**
- 8. TYPE 1 WATER SERVICE CONNECTION DETAIL**
- 9. TYPE 2 WATER SERVICE CONNECTION DETAIL**
- 10. 1-INCH DOUBLE CHECK VALVE DETAIL**
- 11. VALVE STEM EXTENSION DETAIL**
- 12. CEMENT CONCRETE PAVEMENT REPAIR**
- 13. ASPHALT PAVEMENT REPAIR WITHOUT OVERLAY**
- 14. GRAVEL REPAIR DETAIL**
- 15. SLOPE PROTECTION DETAIL**
- 16. CONCRETE THRUST BLOCK DETAIL**
- 17. 3-INCH AND LARGER WATER SERVICE CONNECTION DETAIL**

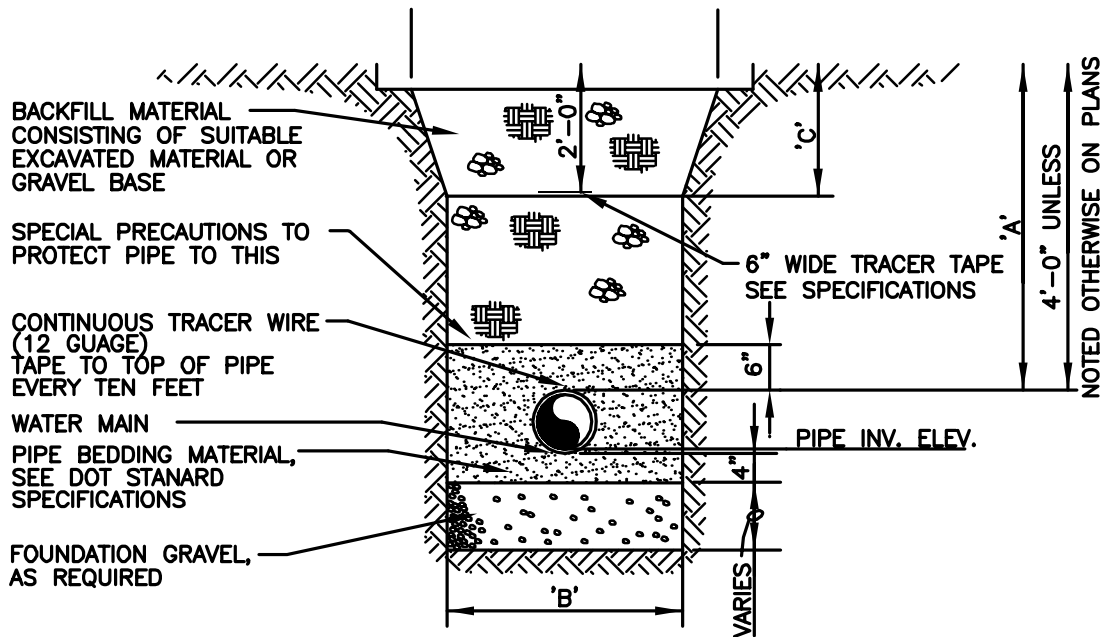

**12" / 8" DIAMETER PIPE**

A	< 8'	8'	10'
B	3'-0" MAX		
C	1.5'	1.5'	1.75'
D	4.5'	5.5'	6.5'
E	5.5'	6.5'	7.5'

**MAXIMUM PAYMENT LIMIT SCHEDULE-  
TRENCH SECTION & SURFACE RESTORATION**

1. PAYMENT FOR FOUNDATION GRAVEL AND GRAVEL BASE (IF ANY) SHALL BE COMPUTED FROM THE MEASUREMENT OF THE CONSTRUCTED TRENCH SECTION TO THE MAXIMUM LIMITS AS INDICATED IN THE MAXIMUM PAYMENT LIMIT SCHEDULE.
2. IN THE EVENT THAT A PORTION OF THIS PAYMENT WIDTH FALLS OUTSIDE THE EXISTING PAVEMENT, THEN ONLY THAT WIDTH COVERED BY THE EXISTING PAVEMENT SHALL BE PAID.
3. IN THE EVENT THAT A PORTION OF THE PAYMENT WIDTH IS IN A GRAVEL SHOULDER, THEN THAT PORTION SHALL BE PAID AS CRUSHED SURFACING TOP COURSE.

**TYPICAL WATER MAIN TRENCH DETAIL**

NTS



**CITY OF OKANOGAN**  
Water Main Trench  
Section

REVISION DATE:  
3/30/07

SCALE:  
NONE

DWG. NO.  
WT-1

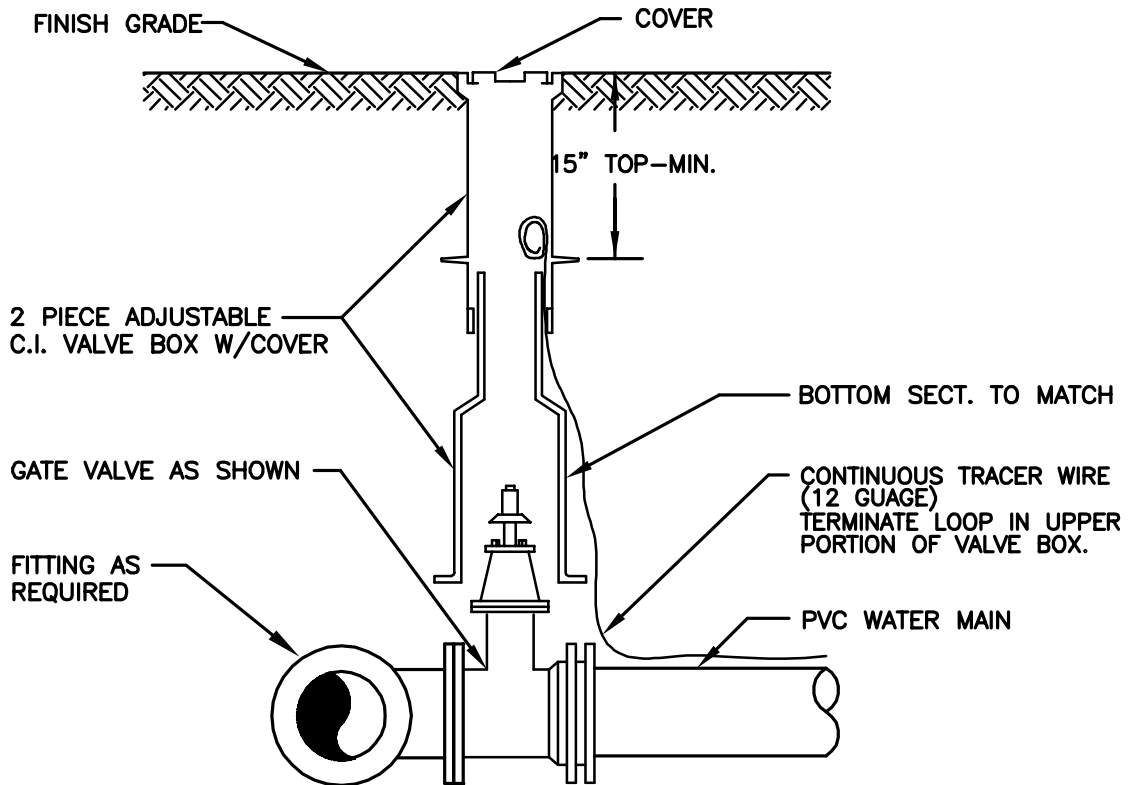

**NOTES:** 1. THE CONTRACTOR SHALL FURNISH AND INSTALL A 2'x2'x4" THICK CEMENT CONCRETE PAD AROUND EACH VALVE BOX NOT ALREADY SITUATED WITHIN PAVED ROADWAY

**TYPICAL GATE VALVE**

NTS



**CITY OF OKANOGAN**  
 Typical In-Line Gate Valve

REVISION DATE:  
 3/30/07

SCALE:  
 NONE

DWG. NO.  
 WT-2



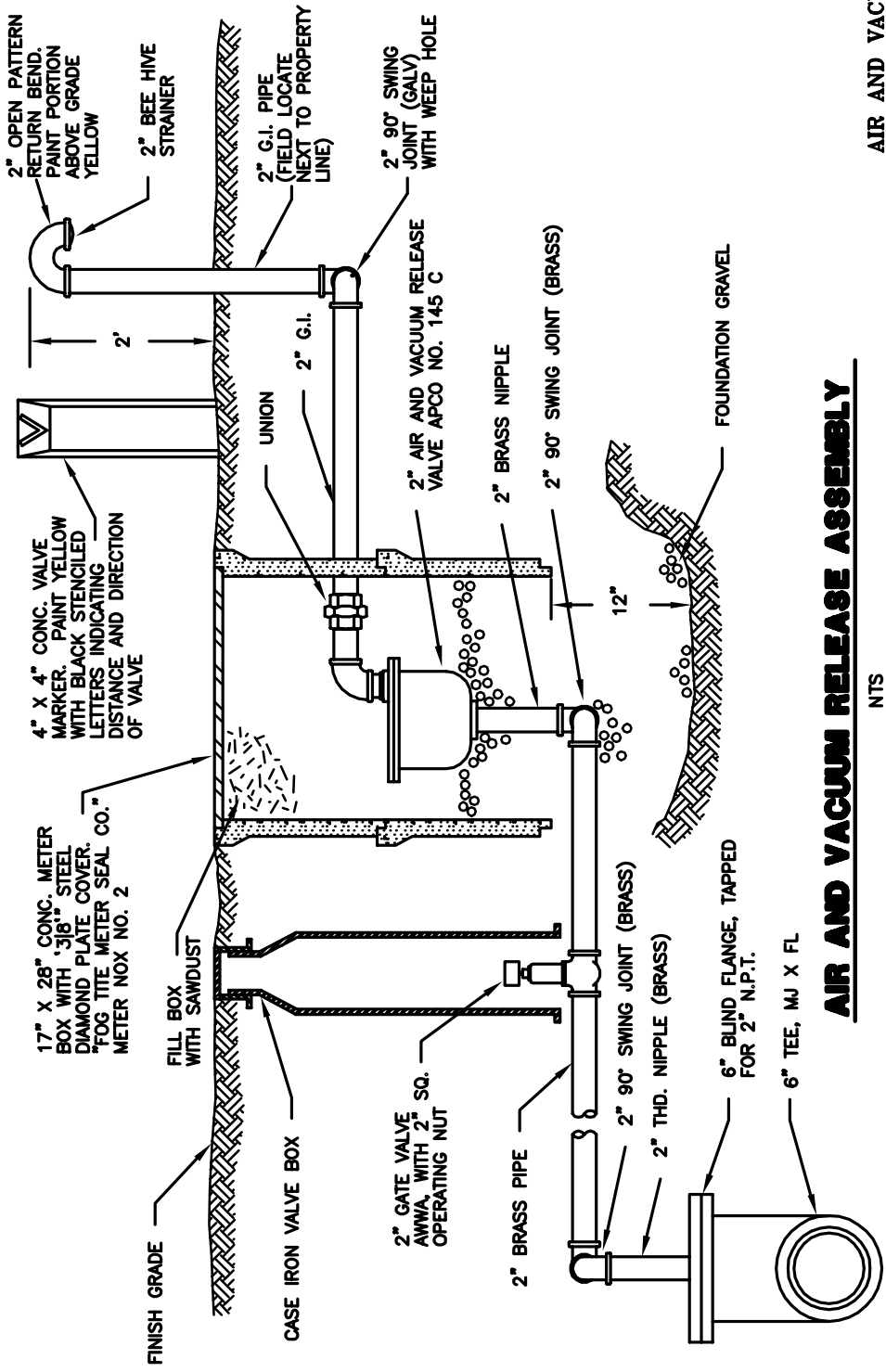

**AIR AND VACUUM RELEASE ASSEMBLY**

AIR AND VACUUM  
RELEASE ASSEMBLY

NTS

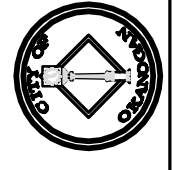

CITY OF OKANOGAN  
Air & Vacuum  
Release Assembly

REVISION DATE:	SCALE:	DWG. NO.
3/30/07	NONE	WT-3

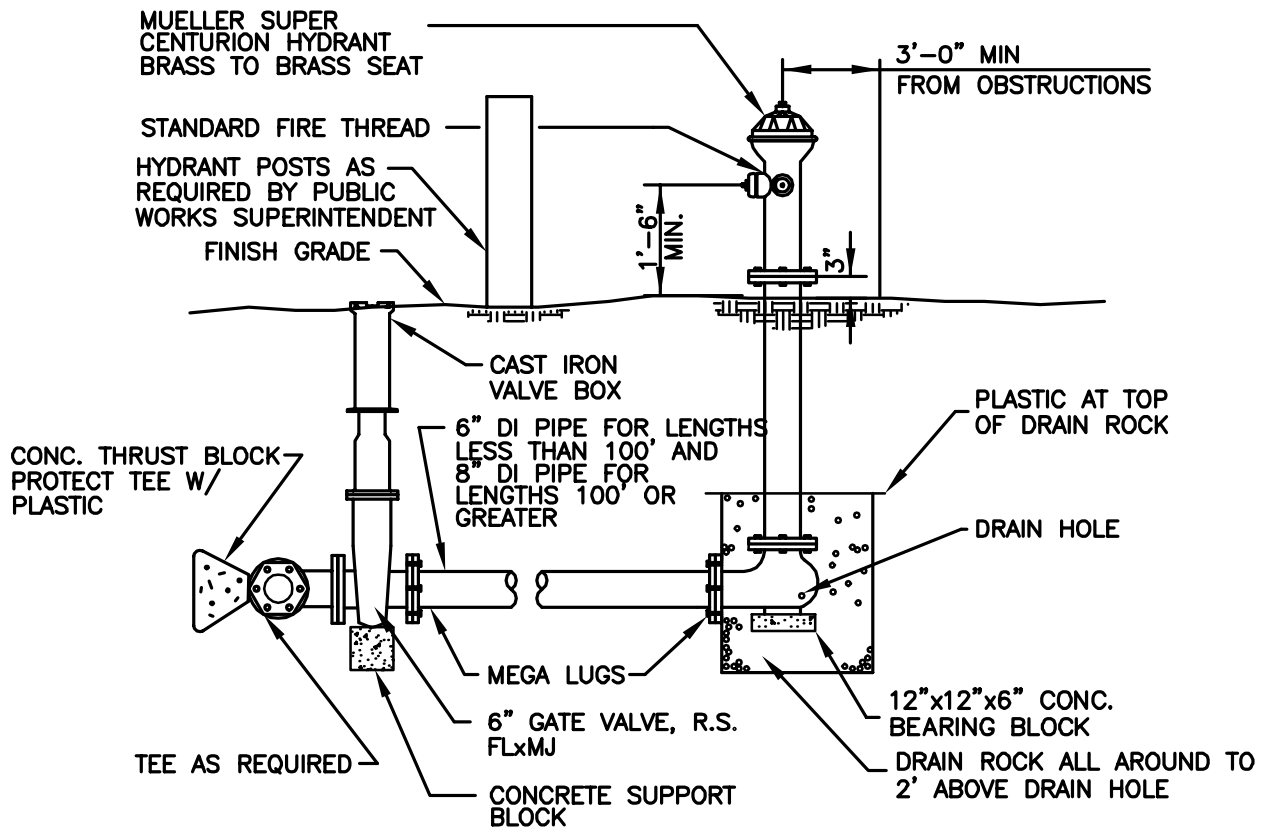

**NOTE:**

1. DO NOT COVER DRAIN HOLE.
2. THE CONTRACTOR SHALL FURNISH AND INSTALL A 2'x2'x4" THICK CEMENT CONCRETE PAD AROUND EACH VALVE BOX NOT ALREADY SITUATED WITHIN A PAVED ROADWAY

**FIRE HYDRANT DETAIL**

NTS



**CITY OF OKANOGAN**  
Fire Hydrant Detail

REVISION DATE:  
3/30/07

SCALE:  
NONE

DWG. NO.  
WT-4

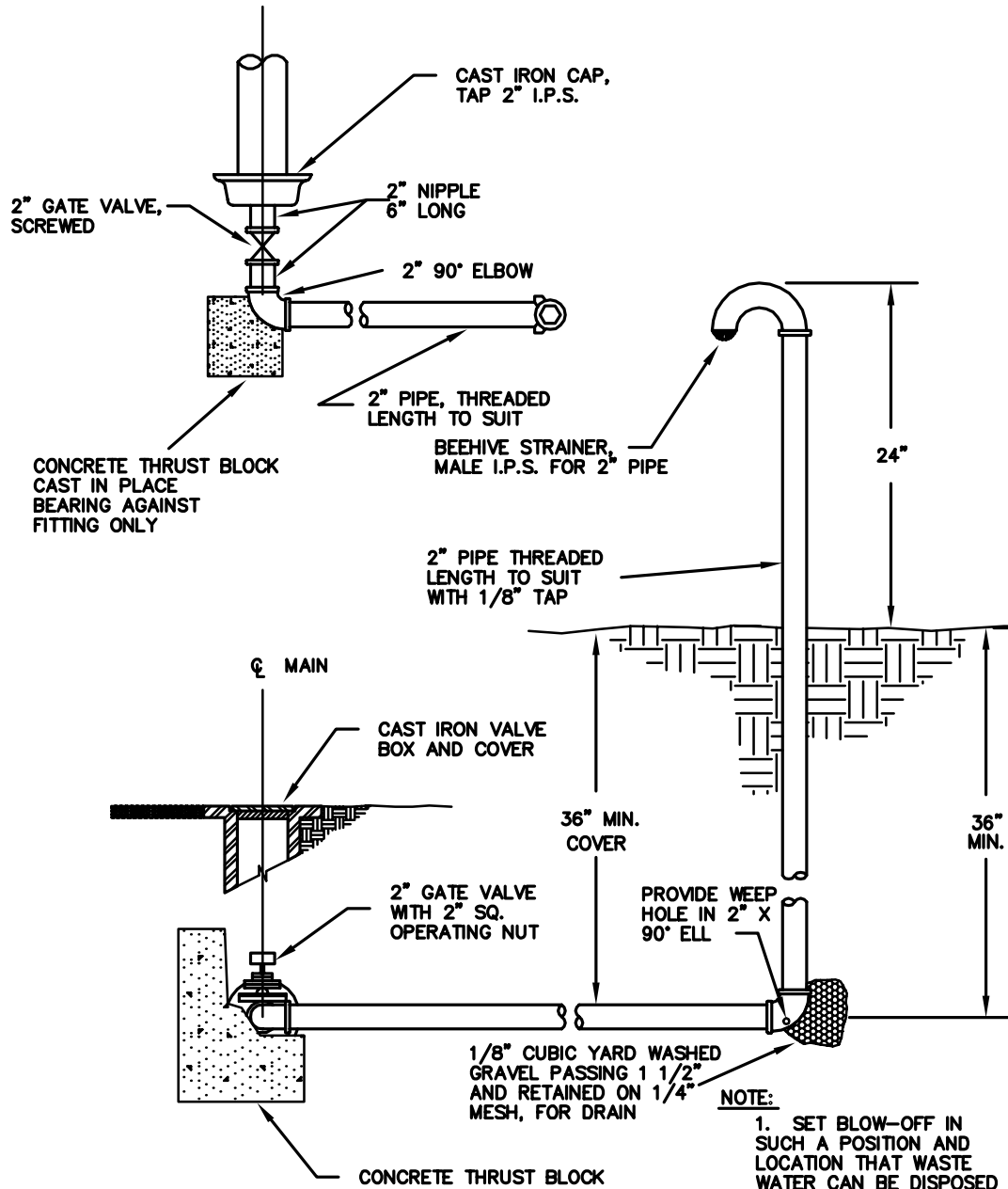

## **TYPE I BLOW-OFF ASSEMBLY**

NTS



**CITY OF OKANOGAN**  
Type 1 Blow-Off  
Assembly

REVISION DATE:  
3/30/07

SCALE:  
NONE

DWG. NO.  
WT-5

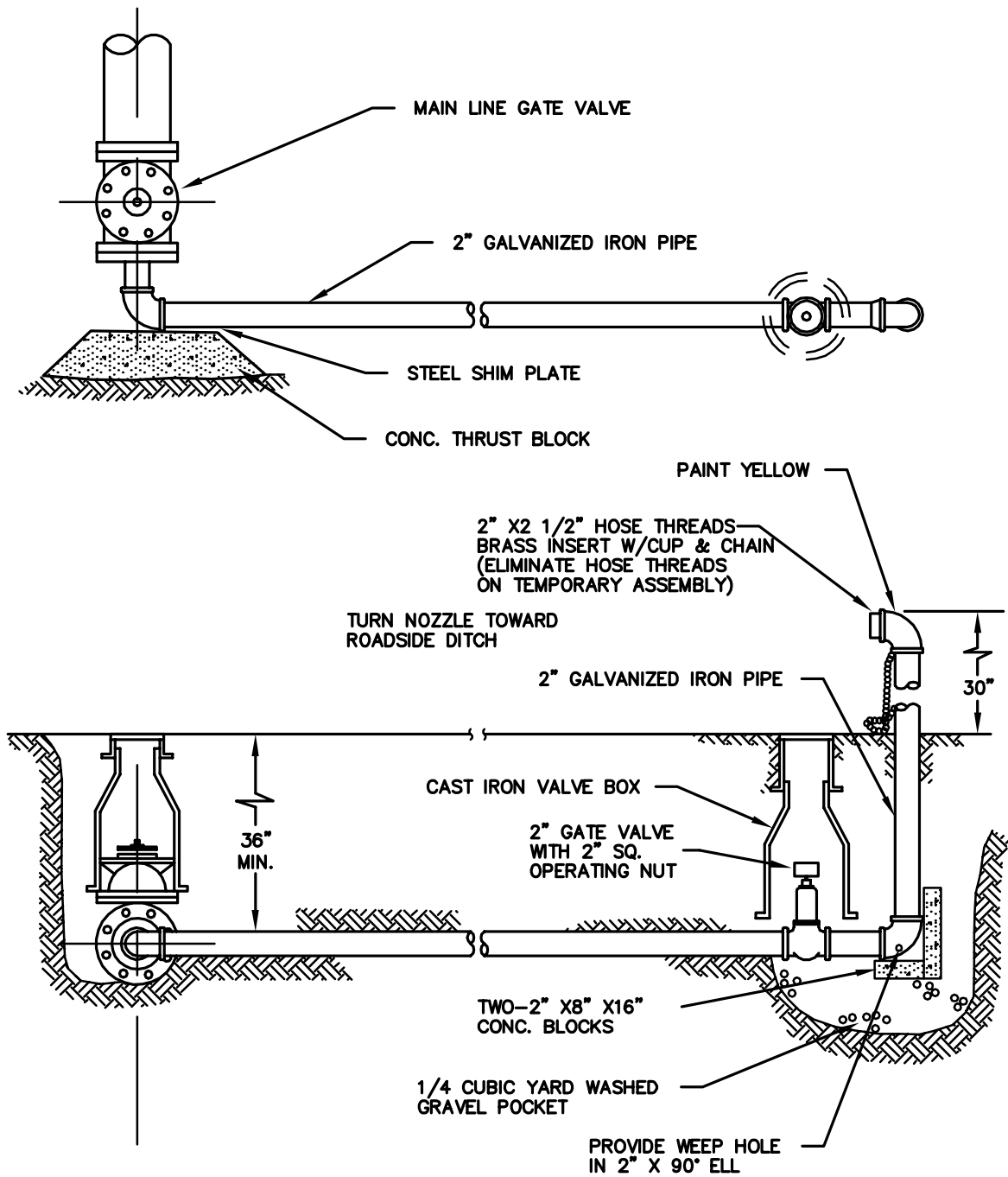

**TYPE II BLOW-OFF ASSEMBLY**

NTS



CITY OF OKANOGAN

Type 2 Blow-Off  
Assembly

REVISION DATE:  
3/30/07

SCALE:  
NONE

DWG. NO.  
WT-6

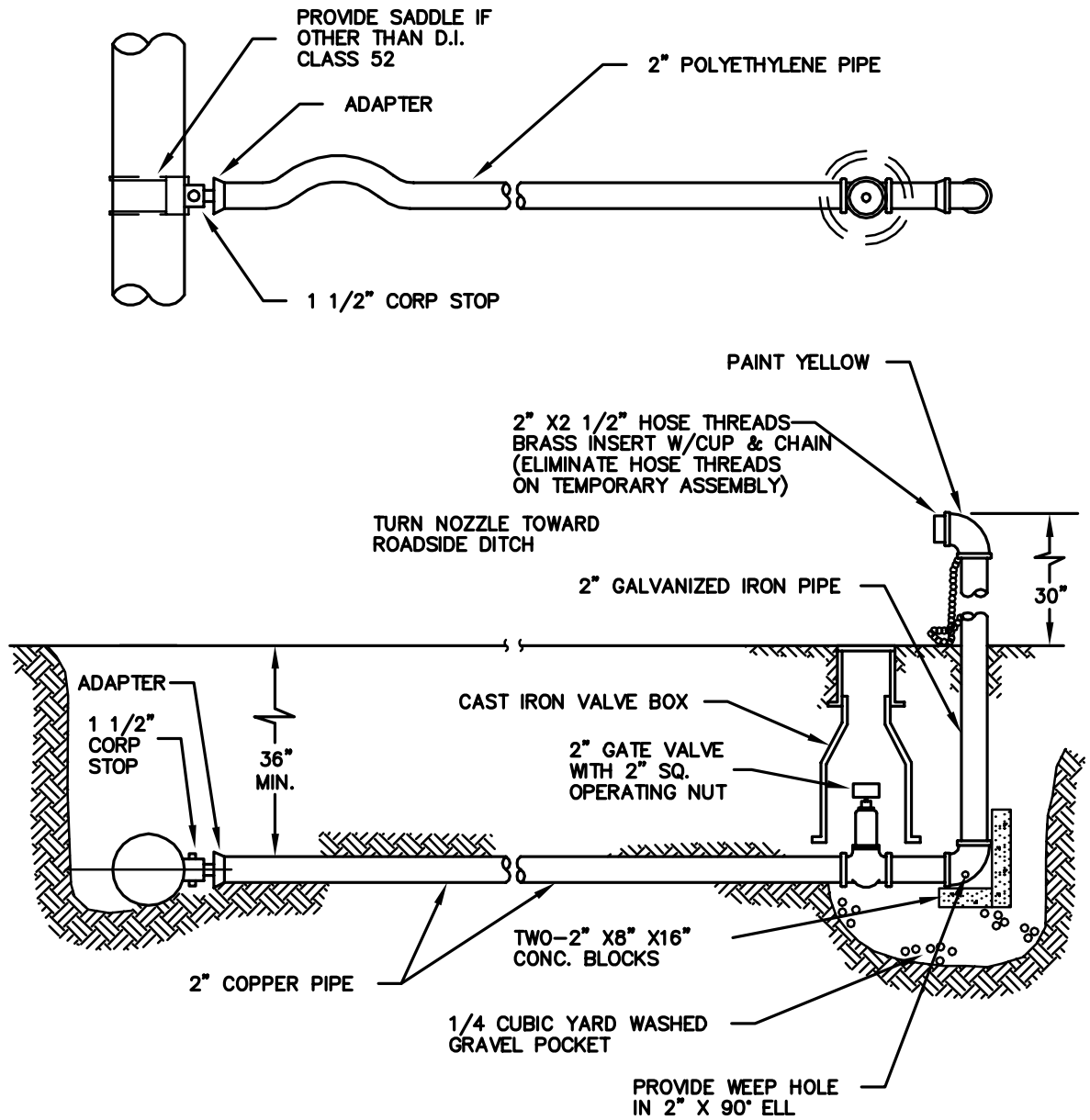

**TYPE III BLOW-OFF ASSEMBLY**

NTS



CITY OF OKANOGAN  
Type 3 Blow-Off  
Assembly

REVISION DATE:  
3/30/07

SCALE:  
NONE

DWG. NO.  
WT-7

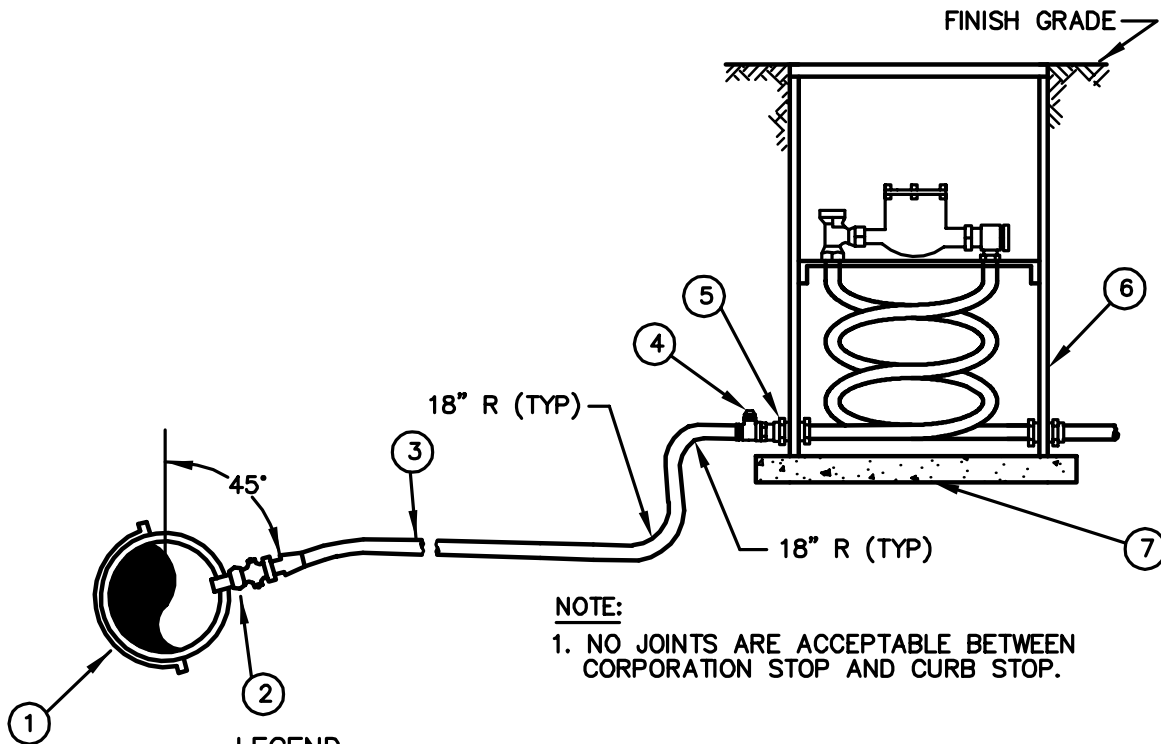

**NOTE:**

1. NO JOINTS ARE ACCEPTABLE BETWEEN CORPORATION STOP AND CURB STOP.

**LEGEND**

- ① ROMAC SADDLE SINGLE STRAP FOR PIPE DIAMETERS LESS THAN 10" AND DOUBLE STRAP FOR PIPE DIAMETERS 12" AND GREATER.
- ② 1" SERVICE-1" MIP x CTS-PE CORP STOP (MUELLER B-25028N)  
2" SERVICE-2" MIP x CTS-PE CORP STOP (MUELLER B-25028N)
- ③ 1" SERVICE-1" POLYETHYLENE SERVICE LINE 200PSI (LENGTH AS REQUIRED)  
2" SERVICE-2" POLYETHYLENE SERVICE LINE 200PSI (LENGTH AS REQUIRED)
- ④ 1" SERVICE-1" FORD BALL VALVE CURB STOP (B41-444G)  
2" SERVICE-2" FORD BALL VALVE CURB STOP (B41-777G)
- ⑤ 1" SERVICE-1" X 3/4" BRASS COUPLING  
2" SERVICE-2" FORD STRAIGHT METER COUPLING (C38-77-3.0625)
- ⑥ 5/8"x3/4" MUELLER THERMAL COIL METER BOX #203CS1548LBBN WITH MUELLER 3/4" FLAT NO LOCK LID (#790007) AND 15" MUELLER INSULATING PAD (#790162), 2" THICKNESS
- ⑦ 2- 1.5"x8"x16" CONCRETE "PATIO" BLOCKS

**TYPE 1 WATER SERVICE CONNECTION DETAIL**

NTS

	<b>CITY OF OKANOGAN</b> Type 1 Water Service Connection	
	REVISION DATE: 3/30/07	SCALE: NONE



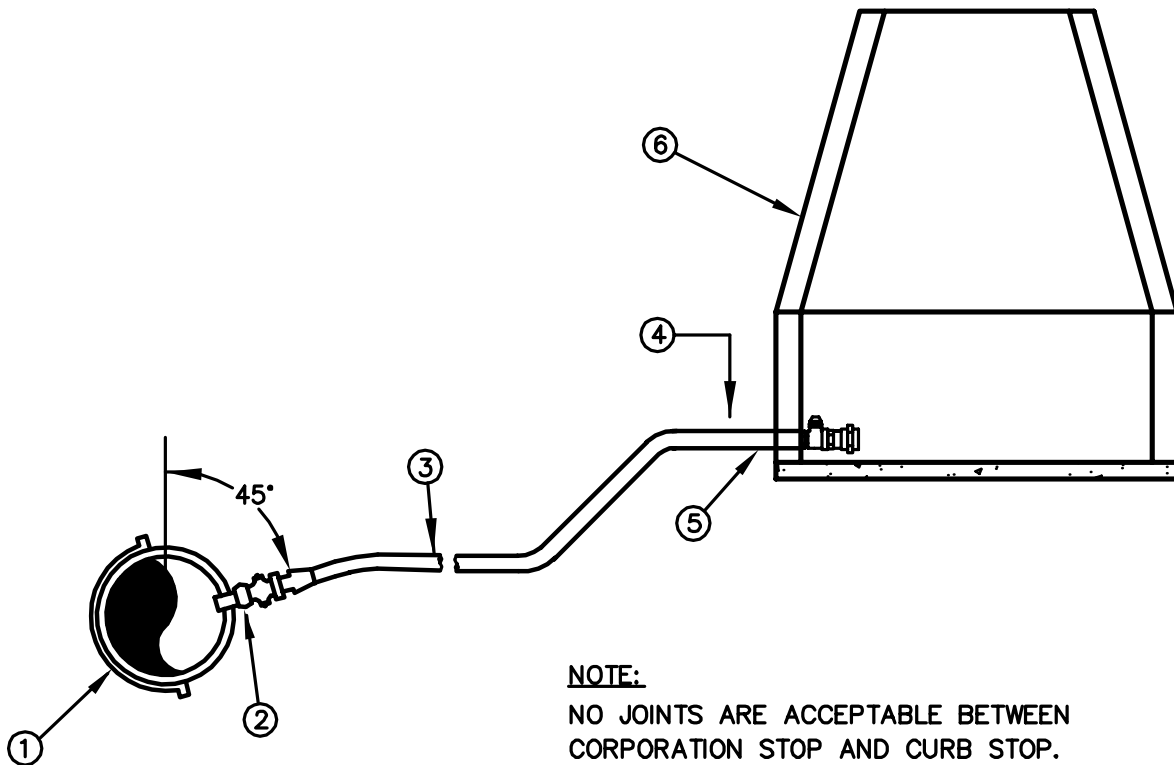

**LEGEND**

- ① ROMAC SADDLE SINGLE STRAP FOR PIPE DIAMETERS LESS THAN 10" AND DOUBLE STRAP FOR PIPE DIAMETERS 12" AND GREATER.
- ② 1" SERVICE-1" MIP x CTS-PE CORP STOP (MUELLER B-25028N)  
2" SERVICE-2" MIP x CTS-PE CORP STOP (MUELLER B-25028N)
- ③ 1" SERVICE-1" POLYETHYLENE SERVICE LINE 200 PSI (LENGTH AS REQUIRED)  
2" SERVICE-2" POLYETHYLENE SERVICE LINE 200 PSI (LENGTH AS REQUIRED)
- ④ 1" SERVICE-1" FORD BALL VALVE CURB STOP (B41-444G)  
2" SERVICE-2" FORD BALL VALVE CURB STOP (B41-777G)
- ⑤ 1" SERVICE-1" FORD STRAIGHT METER COUPLING (C38-44-2.625)  
2" SERVICE-2" FORD STRAIGHT METER COUPLING (C38-77-3.0625)
- ⑥ 1- H2 PRECAST WATER METER CHAMBER (WCB,WCT) WITH CAST IRON METER LID (2019)

**TYPE 2 WATER SERVICE CONNECTION DETAIL**

NTS



**CITY OF OKANOGAN**  
Type 2 Water  
Service Connection

REVISION DATE:  
3/30/07

SCALE:  
NONE

DWG. NO.  
WT-9

NOTE:  
 IN GENERAL, THE CITY'S CROSS CONNECTION CONTROL SPECIALIST REQUIRES AN AIR GAP OR ATMOSPHERIC VACUUM BREAKER ON IRRIGATION CONNECTIONS. TO PROTECT AGAINST FROST, DCVA INSTALLATIONS MUST BE COMPLETELY DRAINED IN THE WINTER.

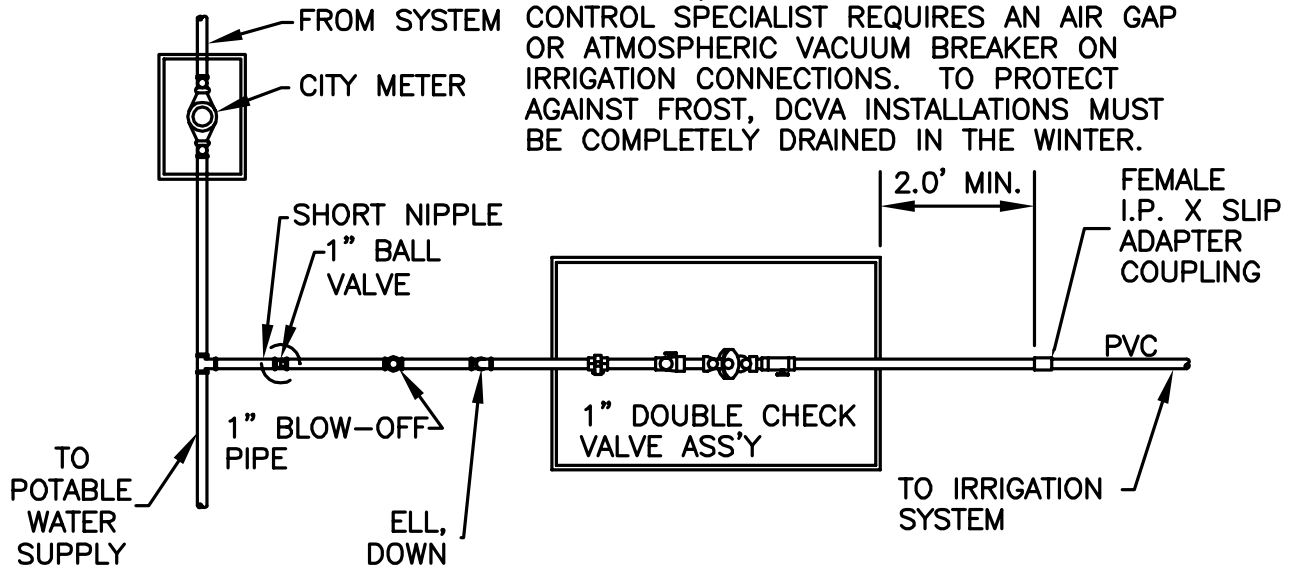

**PLAN**

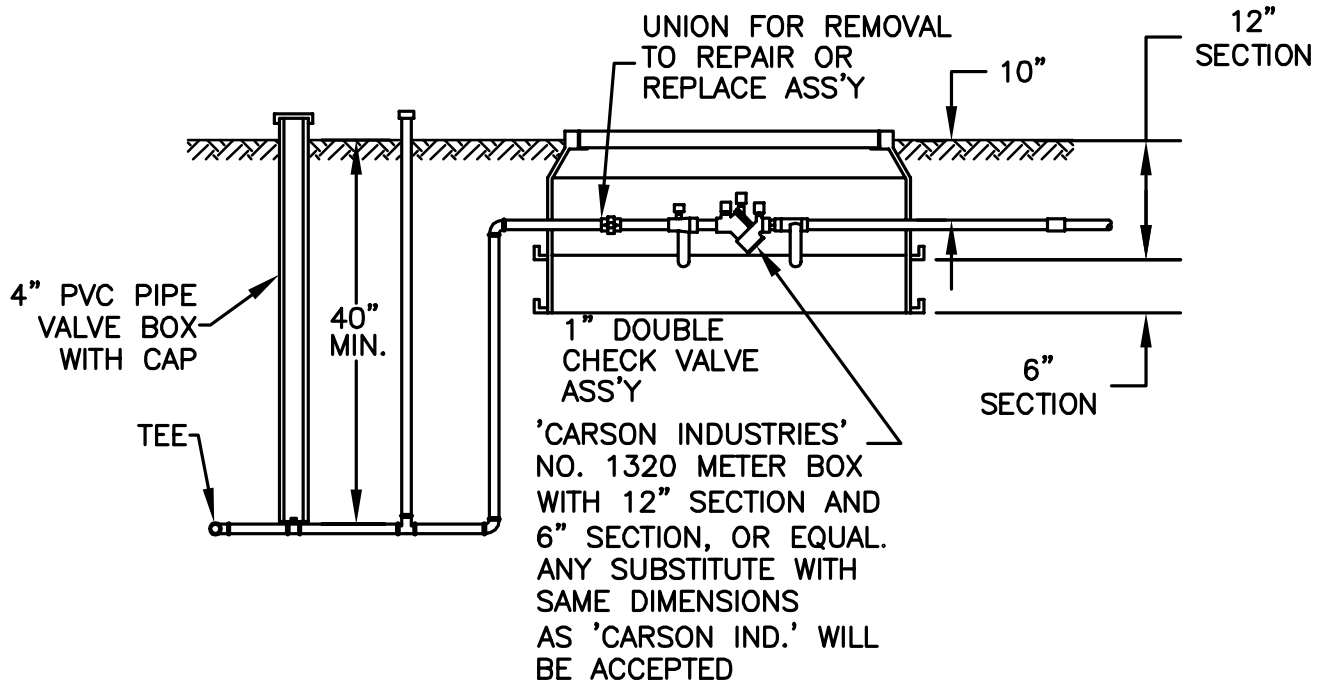

**SECTION**

\*- SEE ATTACHED FOR APPROVAL OF DOUBLE CHECK VALVE ASS'Y AND TESTING AND MAINTANANCE OF ASS'Y. DOUBLE CHECK VALVES LARGER THAN 1" WILL REQUIRE DISGN SUBMITTAL AND APPROVAL BY THE CITY PUBLIC WORKS SUPERINTENDANT.

	<b>CITY OF OKANOGAN</b> 1-inch Double Check Valve	
	REVISION DATE: 3/30/07	SCALE: NONE

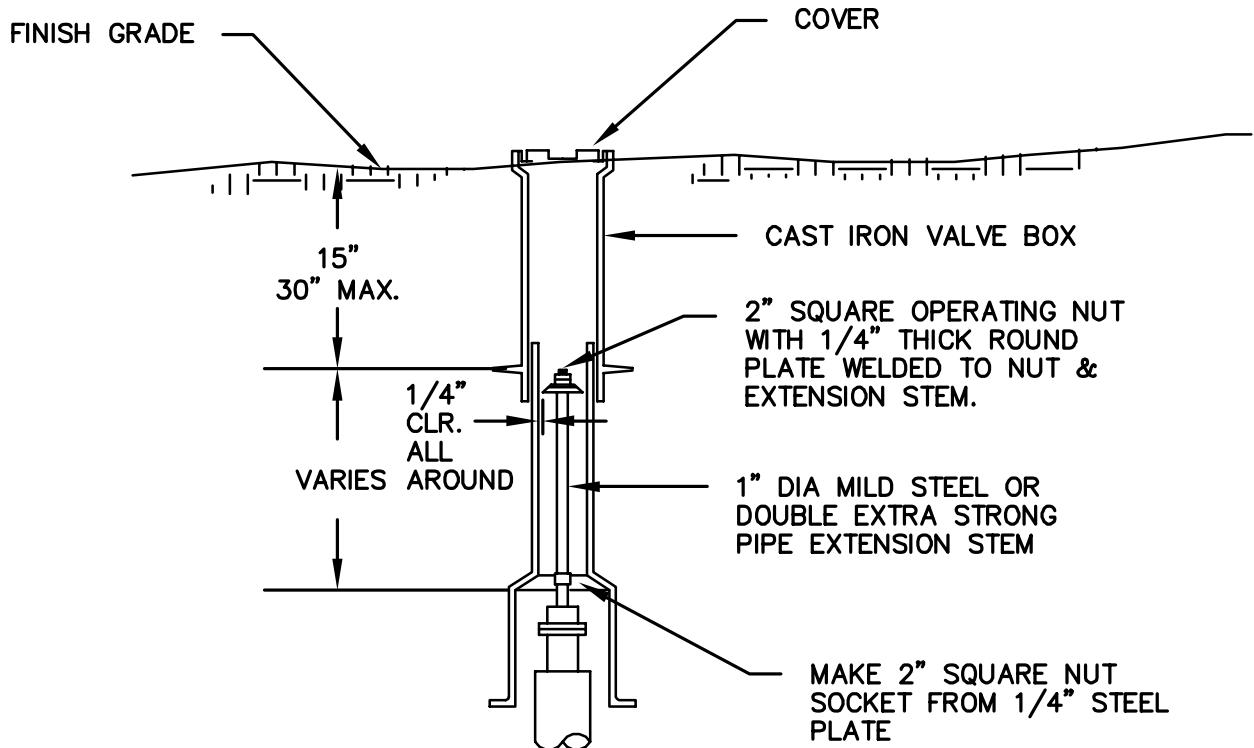

## **VALVE STEM EXTENSION DETAIL**

NTS



CITY OF OKANOGAN  
Valve Stem  
Extension Detail

REVISION DATE:  
3/30/07

SCALE:  
NONE

DWG. NO.  
WT-11

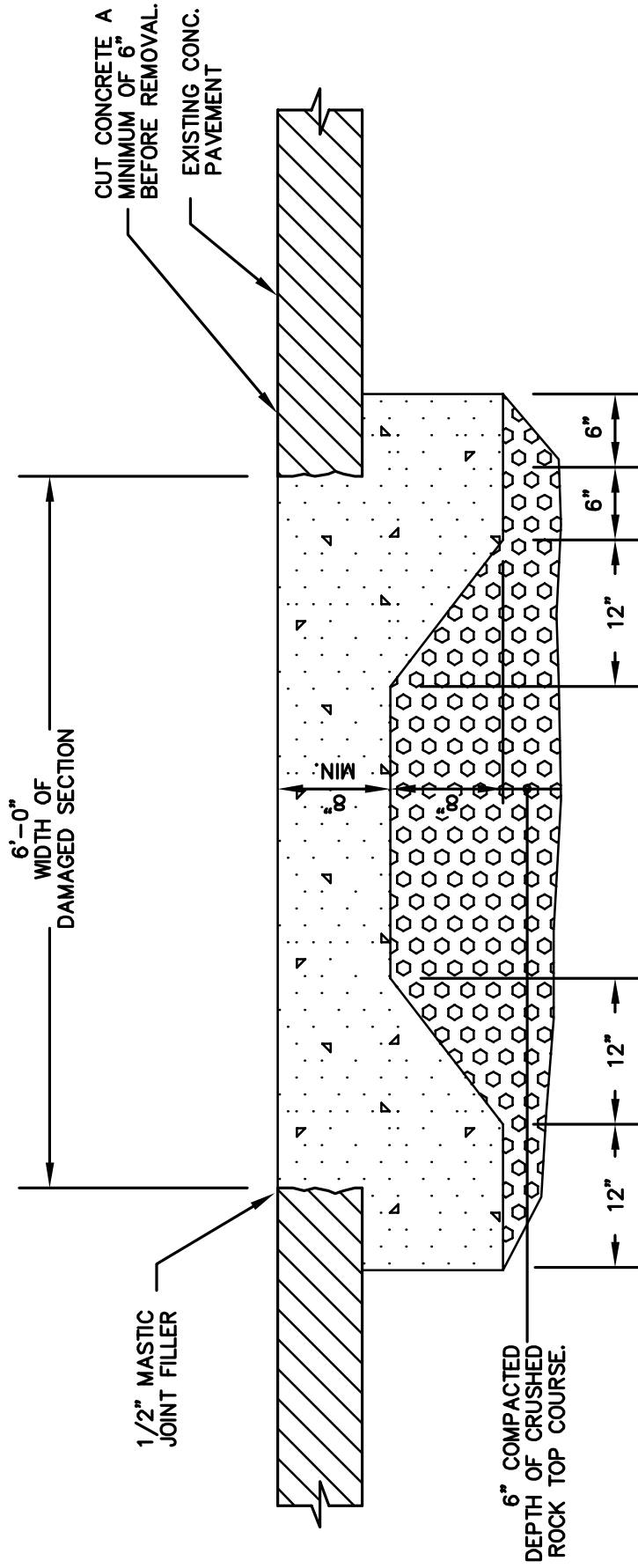

**CEMENT CONCRETE PAVEMENT REPAIR**

NTS

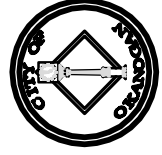

CITY OF OKANOGAN  
Cement Concrete  
Pavement Repair

REVISION DATE: 3/30/07  
SCALE: NONE

DWG. NO. **WT-12**

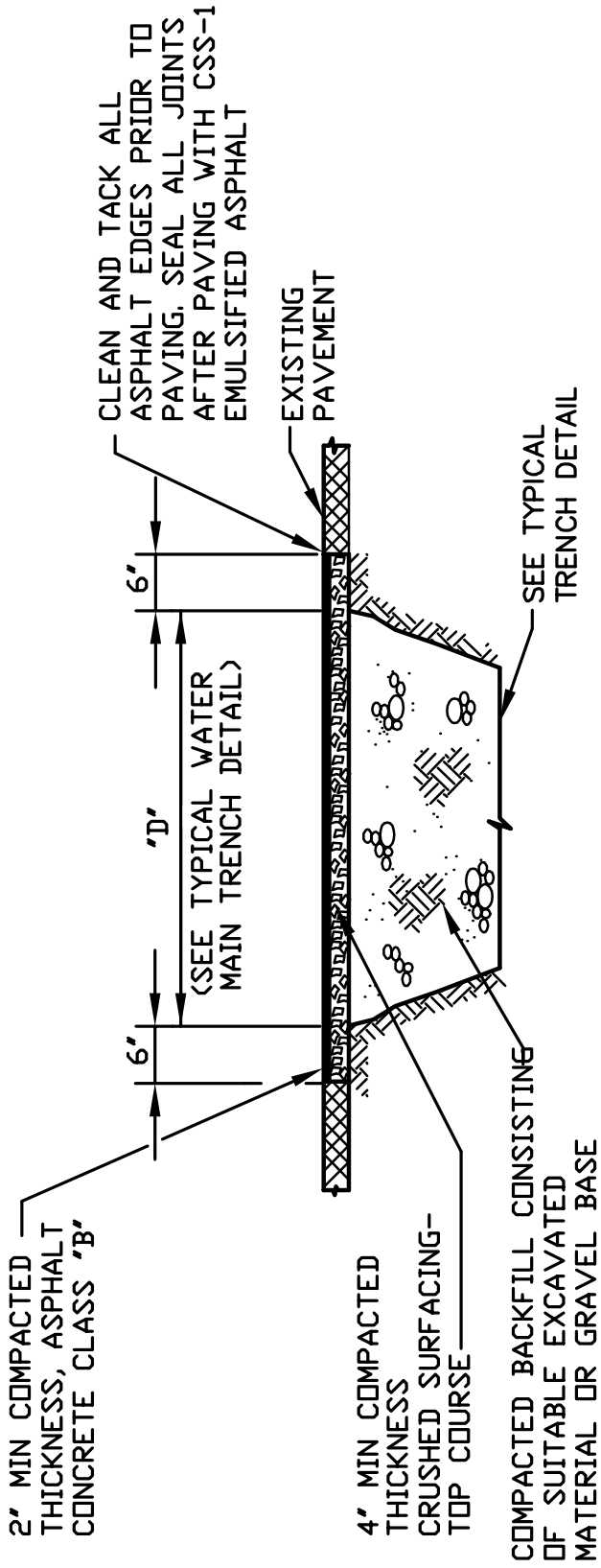

# **ASPHALT PAVEMENT REPAIR** **WITHOUT OVERLAY**

NTS

CITY OF OKANOGAN

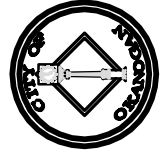

CITY OF OKANOGAN  
Asphalt Pavement  
Repair Without Overlay

REVISION DATE:

SCALE:

DWG. NO.

3/30/07

NONE

**WT-13**

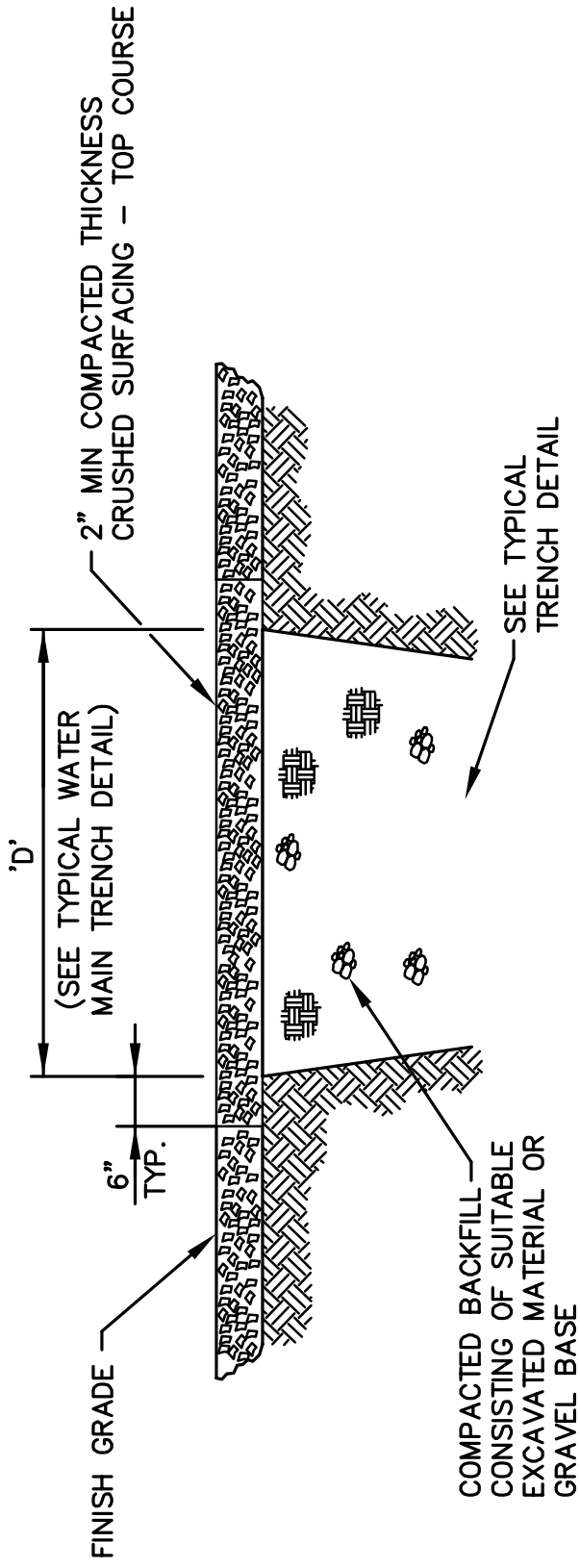

# GRAVEL REPAIR DETAIL

NTS

CITY OF OKANOGAN

STANDARD PLAN NO.14  
GRAVEL REPAIR  
DETAIL



CITY OF OKANOGAN

## Gravel Repair Detail

REVISION DATE:

SCALE:

DWG. NO.

3/30/07

NONE

**WT-14**



10' WIDTH OF 2" MESH GALVANIZED CHICKEN WIRE LAID OVER STRAW AND STAPLED TO 2" X 2" STAKES

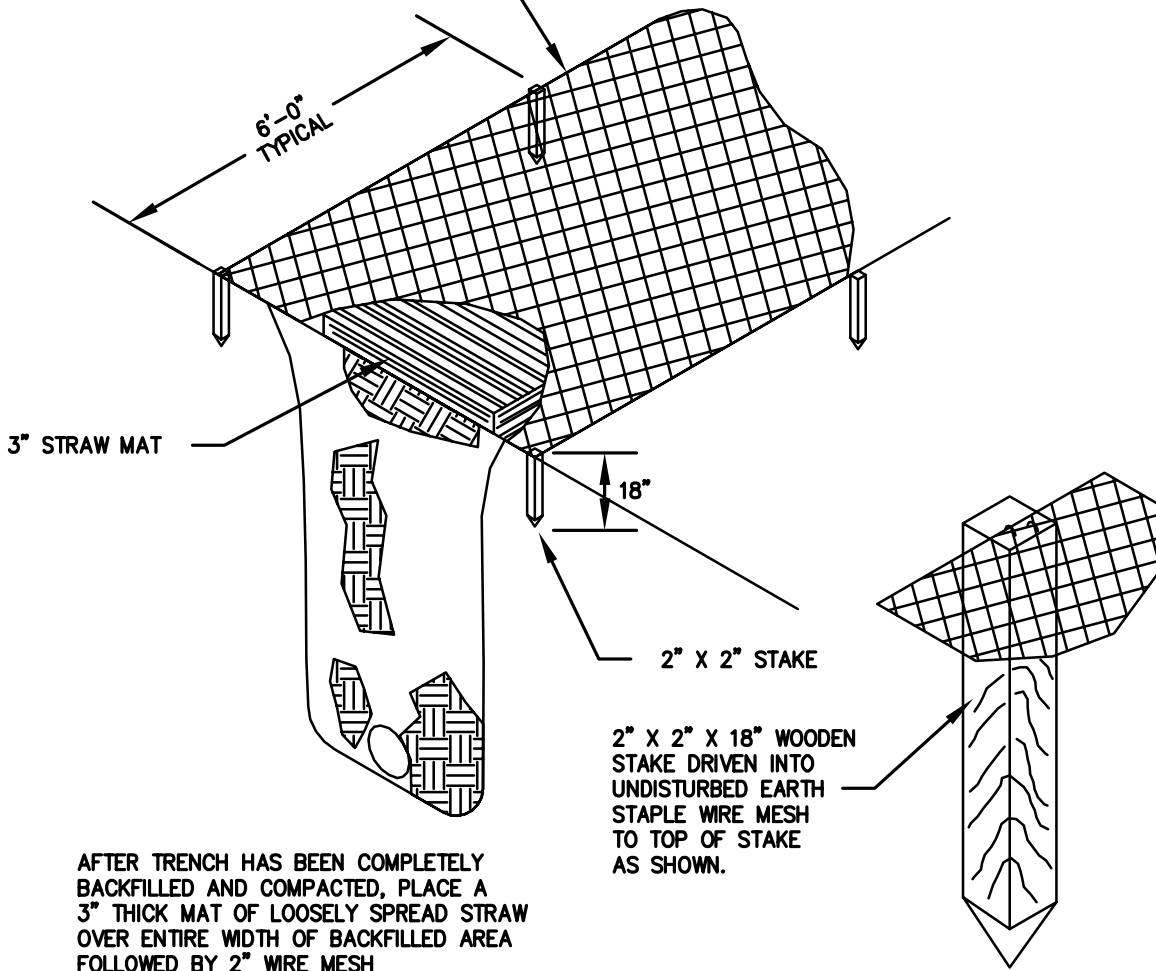

AFTER TRENCH HAS BEEN COMPLETELY BACKFILLED AND COMPACTED, PLACE A 3" THICK MAT OF LOOSELY SPREAD STRAW OVER ENTIRE WIDTH OF BACKFILLED AREA FOLLOWED BY 2" WIRE MESH

WIRE MESH FOR SLOPE PROTECTION SHALL BE USED WHEN SO DIRECTED BY THE DISTRICT AND/OR ENGINEER.

THIS SLOPE PROTECTION DETAIL REPRESENTS MIN. REQUIREMENTS FOR MATERIALS AND INSTALLATION.

## **SLOPE PROTECTION DETAIL**

NO SCALE



**CITY OF OKANOGAN**  
Slope Protection  
Detail

REVISION DATE:  
3/30/07

SCALE:  
NONE

DWG. NO.  
WT-15

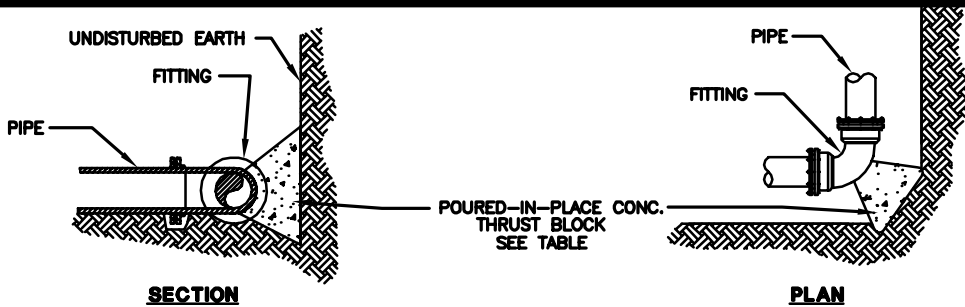

**SECTION**

**PLAN**

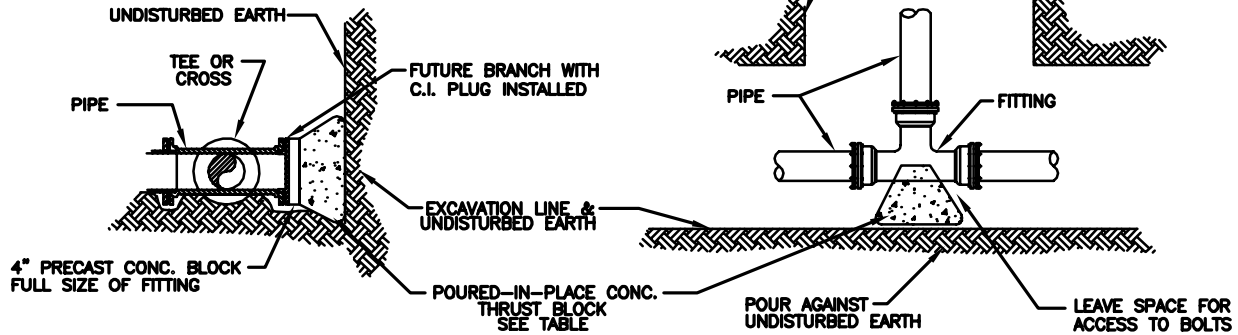

**SECTION**

**PLAN**

PIPE SIZE	11-1/4" BEND	22-1/2" BEND
6"	0.5 CY	1.0 CY
8"	1.0 CY	1.5 CY
12"	1.5 CY	3.0 CY

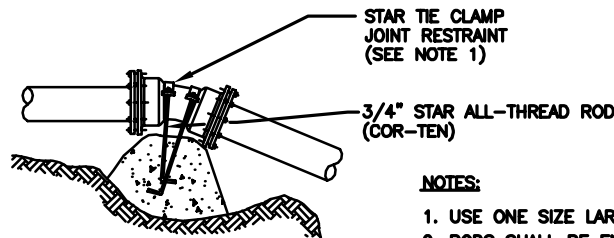

**NOTES:**

1. USE ONE SIZE LARGER THAN NOMINAL SIZE
2. RODS SHALL BE EMBEDDED 2 FT. INTO CONCRETE.

PIPE SIZE	11-1/4" BEND	22-1/2" BEND
6"	0.5	1
8"	1	1.5
12"	1.5	3

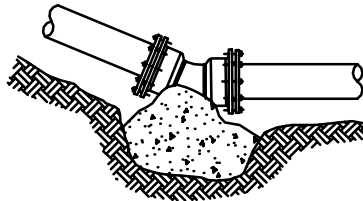

**VERTICAL SECTIONS**

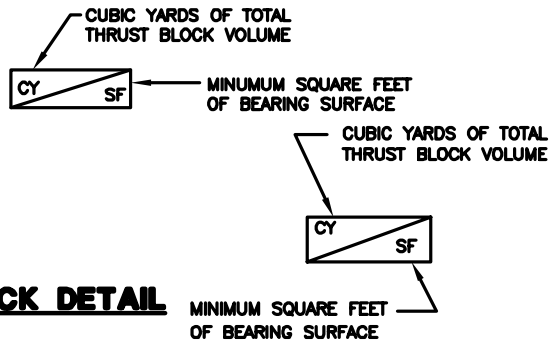

**CONCRETE THRUST BLOCK DETAIL**

NTS

**CONCRETE THRUST BLOCK - SIZE DETAILS**

PIPE SIZE	11-1/4" BEND	22-1/2" BEND	45° BEND	90° BEND	TEE OR PLUG
6"	1/4 3	1/3 3.5	1/2 4	2/3 4.5	1/2 4
8"	1/3 6	1/2 6	2/3 6.5	3/4 8	2/3 6.5
12"	1 12	1 12	1-1/4 15	2 16	1-1/4 15

**NOTE:**  
ECOLOGY BLOCKS ARE UNACCEPTABLE THRUST RESTRAINTS

\* FIRE HYDRANT

**NOTE:**  
PLACE VISQUEEN SHEET SO CONCRETE THRUST BLOCK IS NOT POURED DIRECTLY AGAINST FITTINGS. PROVIDE VISQUEEN BONDBREAK.



**CITY OF OKANOGAN**  
Concrete Thrust Block

REVISION DATE:  
3/30/07

SCALE:  
NONE

DWG. NO.  
WT-16

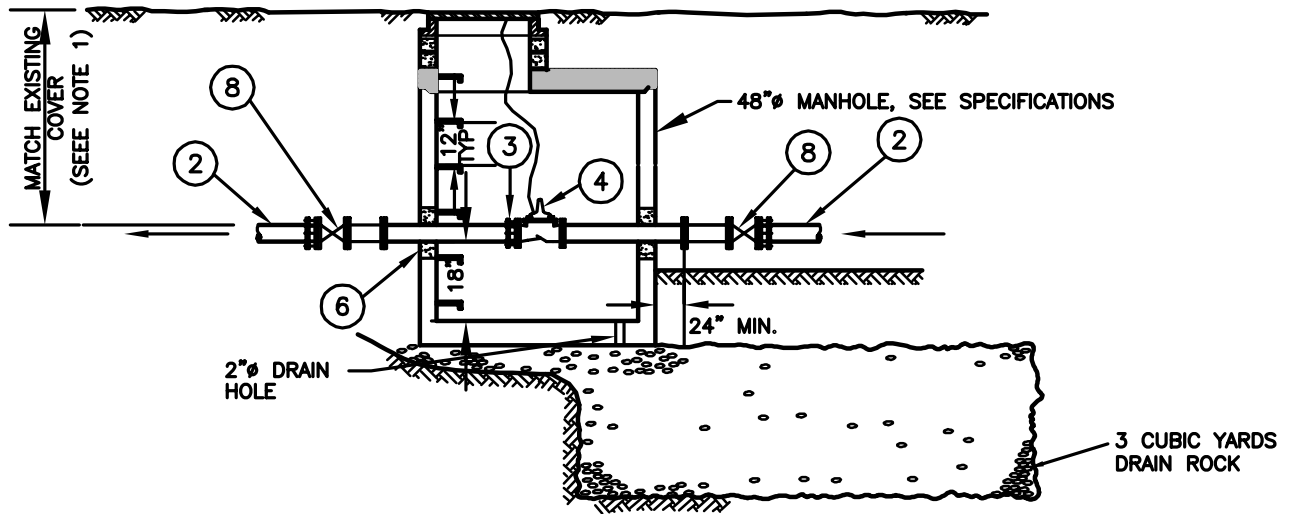

### 3" METER INSTALLATION

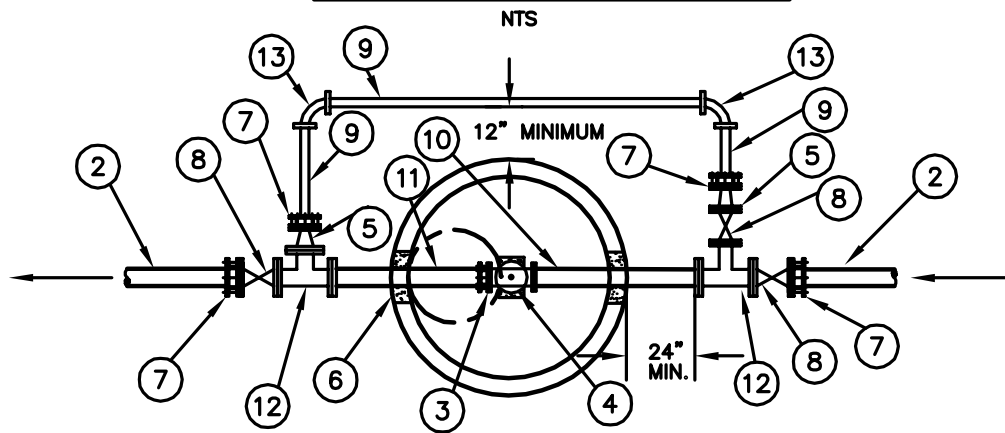

### PLAN

NTS

#### ITEM DESCRIPTION

- ① RECORD DRAWINGS INDICATE MOST SERVICE LINES HAVE APPROXIMATELY 5' OF COVER. THE CONTRACTOR SHALL VERIFY ACTUAL DEPTH OF SERVICE LINES IN THE FIELD.
- ② EXISTING 3" SERVICE LINE
- ③ 3" FLANGED COUPLING ADAPTER
- ④ 3" METER, FLxFL, TO BE CENTERED IN MANHOLE
- ⑤ 3"x2" D.I. REDUCER, FLxFL
- ⑥ NON-SHRINK GROUT, TYP.
- ⑦ 3" INSULATED FLxMJ ADAPTER
- ⑧ 3" D.I. GATE VALVE, FLxFL, SEE TYPICAL BURIED VALVE DETAIL
- ⑨ 2" GALVANIZED IRON BYPASS LINE
- ⑩ 3" DUCTILE IRON MAINLINE SPOOL, FLxFL, CONTRACTOR TO FIELD VERIFY LENGTH
- ⑪ 3" DUCTILE IRON MAINLINE SPOOL, FLxPE, CONTRACTOR TO FIELD VERIFY LENGTH
- ⑫ 3"x3"x3" D.I. TEE, FLxFLxFL
- ⑬ 2" GALVANIZED ELBOW

#### NOTE:

FOR METER INSTALLATIONS LARGER THAN 3", SERVICE LINE AND BYPASS LINE SIZE SHALL BE AS DETERMINED BY THE PUBLIC WORKS DIRECTOR.

99021\3IN-METER



CITY OF OKANOGAN  
3" & Larger Water  
Service Connection

REVISION DATE:  
3/30/07

SCALE:  
NONE

DWG. NO.  
WT-17

# **CITY OF OKANOGAN**

## **STANDARD PLAN NO. 10**

### **APPROVAL OF ASSEMBLIES**

The term “Approval Assembly” shall mean any backflow prevention assembly that has satisfactorily completed laboratory and field tests by an independent laboratory recognized by the State of Washington Department of Health. Backflow devices shall be of the correct type as required by the Public Works Superintendent and be selected from the State of Washington approved list.

### **TESTING AND MAINTENANCE OF ASSEMBLIES**

Each backflow prevention assembly shall be tested to insure that it functions properly annually; upon installation; after repairs; and after being relocated, moved, or reinstalled.

The assembly owner shall be notified prior to the date for annual testing. It is then the assembly owner’s responsibility to acquire the services of a certified tester to test the assembly. If the test indicates the assembly must be repaired, a record of the repair work and a report of a satisfactory final test must be sent to the City of Okanogan (see “Backflow Prevention Assembly Test Report Form” in the AWWA Cross Connection Control Manual).

The annual testing of backflow prevention assemblies must be done prior to any repair work or flushing of the relief valve to properly establish its operating status. Failure to test and maintain backflow prevention assemblies is grounds for the City to discontinue water service.

## CHAPTER 8

### CAPITAL IMPROVEMENT PROGRAM

Various improvement projects were identified in Chapter 3. A brief description of each project selected for the 6-year and 20-year planning horizons is presented in this chapter. A map showing the location of each project is presented on Figure 8-1. Detailed cost estimates are provided in Appendix L. A schedule for implementing the 6-year planned improvements is provided in Table 8-1 at the end of this chapter. Approaches to financing the improvements planned for the next six years are discussed in Chapter 9.

#### WATER RIGHTS

The City plans to file change applications with the Washington State Department of Ecology to consolidate its existing water rights to give the City greater flexibility in managing its water resources.

The City includes areas within the boundaries of the Confederated Tribes of the Colville Reservation (CTCR). The City plans to work with the CTCR to review and coordinate water rights applications as deemed beneficial to preserve, enhance and support predictable growth within this area of joint planning jurisdiction.

#### AGREEMENTS

The City plans to review its agreement for the delivery of water for domestic use to the Progressive Flats Water Association.

#### TELEMETRY

The City has identified the following telemetry system improvements for its 6-year improvement schedule:

1. **Telemetry System Improvements** – The City plans to upgrade the existing telemetry control system with a new base station master computer, PLC at the base station master computer, HMI software, and new programming in order to increase reliability and to add functionality. The new system will control reservoir levels, record data and have the capability of performing additional functions for anticipated needs, such as chlorine residual monitoring at each well site and flow metering of the water delivered to the Progressive Flats Water Association, and to include flow metering from all sources and telemetry for the new Murray Street Booster Pump Station (**6-year plan**).

## SOURCE IMPROVEMENTS

The City has identified the following source improvements for its 6- and 20-year improvement schedule:

2. **Watercress Springs Feasibility Study** – Feasibility study to investigate required improvements and costs to rehabilitate the Watercress Springs source, storage and water distribution system (**6-year plan**).
3. **Well Improvements** - Install manual transfer switches, motor soft starts and provide ports for groundwater depth measurements at Wells No. 2, 3, 4, and 5 and one portable standby generator capable of serving any of these wells. (**6-year plan**).
4. **Well Decommissioning** – Decommission old City Well No. 1, old Well No. 4, and an old well discovered on City property at the Okanogan Sports Complex (**6-year plan**).
5. **Well No. 3 Inspection** – Remove submersible turbine pump and perform video inspection of Well No. 3 (**6-year plan**).
6. **Well No. 4 Bypass** – Bypass piping improvements at Well No. 4 (**6-year plan**).
7. **Well No. 6 (Riverwalk Well)** - Investigate feasibility to develop the privately-owned Well No. 6 (Riverwalk Well). This improvement would replace the 48-foot deep well with a new 12” diameter well constructed to municipal standards (**20-year**).

## TREATMENT

The City has identified the following treatment improvements for its 6- and 20-year improvement schedule:

8. **Arsenic Treatment Facility Feasibility Study** – Feasibility study to investigate alternatives and make recommendations for the collection and disposal of arsenic-laced sludge from the arsenic treatment facility (**6-year plan**).
9. **Arsenic Treatment Facility Improvements** – Construct sludge collection and disposal facilities in accordance with the findings and recommendations of the arsenic treatment facility feasibility study (**6-year**).
10. **Well Chlorination Improvements** - Install chlorination facilities at the City’s active well sites (**20-year plan**).



## STORAGE

The City has identified the following storage-related improvements for its 20-year improvement schedule:

11. **Murray Reservoir** - Construct 200,000-gallon reservoir in the Murray pressure zone. The project includes construction of a transfer station for water transfer to the lower zone, as necessary; pressure reducing valve stations in order to provide adequate service throughout the pressure zones; approximately 5,000 feet of 12” PVC C900 water main, valves and appurtenances. These improvements are needed to provide adequate pressures and fire suppression storage for the Murray pressure zone as well as provide additional fire suppression storage for the Lower pressure zone. **(20-year plan)**.
12. **West Reservoirs Improvements** - Install security fencing and gates to limit access to the West reservoirs and replace the existing wood-frame truss roof on West Reservoir No. 1 **(20-year plan)**.
13. **East Reservoir Improvements** - Clean and inspect the East Reservoir and install a center fill pipe (similar to the North Reservoir) to improve mixing **(20-year plan)**.

## DISTRIBUTION

The City has identified the following distribution system improvements for its 6- and 20-year improvement schedule:

14. **Murray Street Master Meter** – Demolish the existing building and install the master meter in a vault **(6-year plan)**.
15. **Murray Street Booster Pump Station** – Construct new Murray Street booster pump station capable of serving future Murray Reservoir, including two booster pumps with pitless adapters, building for electrical and control equipment, including variable frequency drive motors **(6-year plan)**.
16. **5<sup>th</sup> Avenue Water Main Replacement** – This improvement consists of the replacement of the existing 6” CI water line with a new 12” water line on 5<sup>th</sup> Avenue from Spruce Street to Oak Street **(6-year plan)**.
17. **Elmway Water Main Extension (Phase 3)** – This improvement consists of the construction of a new 12” water line on 2<sup>nd</sup> Avenue (SR 215) from River Street to Shell Rock Point to extend municipal water service to the City’s northern city limits and eventual connection (at a location to be determined) with the North River Crossing **(6-year plan)**.

18. **1<sup>st</sup> Avenue Water Main** – This improvement consists of the replacement of the existing 6” AC water line with a new 8” water line on 1<sup>st</sup> Avenue from Ione Street to Conconully Street and the construction of a new 8” water line from Conconully Street to Tyee Street to provide system looping (**6-year plan**).
19. **South Okanogan Water System Improvements** – This improvement consists of the replacement of existing 6” water lines on Ione Street, Gordon Street, 2<sup>nd</sup> Avenue, Nickell Street, and at the entrance to the City’s wastewater treatment plant, with new 8” and 12” water lines to improve fire flow in these areas (**6-year plan**).
20. **Rodeo Trail Water Main Replacement** – This improvement consists of the replacement of existing 2 ½” and 8” water lines on Rodeo Trail with a new 12” water line and extension to the Central Valley Sports Complex to improve fire flows in this area and provide for future expansion to the north (**6-year plan**).
21. **Highland Drive Water Main Replacement** – This improvement consists of the replacement of existing 2 ½” GI water pipe on Highland Drive and east to Richlyn Avenue with new 8” water main to improve fire flows in this area (**6-year plan**).
22. **Tacoma Street/Spokane Street Water Main Loop** – This improvement consists of the replacement of existing 4” AC and CI water pipe with new 8” water lines on Tacoma Street, 4<sup>th</sup> Avenue, and Spokane Street to improve fire flows in this area (**6-year plan**).
23. **2nd Avenue South Water Main Replacement** – This improvement consists of the replacement of existing 6” AC and DI water main pipe on 2<sup>nd</sup> Avenue from Ione Street to Rose Street with new 8” water main (**20-year plan**).
24. **Viewmont Drive Water Main Replacement** – This improvement consists of the replacement of the existing 6” AC water main on Viewmont Drive from Highland Drive to Crestview Drive with new 8” water main pipe and the extension of 8” water main on Delmav to Crestview Drive to improve fire flows in the area, provide looping on Delmav, and improve water transmission to the central grid from the Highland Reservoir (**20-year plan**).
25. **3<sup>rd</sup> Avenue North Water Main Replacement** – This improvement consists of the replacement of the existing 6” AC and CI water line on 3<sup>rd</sup> Avenue North from June Street to Greta Street with new 8” water main to improve fire flows in the area (**20-year plan**).
26. **Mill Street Water System Improvements** – This improvement consists of the construction of an 8” water line on Mill Street and 9<sup>th</sup> Avenue to improvement fire flows in the area (**20-year plan**).

27. **Airport Booster Pump Station** – This improvement consists of the construction of a new booster pump station to address fire flow deficiencies near the airport **(20-year plan)**.
28. **2<sup>nd</sup> Avenue Water System Improvements** – This improvement consists of the installation of an 8” water main on 2<sup>nd</sup> Avenue from Oak Street to Greta Street **(20-year plan)**.
29. **North River Crossing** – This improvement consists of the installation of a 12” water main crossing the Okanogan River and eventual connection (at location to be determined location) to the Elmway Water Main Extension Phase 3 **(20-year plan)**.
30. **4<sup>th</sup> Avenue Water Main and Valve Replacement** – This improvement consists of the installation of an 8” water main on 4<sup>th</sup> Avenue from Pine Street to Lower Pine Street and the replacement of the valve cluster located at the intersection of 4<sup>th</sup> Avenue and Queen Street **(20-year plan)**.

## SCHEDULE

A schedule for the City’s planned capital improvements is provided in Table 8-1.

**TABLE 8-1**

### Capital Improvement Plan

PROJECT	OCT. 2015 COST <sup>(1)</sup>	YEAR PLANNED						
		'16	'17	'18	'19	'20	'21	>'21
<b>MISCELLANEOUS</b>								
Water Rights Consolidation	\$10,000	X						
Source Protective Covenants	-----	X						
Progressive Flats Agreement Review	-----	X						
<b>TELEMETRY</b>								
1. Telemetry System Improvements	\$60,000				X			
<b>SOURCE</b>								
2. Watercress Springs Feasibility Study	\$15,000		X					
3. Well Improvements	\$246,000			X				
4. Well Decommissioning	\$222,000			X				
5. Well No. 3 Inspection	\$36,000			X				
6. Well No. 4 Bypass	\$28,000			X				
7. Well No. 6 (Riverwalk Well)								X
<b>TREATMENT</b>								
8. Arsenic Treatment Facility Feasibility	\$5,000	X						
9. Arsenic Treatment Facility Improve.	\$50,000		X					
10. Well Chlorination Improvements								X
<b>STORAGE</b>								
11. Murray Reservoir								X
12. West Reservoirs Improvements								X
13. East Reservoir Improvements								X
<b>DISTRIBUTION</b>								
14. Murray Street Master Meter	\$60,000	X						
15. Murray Street Booster Pump Station	\$467,000						X	
16. 5 <sup>th</sup> Avenue Water Main Replacement	\$466,000	X						
17. Elmway Water Main Ext. Phase 3	\$877,000		X					
18. 1 <sup>st</sup> Avenue Water Main	\$1,395,000						X	

**TABLE 8-1 con't**

**Capital Improvement Plan**

PROJECT	OCT. 2015 COST <sup>(1)</sup>	YEAR PLANNED						
		'16	'17	'18	'19	'20	'21	>'21
<b>DISTRIBUTION CON'T</b>								
19. South Okanogan Water System Improvements	\$1,097,000						X	
20. Rodeo Trail Water Main Replacement	\$729,000						X	
21. Highland Dr Water Main Replacement	\$224,000						X	
22. Tacoma/Spokane Streets Water Loop	\$623,000						X	
23. 2 <sup>nd</sup> Avenue S. Water Main Replacement								X
24. Viewmont Dr Water Main Replacement								X
25. 3 <sup>rd</sup> Avenue N. Water Main Replacement								X
26. Mill Street Water System Improvements								X
27. Airport Booster Pump Station								X
28. 3 <sup>rd</sup> Avenue Water System Improvements								X
29. North River Crossing								X
30. 4 <sup>th</sup> Avenue Water Main Replacement								X

<sup>(1)</sup> 6-year capital improvement only; construction costs for 20-year capital improvements not included.

CAPITAL IMPROVEMENTS			
NO.	DESCRIPTION	NO.	DESCRIPTION
1	TELEMETRY SYSTEM IMPROVEMENTS	16	5TH AVENUE WATER MAIN REPLACEMENT
2	WATERCRESS SPRINGS FEASIBILITY STUDY	17	ELMWAY WATER MAIN EXTENSION (PHASE 3)
3	WELL IMPROVEMENTS	18	1ST AVENUE WATER MAIN
4	WELL DECOMMISSIONING	19	SOUTH OKANOGAN WATER SYSTEM IMPROVEMENTS
5	WELL NO. 3 INSPECTION	20	RODEO TRAIL WATER MAIN REPLACEMENT
6	WELL NO. 4 BYPASS	21	HIGHLAND DRIVE WATER MAIN REPLACEMENT
7*	WELL NO. 6 (RIVERWALK WELL)	22	TACOMA STREET/SPOKANE STREET WATER MAIN LOOP
8	ARSENIC TREATMENT FACILITY FEASIBILITY STUDY	23*	2ND AVENUE SOUTH WATER MAIN REPLACEMENT
9	ARSENIC TREATMENT FACILITY IMPROVEMENTS	24*	VIEWMONT DRIVE WATER MAIN REPLACEMENT
10*	WELL CHLORINATION IMPROVEMENTS	25*	3RD AVENUE NORTH WATER MAIN REPLACEMENT
11*	MURRAY RESERVOIR	26*	MILL STREET WATER SYSTEM IMPROVEMENTS
12*	WEST RESERVOIRS IMPROVEMENTS	27*	AIRPORT BOOSTER PUMP STATION
13*	EAST RESERVOIRS IMPROVEMENTS	28*	2ND AVENUE WATER SYSTEM IMPROVEMENTS
14	MURRAY STREET MASTER METER	29*	NORTH RIVER CROSSING
15	MURRAY STREET BOOSTER PUMP STATION	30*	4TH AVENUE WATER MAIN AND VALVE REPLACEMENT

\* 20-YEAR IMPROVEMENT SCHEDULE      NOTE: ITEMS NOT SHOWN IN PRIORITIZED ORDER

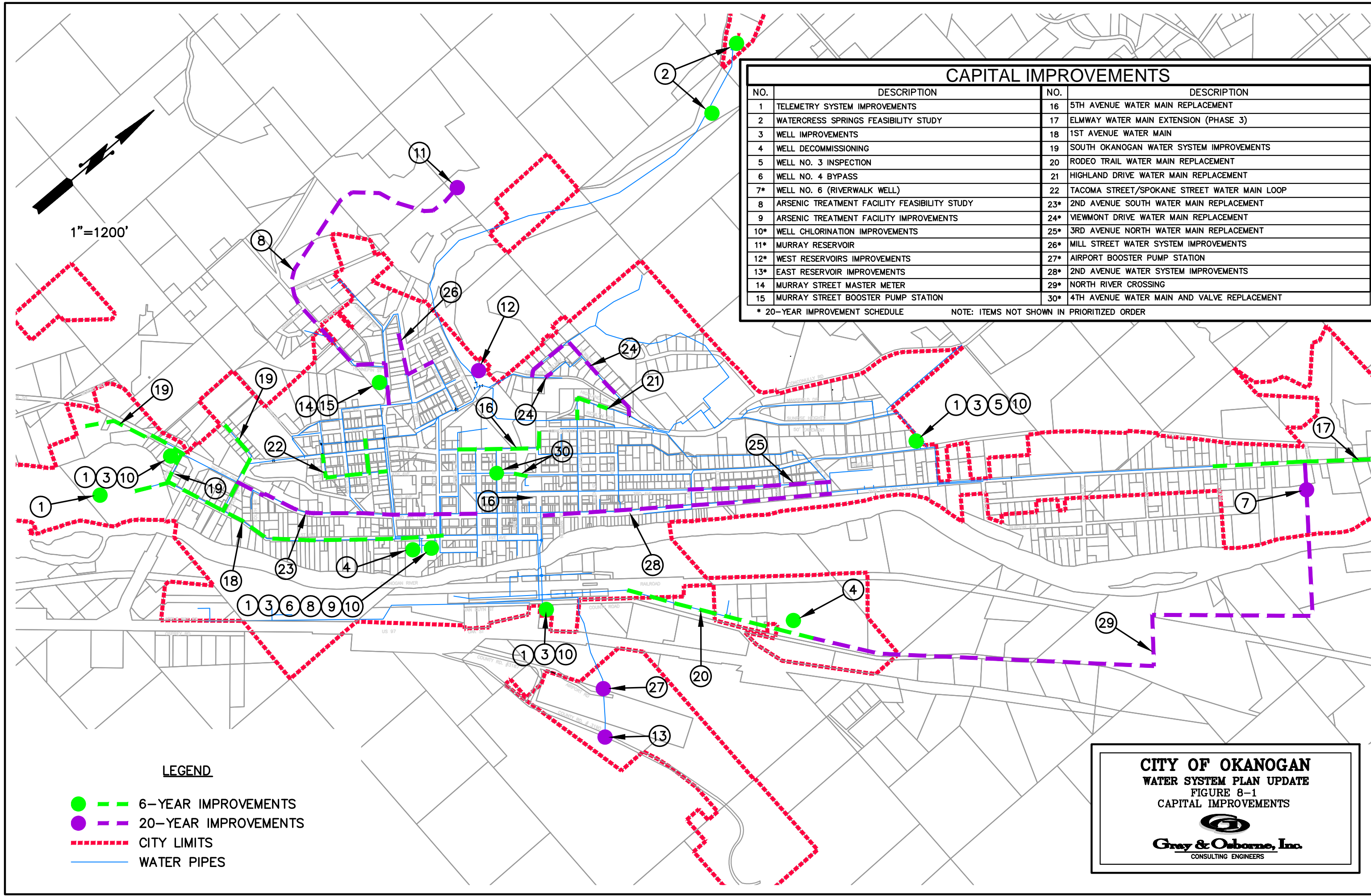

- LEGEND**
- 6-YEAR IMPROVEMENTS
  - 20-YEAR IMPROVEMENTS
  - CITY LIMITS
  - WATER PIPES

**CITY OF OKANOGAN**  
**WATER SYSTEM PLAN UPDATE**  
 FIGURE 8-1  
 CAPITAL IMPROVEMENTS

**Gray & Osborne, Inc.**  
 CONSULTING ENGINEERS



## CHAPTER 9

### CAPITAL IMPROVEMENT FINANCING

#### EXISTING RATES AND CHARGES

Water service rates were established by Ordinance No. 1146 Appendix “A”, City of Okanogan Fee Schedule. Manual-read meters are read monthly April through September, while radio-read meters are read every month. Customers are billed on a monthly basis according to the rate schedule shown in Table 9-1. Each customer with a 5/8–inch meter, the size typically installed by the City, is charged a minimum monthly charge of \$36.76 (2016 rate), which includes the first 5,000 gallons of metered water consumption. Accounts outside the City limits are charged \$80.00 for the same volume. The rates will be in effect starting January 1, 2016.

**TABLE 9-1**

#### 2016 Water Service Rates for First 5,000 gallons per Month

Customer Class	Base Rate for First 5,000 gallons
Residential – in City Limits	\$36.76
Commercial – in City Limits	\$36.76
Residential - Outside City Limits	\$80.00
Commercial – Outside City Limits	\$80.00

For usage beyond 5,000 gallons per month, the customer incurs volume charges as indicated in Table 9-2.

**TABLE 9-2**

#### 2016 Water Service Volume Charges

Customer Class	Volume Charge
Residential – in City Limits: each additional 1,000 gals	\$1.61 per 1,000 gal
Commercial – in City Limits: each additional 1,000 gals	\$1.61 per 1,000 gal
Residential – Outside City Limits: each additional 1,000 gals	\$2.05 per 1,000 gal
Commercial – Outside City Limits: each additional 1,000 gals	\$2.05 per 1,000 gal

Connection charges are also covered under Ordinance No. 1156 Appendix “A”, and are summarized in Table 9-3. These are charges for City installation of new service lines and physically connecting to the system. In addition to these charges, the City charges new customers a “General Facilities Charge” per unit.

**TABLE 9-3**

**2016 Connection Charges**

<b>Installation of New Service Lines</b>	<b>Charges</b>
¾-inch Water Service	\$2,100
1-inch Water Service	\$2,350
2-inch Water Service	\$2,600
General Facilities Charge (per unit)	\$3,000
<b>Connection to Developer Provided Connection(1)</b>	
¾-inch Water Service	\$560
General Facilities Charge (per unit)	\$3,000

(1) This rate applicable only to new subdivisions where the developer provides the water system connection to a meter box at each individual lot.

The City is in the process of performing a study of the City’s water rates and connection charges in order to re-evaluate appropriate charges for the water system users. It is likely that this study will be completed in early 2016.

**MONTHLY CHARGES PER CUSTOMER CLASS**

Table 9-4 presents the average monthly bill per customer class for the years 2010 to 2014 based on the actual amount of water consumed per customer class. The average single family residential customer monthly bill in 2014 was \$41.55 which had increased from \$34.92 in 2010. This increase was mainly due to the fact that the City has raised rates every year since 2012.

**TABLE 9-4**

**Average Monthly Bill per Customer Class**

<b>Customer Class</b>	<b>2010</b>	<b>2011</b>	<b>2012</b>	<b>2013</b>	<b>2014</b>
Commercial	\$54.59	\$56.19	\$52.70	\$61.81	\$64.77
Multi Family	\$136.38	\$143.47	\$146.94	\$156.92	\$176.57
Rural	\$79.94	\$82.42	\$82.16	\$95.70	\$94.22
Schools	\$193.43	\$171.90	\$214.79	\$293.84	\$279.37
Single Family	\$34.92	\$35.00	\$33.79	\$39.23	\$41.55
All	\$46.95	\$47.31	\$46.15	\$53.92	\$57.05

**PAST AND PRESENT FINANCIAL STATUS**

The City has a combined water sewer fund. The City fund has separate line items for water and sewer revenues and expenses. Table 9-5 presents a summary of the City’s

water revenues and expenditures for the years 2010 to 2014. There are several items worth noting in the table.

- The table assumes that half of the interest revenue is allocated to the water fund.
- The table assumes that half of the transfer to the PW Equipment Reserves is allocated to the water fund.
- The table allocates ten percent of the 2014 beginning of Water/Sewer fund balance to the Water Fund because the water fund expenses have been exceeding its revenues. Most of the Water/Sewer Fund balance has been accrued by the sewer system.
- Revenue from water sales increased from 2012 to 2014 because the City increased water rates each year.
- The debt service for the 12-inch water main was paid off in 2013.
- The local debt for the Highlands water project and the transfers to the bond redemption was paid off in 2014.
- The telemetry loan last payment (\$7,800 annual payment) will be 2021 and the Highlands Loan 20-Year last payment (\$63,500 annual payment) will be 2022.
- The City has a separate water/sewer reserve fund that had a 2014 end of fund balance of \$478,996. This can be allocated to either the water or sewer system.
- The City has a separate water/sewer renewal and replacement fund that had a 2014 end of fund balance of \$70,818. This can be allocated to either the water or sewer system.
- Expenses have exceeded revenues for the Water portion of the water/sewer fund every year from 2010 to 2014. In the last two years, three loans have been paid off with \$32,000 in debt payments. Therefore in 2015, revenues will exceed expenses. The water fund balance was \$45,685 at the end of year for 2014.

**TABLE 9-5**

**Water Utility Historical Revenue and Expenditures  
(Summarized from the City's Revenue and Expenditure Reports)**

<b>REVENUES</b>	<b>2010</b>	<b>2011</b>	<b>2012</b>	<b>2013</b>	<b>2014</b>
Water Sales	\$519,554	\$519,268	\$534,183	\$606,427	\$636,955
Water Sales Penalty	\$4,767	\$4,237	\$4,908	\$3,228	\$3,276
Interest	\$1,100	\$626	\$650	\$555	\$316
Miscellaneous	\$2,894	\$2,900	\$1,958	\$2,409	\$3,164
<b>Total Revenue</b>	<b>\$528,315</b>	<b>\$527,031</b>	<b>\$541,699</b>	<b>\$612,620</b>	<b>\$643,712</b>
<b>EXPENDITURES</b>	<b>2010</b>	<b>2011</b>	<b>2012</b>	<b>2013</b>	<b>2014</b>
Salaries and Benefits	\$248,858	\$253,484	\$245,283	\$267,490	\$268,889
Supplies	\$37,843	\$39,338	\$29,450	\$38,870	\$40,118
Professional Services, Communications and Training	\$29,028	\$31,541	\$35,676	\$36,013	\$34,224
Public Utility Services	\$36,227	\$37,703	\$43,870	\$46,545	\$46,938
Repairs Maintenance	\$13,621	\$19,038	\$11,272	\$7,378	\$22,625
Miscellaneous	\$2,863	\$4,367	\$1,813	\$2,256	\$2,291
Utility and Excise tax	\$82,959	\$79,996	\$72,144	\$95,422	\$88,185
<b>Total Water Expenditures</b>	<b>\$451,398</b>	<b>\$465,466</b>	<b>\$439,508</b>	<b>\$493,973</b>	<b>\$503,270</b>
Debt Service 12' Water Main	\$14,000	\$471	\$2,017	\$477	\$0
PWTF Telemetry Loan	\$7,957	\$7,919	\$7,882	\$7,844	\$7,806
PWTB Highlands 20 Year	\$64,961	\$64,656	\$64,351	\$64,046	\$63,741
Local Debt Highlands 10 Year.	\$28,466	\$28,466	\$28,466	\$27,767	\$14,233
<b>Total Debt Payments</b>	<b>\$115,384</b>	<b>\$101,512</b>	<b>\$102,716</b>	<b>\$100,134</b>	<b>\$85,781</b>
Capital Projects & Machinery	\$19,348	\$28,452	\$30,287	\$34,707	\$34,860
Transfers Out to Bond Redemption	\$32,390	\$31,115	\$34,815	\$33,225	\$31,620
Transfers out to PW Equip Reserves	\$11,000	\$11,000	\$11,000	\$11,000	\$11,000
<b>Total Expenditures</b>	<b>\$629,519</b>	<b>\$637,545</b>	<b>\$618,326</b>	<b>\$673,039</b>	<b>\$666,530</b>
<b>ACCUMULATED REVENUES</b>	<b>2010</b>	<b>2011</b>	<b>2012</b>	<b>2013</b>	<b>2014</b>
Beginning Balances	417,270	316,065	205,551	128,923	68,504
Revenues - Expenditures	-\$101,204	-\$110,514	-\$76,628	-\$60,420	-\$22,818
<b>Year-End Total</b>	<b>\$316,065</b>	<b>\$205,551</b>	<b>\$128,923</b>	<b>\$68,504</b>	<b>\$45,685</b>

## FUNDING SOURCES

The following is a discussion of the most likely funding sources for the water capital improvement projects.

- City Funded - The water system has approximately \$500,000 in available funding (fund balances for water fund, water/sewer reserve fund and water/sewer replacement fund) and rates that can be used to fund small capital projects. Typically large projects greater than \$100,000 are not City funded because the City does not typically have sufficient available fund balance to fund larger projects.
- Public Works Trust Fund - The state has not funded this program for several years and the future of this funding source is unknown. This plan will assume that this funding source is not available.
- Community Development Block Grant - The City is not eligible for this program because the City's median household income is too high.
- Drinking Water State Revolving Fund (DWSRF) - DWSRF will provide loan funding for water system projects. Health and safety projects will receive the highest rankings and receive funding. Water main projects, even those projects that improve fire flow typically do not receive a ranking high enough to receive funding.
- Rural Development - Rural Development will provide grant and loan financing for most of the projects that are on the six-year capital improvement plan. Rural Development will provide loans from 20 to 40 years in duration. It is best to use Rural Development for large capital projects or combine several capital projects into a large project because of the requirements of Rural Development.
- Revenue Bonds - Can be utilized to fund any water system improvement. However the interest rates for revenue bonds are typically higher than other funding options.

Table 9-6 presents possible funding sources for the capital improvements listed in the six year capital improvement plan. It is unlikely that the City will receive grant funding until the monthly water bill is at least 2.5% of the median household income. With a median household income of \$45,020 grant funding will most likely not be provided until the monthly water bills are around \$90 per month.

**TABLE 9-6**  
**Possible Funding Sources**

<b>ITEM</b>	<b>COST</b>	<b>FUNDING SOURCE <sup>(1)</sup></b>			
Water Rights Consolidation	\$10,000	City			
<b>TELEMETRY</b>					
Telemetry System Improvements	\$60,000	City		RD	Rev. Bond
<b>SOURCE</b>					
Watercress Springs Feasibility Study	\$15,000	City			
Well Improvements	\$246,000		DWSRF	RD	Rev. Bond
Well Decommissioning	\$222,000		DWSRF	RD	Rev. Bond
Well No. 3 Inspection	\$36,000	City		RD	Rev. Bond
Well No. 4 Bypass	\$28,000	City		RD	Rev. Bond
<b>TREATMENT</b>					
Arsenic Treatment Facility Feasibility	\$5,000	City			
Arsenic Treatment Facility Improvement	\$50,000	City	DWSRF	RD	Rev. Bond
<b>DISTRIBUTION</b>					
Murray Street Master Meter	\$60,000	City		RD	Rev. Bond
Murray Street Booster Pump Station	\$467,000			RD	Rev. Bond
5 <sup>th</sup> Avenue Water Main Replacement	\$466,000			RD	Rev. Bond
Elmway Water Main Ext. Phase 3	\$877,000			RD	Rev. Bond
1 <sup>st</sup> Avenue Water Main Improvements	\$1,395,000			RD	Rev. Bond
South Okanogan Water System Improvements	\$1,097,000			RD	Rev. Bond
Rodeo Trail Water Main Replacement	\$729,000			RD	Rev. Bond
Highland Dr Water Main Replacement	\$224,000			RD	Rev. Bond
Tacoma/Spokane Streets Water Loop	\$623,000			RD	Rev. Bond

(1) DWSRF - Drinking Water State Revolving Fund, RD - Rural Development, Rev. Bond - Revenue Bond.

## SIX-YEAR FINANCING PLAN

The six year financing plan assumes the following:

- That inflation is 3 percent per year.
- That the following projects will be funded with City funds; water rights consolidation, Water Crest Springs Feasibility Study, Well No. 3 Inspection, Arsenic Treatment Facility Feasibility Study, Arsenic Treatment Facility Improvement, Telemetry System Improvement and Murray Street Master Meter.



- That the financing plan will increase the end of year fund balance from \$45,000 to approximately \$110,000 in 2021. This is sufficient because the City has a Water/Sewer Reserve account with a balance of \$479,000

The following alternatives were analyzed for funding the remaining capital improvement projects.

- Alternative 1 includes no capital improvement projects and determines the effects of inflation on the rates.
- Alternative 2 includes a 20-year RD loan for replacement of the 5th Avenue Water Main (2016) project.
- Alternative 3 includes all City funded capital improvement projects and a 20-year RD loan for replacement of the 5th Avenue Water Main (2016) project.
- Alternative 4 includes all City funded capital improvement projects; 20-year RD loans for replacement of the 5th Avenue Water Main (2016) and Elmway Water Main Extension Phase 3 (2017) projects; 20-Year DWSRF loan to fund the well improvements (2018); and 20-Year RD loan for all other water distribution projects (2021).
- Alternative 5 includes all City funded capital improvement projects; 20-year RD loans for replacement of the 5th Avenue Water Main (2016) and for all other projects (2018).
- Alternative 6 includes all City funded capital improvement projects; 20-year RD loan for replacement of the 5th Avenue Water Main (2016); and a 40-year RD loan for all other projects (2018).

Table 9-7 summarizes the rate impacts of the funding alternatives.

**TABLE 9-7**

**Rate Impacts Funding Alternatives**

	<b>Annual Rate Increase 2017 to 2021</b>	<b>2014 SFR Avg. Monthly Bill <sup>(1)</sup></b>	<b>2021 SFR Avg. Monthly Bill <sup>(1)</sup></b>	<b>Total Rate Increase</b>
Alternative 1	2.3%	\$41.55	\$48.40	16.5%
Alternative 2	4.1%	\$41.55	\$52.43	26.2%
Alternative 3	7.1%	\$41.55	\$59.81	44.0%
Alternative 4	12.3%	\$41.55	\$74.77	80.0%
Alternative 5	19.3%	\$41.55	\$99.90	140.5%
Alternative 6	11.6%	\$41.55	\$72.58	74.7%

(1) SFR - Single Family Residential.

This analysis determined the following:

- A 2.3% annual rate increase from 2017 to 2021 is required to fund the existing water system with inflation.
- A 4.1% annual rate increase from 2017 to 2021 is required to fund the existing water system with inflation and to fund the planned capital improvement project of replacing the water mains on 5th Avenue.
- An approximately water rate increase of 11.6% per year from 2017 to 2021 is required to fund all of the capital projects under Alternative No. 4 or 6.

The water and sewer committee determined that either Alternative No. 4 or No. 6 was the most likely method to fund the capital improvement projects.

Table 9-8 provides a comparison of the existing average monthly bill for a residential users verse the average monthly bill for other Cities in eastern Washington.

**TABLE 9-8**  
**Monthly Bill Comparison**  
**Versus Other Eastern Washington Cities <sup>(1)</sup>**

<b>City</b>	<b>Base Rate</b>	<b>Volume Included in Base Rate (gals)</b>	<b>Overage Rate (\$/gallon)</b>	<b>Monthly Bill (\$)</b>
Wapato	\$24.68	2,244	\$0.00801	76.41
Entiat	\$44.59	0	\$0.00100	53.29
Mabton	\$39.85	4,010	\$0.00128	45.85
Ephrata	\$39.00	0	\$0.00064	44.57
Okanogan	\$35.35	5,000	\$0.00155	41.55
Cle Elum	\$41.23	8,977	\$0.00147	40.82
Toppenish	\$29.97	4,488	\$0.00171	37.17
Grandview	\$24.61	3,000	\$0.00217	36.98
Chelan	\$35.06	6,900	\$0.00104	36.93
Zillah	\$12.20	2,244	\$0.00373	36.27
Ellensburg	\$21.46	0	\$0.00163	35.64
Sunnyside	\$16.88	2,244	\$0.00231	31.81
Prosser	\$18.95	2,992	\$0.00221	31.54
Wenatchee	\$10.68	0	\$0.00231	30.78
Omak	\$29.05	7,480	\$0.00086	30.09
Spokane	\$26.00	4,488	\$0.00080	29.38
Moses Lake	\$22.60	3,740	\$0.00112	28.17
Yakima	\$8.77	0	\$0.00195	25.73
Quincy	\$14.43	2,992	\$0.00059	17.79

(1) Based on 286 gallons of water use per day.

Table 9-9 presents the capital improvement program for Alternative No. 6.

**TABLE 9-9**

**Six Year Financing Plan**

<b>REVENUES</b>	<b>2016</b>	<b>2017</b>	<b>2018</b>	<b>2019</b>	<b>2020</b>	<b>2021</b>
Water Sales (2016 rates)	\$640,000	\$640,000	\$640,000	\$640,000	\$640,000	\$640,000
Water Sales due to Increase in Water Rates	\$0	\$74,000	\$154,000	\$241,000	\$334,000	\$435,000
Water Sales Penalty	\$4,000	\$4,000	\$4,000	\$4,000	\$4,000	\$4,000
Interest	\$0	\$0	\$0	\$0	\$0	\$0
Miscellaneous	\$2,000	\$2,500	\$2,500	\$2,500	\$2,500	\$2,500
Grants and Loans	\$480,000	\$0	\$6,457,000	\$0	\$0	\$0
<b>Total Revenue</b>	<b>\$1,126,000</b>	<b>\$720,500</b>	<b>\$7,257,500</b>	<b>\$887,500</b>	<b>\$980,500</b>	<b>\$1,081,500</b>
<b>EXPENDITURES</b>	<b>2016</b>	<b>2017</b>	<b>2018</b>	<b>2019</b>	<b>2020</b>	<b>2021</b>
Salaries and Benefits	\$286,000	\$295,000	\$304,000	\$313,000	\$322,000	\$332,000
Supplies	\$32,000	\$33,000	\$34,000	\$35,000	\$36,000	\$37,000
Professional Services, Communications and Training	\$36,000	\$37,000	\$38,000	\$39,000	\$40,000	\$41,000
Public Utility Services	\$50,000	\$52,000	\$54,000	\$56,000	\$58,000	\$60,000
Repairs Maintenance	\$17,000	\$18,000	\$19,000	\$20,000	\$21,000	\$22,000
Miscellaneous	\$5,000	\$5,000	\$5,000	\$5,000	\$5,000	\$5,000
Utility and Excise tax	\$89,000	\$99,000	\$110,000	\$122,000	\$135,000	\$149,000
<b>Total Water Department Expenditures</b>	<b>\$515,000</b>	<b>\$539,000</b>	<b>\$564,000</b>	<b>\$590,000</b>	<b>\$617,000</b>	<b>\$646,000</b>
Existing Debt Payments	\$70,500	\$70,000	\$69,500	\$69,000	\$68,500	\$68,000
New Debt Payments	\$0	\$29,000	\$29,000	\$29,000	\$265,000	\$265,000
Capital Projects & Machinery	\$35,000	\$36,000	\$37,000	\$38,000	\$39,000	\$40,000
City Funded Capital Projects	\$10,000	\$20,000	\$95,000	\$68,000	\$70,000	\$0
New Capital Projects	\$480,000	\$0	\$6,457,000	\$0	\$0	\$0
Transfers out to PW Equip Reserves	\$11,000	\$11,000	\$11,000	\$11,000	\$11,000	\$11,000
<b>Total Expenditures</b>	<b>\$1,121,500</b>	<b>\$705,000</b>	<b>\$7,262,500</b>	<b>\$805,000</b>	<b>\$1,070,500</b>	<b>\$1,030,000</b>
<b>ACCUMULATED REVENUES</b>	<b>2016</b>	<b>2017</b>	<b>2018</b>	<b>2019</b>	<b>2020</b>	<b>2021</b>
Beginning Balances	\$45,000	\$49,500	\$65,000	\$60,000	\$142,500	\$52,500
Revenues - Expenditures	\$4,500	\$15,500	-\$5,000	\$82,500	-\$90,000	\$51,500
<b>Year-End Total</b>	<b>\$49,500</b>	<b>\$65,000</b>	<b>\$60,000</b>	<b>\$142,500</b>	<b>\$52,500</b>	<b>\$104,000</b>

**APPENDIX A**

**WATER FACILITIES INVENTORY**



# WATER FACILITIES INVENTORY (WFI) FORM

ONE FORM PER SYSTEM

Quarter: 1  
Updated: 10/06/2014  
Printed: 5/14/2015

WFI Printed For: On-Demand  
Submission Reason: Pop/Connect

RETURN TO: Eastern Regional Office, 16201 E Indiana, Suite 1500, Spokane Valley, WA, 99216

1. SYSTEM ID NO.	2. SYSTEM NAME	3. COUNTY	4. GROUP	5. TYPE
63200 M	OKANOGAN WATER DEPARTMENT, CITY	OKANOGAN	A	Comm

6. PRIMARY CONTACT NAME & MAILING ADDRESS	7. OWNER NAME & MAILING ADDRESS	8. Owner Number 004214
LOREN L. HOWELL PO BOX 752 OKANOGAN, WA 98840	OKANOGAN, CITY OF LOREN L. HOWELL PO BOX 752 OKANOGAN, WA 98840	TITLE: WATER MANAGER
<b>STREET ADDRESS IF DIFFERENT FROM ABOVE</b>	<b>STREET ADDRESS IF DIFFERENT FROM</b>	
ATTN ADDRESS CITY STATE ZIP	ATTN ADDRESS 1601 1ST AVE S CITY OKANOGAN STATE WA ZIP 98840	

9. 24 HOUR PRIMARY CONTACT INFORMATION	10. OWNER CONTACT INFORMATION
Primary Contact Daytime Phone: (509) 422-0717	Owner Daytime Phone: (509) 422-3902
Primary Contact Mobile/Cell Phone:	Owner Mobile/Cell Phone: (509) 322-0150
Primary Contact Evening Phone: (xxx) xxx-xxxx	Owner Evening Phone: (xxx) xxx-xxxx
Fax:   E-mail: XXXXXX	Owner Fax Phone:   E-mail: XXXXXX

**WAC 246-290-420(9) requires that water systems provide 24-hour contact information for emergencies.**

11. SATELLITE MANAGEMENT AGENCY - SMA (check only one)
<input checked="" type="checkbox"/> Not applicable (Skip to #12) <input type="checkbox"/> Owned and Managed SMA NAME: _____ SMA Number: _____ <input type="checkbox"/> Managed Only <input type="checkbox"/> Owned Only

12. WATER SYSTEM CHARACTERISTICS (mark all that apply)
<input type="checkbox"/> Agricultural <input checked="" type="checkbox"/> Commercial / Business <input checked="" type="checkbox"/> Day Care <input checked="" type="checkbox"/> Food Service/Food Permit <input type="checkbox"/> 1,000 or more person event for 2 or more days per year <input checked="" type="checkbox"/> Hospital/Clinic <input type="checkbox"/> Industrial <input checked="" type="checkbox"/> Licensed Residential Facility <input checked="" type="checkbox"/> Lodging <input type="checkbox"/> Recreational / RV Park <input checked="" type="checkbox"/> Residential <input checked="" type="checkbox"/> School <input type="checkbox"/> Temporary Farm Worker <input checked="" type="checkbox"/> Other (church, fire station, etc.): _____

13. WATER SYSTEM OWNERSHIP (mark only one)	14. STORAGE CAPACITY (gallons)
<input type="checkbox"/> Association <input checked="" type="checkbox"/> City / Town <input type="checkbox"/> County <input type="checkbox"/> Federal <input type="checkbox"/> Investor <input type="checkbox"/> Private <input type="checkbox"/> Special District <input type="checkbox"/> State	1,710,000

- SEE NEXT PAGE FOR A COMPLETE LIST OF SOURCES -



# WATER FACILITIES INVENTORY (WFI) FORM - Continued

1. SYSTEM ID NO.	2. SYSTEM NAME					3. COUNTY					4. GROUP		5. TYPE																
63200 M	OKANOGAN WATER DEPARTMENT, CITY					OKANOGAN					A		Comm																
15	16 SOURCE NAME	17 INTERTIE	18 SOURCE CATEGORY							19 USE	20 TREATMENT					22 DEPTH	23	24 SOURCE LOCATION											
			Source Number	LIST UTILITY'S NAME FOR SOURCE AND WELL TAG ID NUMBER.  Example: WELL #1 XYZ456  IF SOURCE IS PURCHASED OR INTERTIED, LIST SELLER'S NAME Example: SFATTI F	INTERTIE SYSTEM ID NUMBER	WELL	WELL FIELD	WELL IN A WELL	SPRING		SPRING IN OPEN FIELD	SEA WATER	SURFACE WATER	RANNEY / INF.	OTHER			PERMANENT	SEASONAL	EMERGENCY	SOURCE METERED	NONE	CHLORINATION	FILTRATION	FLUORIDATION	IRRADIATION (UV)	OTHER	DEPTH TO FIRST OPEN INTERVAL IN FEET	CAPACITY (GALLONS PER MINUTE)
S01	InAct 09/13/1995 Alma Park		X													X	Y	X						90	100	SE NE	17	33N	26E
S02	Well #2 - ABR535		X										X			Y	X							95	200	SE NW	16	33N	26E
S03	Well #3 - AGJ158		X										X			Y	X							117	650	SW NE	09	33N	26E
S04	Well #4 - AGJ157		X										X			Y			X			X		285	550	SE NE	17	33N	26E
S05	InAct 01/01/1970 Salmon Creek					X							X					X						300		NE SW	05	33N	26E
S06	Well #5 - AGJ156		X										X			Y	X							94	350	SE SW	17	33N	26E

# WATER FACILITIES INVENTORY (WFI) FORM - Continued

<b>1. SYSTEM ID</b> 63200 M	<b>2. SYSTEM NAME</b> OKANOGAN WATER DEPARTMENT, CITY	<b>3. COUNTY</b> OKANOGAN	<b>4. GROUP</b> A	<b>5. TYPE</b> Comm
--------------------------------	--	------------------------------	----------------------	------------------------

	ACTIVE SERVICE CONNECTIONS	DOH USE ONLY! CALCULATED ACTIVE CONNECTIONS	DOH USE ONLY! APPROVED CONNECTIONS
<b>25. SINGLE FAMILY RESIDENCES (How many of the following do you have?)</b>	0	924	1400
A. Full Time Single Family Residences (Occupied 180 days or more per year)	723		
B. Part Time Single Family Residences (Occupied less than 180 days per year)	0		
<b>26. MULTI-FAMILY RESIDENTIAL BUILDINGS (How many of the following do you have?)</b>			
A. Apartment Buildings, condos, duplexes, barracks, dorms	44		
B. Full Time Residential Units in the Apartments, Condos, Duplexes, Dorms that are occupied more than 180 days/year	149		
C. Part Time Residential Units in the Apartments, Condos, Duplexes, Dorms that are occupied less than 180 days/year	52		
<b>27. NON-RESIDENTIAL CONNECTIONS (How many of the following do you have?)</b>			
A. Recreational Services and/or Transient Accommodations (Campsites, RV sites, hotel/motel/overnight units)	0	0	0
B. Institutional, Commercial/Business, School, Day Care, Industrial Services, etc.	148	148	0
<b>28. TOTAL SERVICE CONNECTIONS</b>		<b>1072</b>	<b>1400</b>

<b>29. FULL-TIME RESIDENTIAL POPULATION</b>
A. How many residents are served by this system 180 or more days per _____ <span style="float: right; margin-right: 50px;">2539</span>

30. PART-TIME RESIDENTIAL POPULATION	JAN	FEB	MAR	APR	MAY	JUN	JUL	AUG	SEP	OCT	NOV	DEC
A. How many part-time residents are present each month?												
B. How many days per month are they present?												

31. TEMPORARY & TRANSIENT USERS	JAN	FEB	MAR	APR	MAY	JUN	JUL	AUG	SEP	OCT	NOV	DEC
A. How many total visitors, attendees, travelers, campers, patients or customers have access to the water system each month?												
B. How many days per month is water accessible to the public?												

32. REGULAR NON-RESIDENTIAL USERS	JAN	FEB	MAR	APR	MAY	JUN	JUL	AUG	SEP	OCT	NOV	DEC
A. If you have schools, daycares, or businesses connected to your water system, how many students daycare children and/or employees are present each month?												
B. How many days per month are they present?												

33. ROUTINE COLIFORM SCHEDULE	JAN	FEB	MAR	APR	MAY	JUN	JUL	AUG	SEP	OCT	NOV	DEC
	3	3	3	3	3	3	3	3	3	3	3	3

**35. Reason for Submitting WFI:**

Update - Change  
  Update - No Change  
  Inactivate  
  Re-Activate  
  Name Change  
  New System  
  Other \_\_\_\_\_

**36. I certify that the information stated on this WFI form is correct to the best of my knowledge.**

SIGNATURE: \_\_\_\_\_

DATE: \_\_\_\_\_

PRINT NAME: \_\_\_\_\_

TITLE: \_\_\_\_\_

<u>WS ID</u>	<u>WS Name</u>
63200	OKANOGAN WATER DEPARTMENT, CITY OF

**Total WFI Printed: 1**

Individual System View - OKANOGAN WATER DEPARTMENT, CITY OF - Water System Id - 63200M

Compliance Actions		Operating Permits		Operators		Reports		Water Use Efficiency	
General Information		Source Information		Samples		Exceedances		Water Quality Monitoring Schedule	
Group	A	Status	Active	Ownership Type	City/Town	Type	Community	Residential Population	2,539
Owner Name	OKANOGAN WATER DEPARTMENT, CITY OF	NonResidential Population	0	Jurisdiction	WA DOH ODW	Total Calculated Connections	1,072	System Effective Date	1/1/1970
Primary Contact	Loren Howell	Total Approved Connections	1400	System Inactive Date		Distribution Capacity (gallons)	1,710,000	SMA Name	
Primary Contact Phone	(509) 422-0717			SMA Number					
Water System Mailing Address	PO Box 752 Okanogan, WA 98840								

[Home Page](#) | [Find Water Systems](#) | [Find Water Quality](#) | [Downloads/Reports](#)

[DOH Home](#) | [Community and Environment](#) | [Drinking Water Home](#) | [Drinking Water Contacts](#)  
[Access Local Health](#) | [Privacy Notice](#) | [Disclaimer/Copyright Information](#)

*Links to external resources are provided as a public service and do not imply endorsement by the Washington State Department of Health*

Department of Health, Office of Drinking Water

Street Address:  
 243 Israel Road S.E. 2nd floor  
 Tumwater, WA 98501

Mail:  
 PO BOX 47822  
 Olympia, WA 98504-7822

Phone: (360) 236-3100

Send inquiries about DOH and its programs to the [Health Consumer Assistance Office](#)  
 Comments or questions regarding this Web site? Send email to [Environmental Health Application Testing and Support](#) or call 360-236-4593.



Division of Environmental Health  
 Office of Drinking Water

Help

Individual System View - OKANOGAN WATER DEPARTMENT, CITY OF - Water System Id - 63200M

Compliance Actions		Operating Permits		Operators		Reports		Water Use Efficiency	
General Information		Source Information		Samples		Exceedances		Water Quality Monitoring Schedule	
<b>Source 01 - Alma Park</b>									
Source Status	Inactive	Usage	Emergency	WRIA	Okanogan	Intertie Supplying System	NA		
Type	Groundwater Well	Capacity (gpm)	100	Township	33	Intertie Supplying Number	NA		
Effective Date	1/1/1970	Treated	No	Range	26E				
Inactive Date	9/13/1995	Metered	Yes	Section	17				
DOE Well Tag Number		Well Depth (ft)	90	Qtr/Qtr Section	SENE				
<b>Source 03 - Well #3 - AGJ158</b>									
Source Status	Active	Usage	Seasonal	WRIA	Okanogan	Intertie Supplying System	NA		
Type	Groundwater Well	Capacity (gpm)	650	Township	33	Intertie Supplying Number	NA		
Effective Date	1/1/1970	Treated	No	Range	26E				
Inactive Date		Metered	Yes	Section	09				
DOE Well Tag Number	AGJ158	Well Depth (ft)	117	Qtr/Qtr Section	SWNE				
<b>Source 02 - Well #2 - ABR535</b>									
Source Status	Active	Usage	Permanent	WRIA	Okanogan	Intertie Supplying System	NA		
Type	Groundwater Well	Capacity (gpm)	200	Township	33	Intertie Supplying Number	NA		
Effective Date	1/1/1970	Treated	No	Range	26E				
Inactive Date		Metered	Yes	Section	16				
DOE Well Tag Number	ABR535	Well Depth (ft)	95	Qtr/Qtr Section	SENW				

Display as table with source treatment information



Division of Environmental Health  
 Office of Drinking Water

Help

Individual System View - OKANOGAN WATER DEPARTMENT, CITY OF - Water System Id - 63200M

Compliance Actions		Operating Permits		Operators		Reports		Water Use Efficiency	
General Information		Source Information		Samples		Exceedances		Water Quality Monitoring Schedule	
<b>Source 04 - Well #4 - AGJ157</b>									
Source Status	Active	Usage	Seasonal	WRIA	Okanogan	Intertie Supplying System	NA		
Type	Groundwater Well	Capacity (gpm)	550	Township	33	Intertie Supplying Number	NA		
Effective Date	1/1/1970	Treated	Yes	Range	26E				
Inactive Date		Metered	Yes	Section	17				
DOE Well Tag Number	AGJ157	Well Depth (ft)	285	Qtr/Qtr Section	SENE				
<b>Source 06 - Well #5 - AGJ156</b>									
Source Status	Active	Usage	Permanent	WRIA	Okanogan	Intertie Supplying System	NA		
Type	Groundwater Well	Capacity (gpm)	350	Township	33	Intertie Supplying Number	NA		
Effective Date	1/1/1970	Treated	No	Range	26E				
Inactive Date		Metered	Yes	Section	17				
DOE Well Tag Number	AGJ156	Well Depth (ft)	94	Qtr/Qtr Section	SESW				
<b>Source 05 - Salmon Creek Spring AGJ159 - (GWI)</b>									
Source Status	Inactive	Usage	Permanent	WRIA	Okanogan	Intertie Supplying System	NA		
Type	Groundwater Spring	Capacity (gpm)	300	Township	33	Intertie Supplying Number	NA		
Effective Date	1/1/1970	Treated	Yes	Range	26E				
Inactive Date	7/2/2003	Metered	Undefined	Section	05				
DOE Well Tag Number		Well Depth (ft)		Qtr/Qtr Section	NESW				

Display as table with source treatment information

## **APPENDIX B**

# **COMPREHENSIVE MONITORING PLAN**



**APPENDIX B-1**

**WATER QUALITY MONITORING REPORTS**



## Water Quality Monitoring Schedule

**System: OKANOGAN WATER DEPARTMENT, CITY OF**  
**Contact: Loren L Howell**

**PWS ID: 63200 M**  
**Group: A - Comm**

**Region: EASTERN**  
**County: OKANOGAN**

**NOTE: To receive credit for compliance samples, you must fill out laboratory and sample paperwork completely, send your samples to a laboratory accredited by Washington State to conduct the analyses, AND ensure the results are submitted to DOH Office of Drinking Water. There is often a lag time between when you collect your sample, when we credit your system with meeting the monitoring requirement, and when we generate the new monitoring requirement.**

### Coliform Monitoring Requirements

	Jul 2015	Aug 2015	Sep 2015	Oct 2015	Nov 2015	Dec 2015	Jan 2016	Feb 2016	Mar 2016	Apr 2016	May 2016	Jun 2016
<b>Coliform Monitoring Population</b>	2539	2539	2539	2539	2539	2539	2539	2539	2539	2539	2539	2539
<b>Number of Routine Samples Required</b>	3	3	3	3	3	3	3	3	3	3	3	3

- Collect samples from representative points throughout the distribution system.
- Collect required repeat samples following an unsatisfactory sample. In addition, collect a sample from each operating groundwater source.
- Collect no less than 5 routine samples in the month following one or more unsatisfactory samples, in accordance with your system's Coliform Monitoring Plan.
- For systems that chlorinate, record chlorine residual (measured when the coliform sample is collected) on the coliform lab slip.

### Chemical Monitoring Requirements

#### Distribution Monitoring

<u>Test Panel/Analyte</u>	<u># Samples Required</u>	<u>Compliance Period</u>	<u>Frequency</u>	<u>Last Sample Date</u>	<u>Next Sample Due</u>
Lead and Copper	10	Jan 2015 - Dec 2017	standard - 3 year	08/26/2014	Aug 2017
Asbestos	1	Jan 2011 - Dec 2019	standard - 9 year	06/10/2009	Jun 2018

Notes on Distribution System Chemical Monitoring

- For *Lead and Copper*:
- Collect samples from indoor faucets after the water has sat unused in the pipes for at least 6 hours, but no more than 12 hours.
  - Flush sample faucets with cold water the evening prior to collecting the sample.
  - If your sampling frequency is annual or once every 3 years, collect samples between June 1 and September 30.

For *Asbestos*: Collect the sample from one of your routine coliform sampling sites in an area of your distribution system that has asbestos concrete pipe.  
*Asbestos*:

### Source Monitoring

- Collect 'source' chemical monitoring samples from a tap after all treatment (if any), but before entering the distribution system.
- Washington State grants monitoring waivers for various test panels or analytes. Please note that we may require some monitoring as a condition of some waivers. We have granted complete waivers for dioxin, endothal, glyphosate, diquat, and insecticides.
- If "R&C" is listed in a monitoring requirement's frequency, the requirements are based on detections which are reliably and consistently below the health standard.

Source S02	Well #2 - ABR535	Well	Use - Permanent	Susceptibility - High	
<u>Test Panel/Analyte</u>	<u># Samples Required</u>	<u>Compliance Period</u>	<u>Frequency</u>	<u>Last Sample Date</u>	<u>Next Sample Due</u>
Nitrate	1	Jan 2015 - Dec 2015	standard - 1 year	08/04/2014	<b>Aug 2015</b>
Radionuclides	1	Oct 2015 - Dec 2015	increased - quarterly	05/12/2015	<b>Oct 2015</b>
Complete Inorganic (IOC)	1	Jan 2011 - Dec 2019	waiver - 9 year	06/14/2004	
Volatile Organics (VOC)	1	Jan 2015 - Dec 2015	R&C - 1 year	10/06/2014	<b>Oct 2015</b>
Herbicides	1	Jan 2014 - Dec 2016	standard - 3 year	07/30/2012	Oct 2016
Pesticides	1	Jan 2014 - Dec 2016	standard - 3 year	07/23/2004	Oct 2016
Soil Fumigants	0	Jan 2014 - Dec 2016	waiver - 3 year	06/08/2011	
Radium 226 + 228	1	Jan 2014 - Dec 2019	standard - 6 year	09/05/2007	<b>May 2015</b>
Uranium	1	Jan 2014 - Dec 2016	standard - 3 year	05/12/2015	
Gross Alpha	1	Jan 2014 - Dec 2019	standard - 6 year	08/21/2000	<b>May 2015</b>

Source S03	Well #3 - AGJ158	Well	Use - Seasonal	Susceptibility - High	
<u>Test Panel/Analyte</u>	<u># Samples Required</u>	<u>Compliance Period</u>	<u>Frequency</u>	<u>Last Sample Date</u>	<u>Next Sample Due</u>
Nitrate	1	Jan 2015 - Dec 2015	standard - 1 year	10/06/2014	<b>Jul 2015</b>
Complete Inorganic (IOC)	1	Jan 2011 - Dec 2019	waiver - 9 year	07/10/2008	Jul 2019
Arsenic	1	Jan 2014 - Dec 2016	standard - 3 year	07/10/2008	Jul 2016
Manganese	1	Jan 2014 - Dec 2016	standard - 3 year	07/10/2008	Jul 2016
Volatile Organics (VOC)	1	Jan 2014 - Dec 2019	waiver - 6 year	06/10/2009	Jul 2019
Herbicides	1	Jan 2014 - Dec 2022	waiver - 9 year	07/02/2012	Jul 2022

Source S03	Well #3 - AGJ158	Well	Use - Seasonal	Susceptibility - High	
<u>Test Panel/Analyte</u>	<u># Samples Required</u>	<u>Compliance Period</u>	<u>Frequency</u>	<u>Last Sample Date</u>	<u>Next Sample Due</u>
Pesticides	1	Jan 2014 - Dec 2022	waiver - 9 year	07/16/2007	Jul 2022
Soil Fumigants	0	Jan 2014 - Dec 2016	waiver - 3 year	08/21/2000	
Gross alpha	1	Jan 2014 - Dec 2019	standard - 6 year	10/06/2010	Oct 2016
Radium 228	1	Jan 2014 - Dec 2019	standard - 6 year	10/06/2010	Oct 2016

Source S04	Well #4 - AGJ157	Well	Use - Seasonal	Susceptibility - Low	
<u>Test Panel/Analyte</u>	<u># Samples Required</u>	<u>Compliance Period</u>	<u>Frequency</u>	<u>Last Sample Date</u>	<u>Next Sample Due</u>
Nitrate	1	Jan 2015 - Dec 2015	standard - 1 year	08/04/2014	<b>Jul 2015</b>
Complete Inorganic (IOC)	1	Jan 2011 - Dec 2019	waiver - 9 year	07/15/2013	
Arsenic	1	Jan 2015 - Mar 2015	increased - quarterly	06/09/2015	<b>Mar 2015</b>
Arsenic	1	Apr 2015 - Jun 2015	increased - quarterly	06/09/2015	
Arsenic	1	Jul 2015 - Sep 2015	increased - quarterly	06/09/2015	<b>Sep 2015</b>
Arsenic	1	Oct 2015 - Dec 2015	increased - quarterly	06/09/2015	<b>Oct 2015</b>
Manganese	1	Jan 2014 - Dec 2016	standard - 3 year	07/15/2013	Jul 2016
Volatile Organics (VOC)	1	Jan 2014 - Dec 2019	waiver - 6 year	06/10/2009	Jul 2019
Herbicides	1	Jan 2014 - Dec 2022	waiver - 9 year	06/10/2009	Jul 2022
Pesticides	1	Jan 2014 - Dec 2022	waiver - 9 year	06/10/2009	Jul 2022
Soil Fumigants	0	Jan 2014 - Dec 2016	waiver - 3 year	12/18/2001	
Gross alpha	1	Jan 2014 - Dec 2019	standard - 6 year	07/02/2012	Jul 2018
Radium 228	1	Jan 2014 - Dec 2019	standard - 6 year	10/16/2012	Jul 2018

Source S06	Well #5 - AGJ156	Well	Use - Permanent	Susceptibility - High	
<u>Test Panel/Analyte</u>	<u># Samples Required</u>	<u>Compliance Period</u>	<u>Frequency</u>	<u>Last Sample Date</u>	<u>Next Sample Due</u>
Nitrate	1	Jan 2015 - Dec 2015	standard - 1 year	10/06/2014	<b>Oct 2015</b>
Complete Inorganic (IOC)	1	Jan 2011 - Dec 2019	waiver - 9 year	10/06/2010	Oct 2019
Iron	1	Jan 2014 - Dec 2016	standard - 3 year	05/12/2015	
Manganese	1	Jan 2014 - Dec 2016	standard - 3 year	05/12/2015	
Volatile Organics (VOC)	1	Jan 2014 - Dec 2019	waiver - 6 year	04/07/2010	Apr 2016

<i>Source S06</i>	<i>Well #5 - AGJ156</i>	<i>Well</i>	<i>Use - Permanent</i>	<i>Susceptibility - High</i>	
<u>Test Panel/Analyte</u>	<u># Samples Required</u>	<u>Compliance Period</u>	<u>Frequency</u>	<u>Last Sample Date</u>	<u>Next Sample Due</u>
Herbicides	1	Jan 2014 - Dec 2022	waiver - 9 year	04/25/2012	Apr 2021
Pesticides	1	Jan 2014 - Dec 2022	waiver - 9 year	04/12/2007	Apr 2016
Soil Fumigants	0	Jan 2014 - Dec 2016	waiver - 3 year	11/05/2001	
Gross alpha	1	Jan 2014 - Dec 2016	standard - 3 year	03/02/2015	
Gross alpha	1	Jan 2014 - Dec 2019	standard - 6 year	03/02/2015	
Radium 228	1	Jan 2014 - Dec 2016	standard - 3 year	03/02/2015	
Radium 228	1	Jan 2014 - Dec 2019	standard - 6 year	03/02/2015	

Generated on: 07/30/2015

**Other Information**

<b>Other Reporting Schedules</b>	<b>Due Date</b>
Submit Consumer Confidence Report (CCR) to customers and ODW (Community systems only):	07/01/2015
Submit CCR certification form to ODW (Community systems only):	10/01/2015
Submit Water Use Efficiency report online to ODW (Community and other municipal water systems only):	07/01/2015
Send notices of lead and copper sample results to the customers sampled:	30 days after you receive the laboratory results
Submit Certification of customer notification of lead and copper results to ODW:	90 days after end of monitoring period

**Special Notes**

Collect MONTHLY arsenic samples for S04 after treatment.

**Eastern Regional Water Quality Monitoring Contacts**

- For questions regarding chemical monitoring: Stan Hoffman: (509) 329-2132: or Stan.Hoffman@doh.wa.gov
- For questions regarding DBPs: Russell Mau, p.e.: (509) 329-2116 or russell.mau@doh.wa.gov
- For questions regarding coliform bacteria and microbial issues: Mark Steward: (509) 329-2134 or Mark.Steward@doh.wa.gov

**Additional Notes**

The information on this monitoring schedule is valid as of the date in the upper left corner on the first page. However, the information may change with subsequent updates in our water quality monitoring database as we receive new data or revise monitoring schedules. There is often a lag time between when you collect your sample and when we credit your system with meeting the monitoring requirement.

We have not designed this monitoring schedule to display all compliance requirements. The purpose of this schedule is to assist water systems with planning for most water quality monitoring, and to allow systems to compare their records with DOH ODW records. Please be aware that this monitoring schedule does not include constituents that require a special monitoring frequency, such as monitoring affiliated with treatment.

Any inaccuracies on this schedule will not relieve the water system owner and operator of the requirement to comply with applicable regulations.

If you have any questions about your monitoring requirements, please contact the regional office staff listed above.

**APPENDIX B-2**

**COLIFORM MONITORING PLAN**



# Coliform Monitoring Plan

Coliform Monitoring Plan for: City of Okanogan

## A. System Information

Plan Date: May 2015

<b>Water System Name</b> City of Okanogan	<b>County</b> Okanogan	<b>System I.D. Number</b> 63200M
<b>Name of Plan Preparer</b> Shawn Davisson	<b>Position</b> City Public Works Director	<b>Daytime Phone #</b> (509) 422-3600
<b>Sources:</b> DOH Source Number, Source Name, Well Depth, Pumping Capacity	S02, Well #2, 95 ft, 200 gpm S03, Well #3, 117 ft, 650 gpm S04, Well #4, 285 ft, 550 gpm S06, Well #5, 94 ft, 350 gpm	
<b>Storage:</b> List and Describe	East Reservoir – 550,000 gallons North Reservoir – 550,000 gallons Highland Reservoir – 200,000 gallons West Reservoir #1 – 210,000 gallons West Reservoir #2 – 200,000 gallons	
<b>Treatment:</b> Source Number & Process	S02, No Treatment S03, No Treatment S04, Filtration Treatment S05, No Treatment	
<b>Pressure Zones:</b> Number and name	Zone 1, Zone 2, Zone 3, and Zone 4	
<b>Population by Pressure Zone</b>	Murray – 50 Highland – 150 Main – 2,395	
<b>Number of Routine Samples Required Monthly by Regulation:</b> 3	<b>Number of Sample Sites Needed to Represent the Distribution System:</b> 6	
<b>*Request DOH Approval of Triggered Source Monitoring Plan?</b>		Yes <input type="checkbox"/> No <input checked="" type="checkbox"/>

\*If approval is requested a fee will be charged for the review.

## B. Laboratory Information

<b>Laboratory Name</b> Edge Analytical	<b>Office Phone #</b> (800) 755-9295
<b>Address</b> 1620 South Walnut Street Burlington, WA 98232	<b>After Hours #</b>
<b>Hours of Operation</b> 8 AM to 5 PM, Monday through Friday	

<b>Contact Name</b>	
<b>Emergency Laboratory Name</b> Okanogan County Public Health	<b>Office Phone #</b> (509) 422-7140
<b>Address</b> 1234 South 2 <sup>nd</sup> Avenue Okanogan, WA 98840	<b>After Hours #</b>
<b>Hours of Operation</b> 7:30 AM to 4:30 PM, Monday through Friday	
<b>Contact Name</b>	

### C. Wholesaling of Groundwater

	Yes	No
<b>We are a consecutive system and purchase groundwater from another water system.</b>	<input type="checkbox"/>	<input checked="" type="checkbox"/>
If yes, Water System Name: _____  Contact Name: _____  Telephone Numbers: _____		
<b>We sell groundwater to other public water systems.</b>	<input checked="" type="checkbox"/>	<input type="checkbox"/>
If yes, Water System Name: <u>Progressive Flats Water District</u>  Contact Name: <u>Bob Blank</u> Telephone Numbers: <u>(509) 422-1968</u>		

**D. Routine, Repeat, and Triggered Source Sample Locations\***

Routine Sample Group 1:

Location/Address for <b><u>Routine</u> Sample Sites</b>	Location/Address for <b><u>Repeat</u> Sample Sites</b>
<b>X1.</b> 1617 N. 2 <sup>nd</sup> Ave. Breakroom Sink	1-1. 1409 Sunrise
	1-2. 847 N. 2 <sup>nd</sup> Ave.
	1-3. 1617 N. 2 <sup>nd</sup> Ave.
	1-4. 1331 N. 2 <sup>nd</sup> Ave.
	Source Contribution
<b>X2.</b> 1251 S. 2 <sup>nd</sup> Ave. Breakroom Sink	2-1. 146 lone Street
	2-2. 936 S. 1 <sup>st</sup> Ave.
	2-3. 1251 S. 2 <sup>nd</sup> Ave.
	2-4. 1161 S. 2 <sup>nd</sup> Ave.
	Source Contribution
<b>X3.</b> 1 Patrol Street Bathroom Sink	3-1. 115 Rose Street
	3-2. 146 lone Street
	3-3. 1 Patrol Street
	3-4. 847 N. 2 <sup>nd</sup> Ave.
	Source Contribution

Routine Sample Group 2:

Location/Address for <b>Routine Sample Sites</b>	Location/Address for <b>Repeat Sample Sites</b>
<b>X1.</b> 115 Rose Street Breakroom Sink	1-5. 146 lone St.
	1-6. 1 Patrol
	1-7. 115 Rose St.
	1-8. 1251 S. 2 <sup>nd</sup> Ave.
<b>X2.</b> 1409 Sunrise Test port - pump house	2-1. 142 Conconully Rd.
	2-2. 847 N. 2 <sup>nd</sup> Ave.
	2-3. 1409 Sunrise
	2-4. 1622 N. 2 <sup>nd</sup> Ave.
<b>X3.</b> 1331 N. 2 <sup>nd</sup> Ave. Breakroom Sink	3-1. 1617 N. 2 <sup>nd</sup> Ave.
	3-2. 847 N. 2 <sup>nd</sup> Ave.
	3-3. 1331 N. 2 <sup>nd</sup> Ave.
	3-4. 315 N. 2 <sup>nd</sup> Ave.

\*NOTE: If you need more than three routine samples to cover the distribution system, attach additional sheets as needed.

**\*\* When you collect the repeats, you must sample every source that was in use when the original routine sample was collected.**

**E. Reduced Triggered Source Monitoring Justification (add sheets as needed):**

System has multiple groundwater sources, not considering reducing the triggered source monitoring requirements. The "no" box has been checked in Section A.

**F. Routine Sample Rotation Schedule**

Month	Routine Site(s)	Month	Routine Site(s)
January	1	July	1
February	2	August	2
March	1	September	1
April	2	October	2
May	1	November	1
June	2	December	2

**G. Five Routine Sample Locations – Month after an Unsatisfactory Sample**

Routine Sample Group 1:

Location/Address for Routine Sample Site(s) Unsatisfactory the Previous Month	Location/Address for the five Routine Sample Sites
<b>X1.</b> <b>1617 N. 2<sup>nd</sup> Ave.</b>	1. 115 Rose St.
	2. 1409 Sunrise
	3. 1331 N. 2 <sup>nd</sup> Ave.
	4. 1622 N. 2 <sup>nd</sup> Ave.
	5. 1251 S. 2 <sup>nd</sup> Ave.
<b>X2.</b> <b>1251 S. 2<sup>nd</sup> Ave.</b>	1. 115 Rose St.
	2. 1409 Sunrise
	3. 1331 N. 2 <sup>nd</sup> Ave.
	4. 1661 S. 2 <sup>nd</sup> Ave.
	5. 1417 N. 2 <sup>nd</sup> Ave.
<b>X3.</b> <b>1 Patrol St.</b>	1. 115 Rose St.
	2. 1409 Sunrise
	3. 1331 N. 2 <sup>nd</sup> Ave.
	4. 1409 Sunrise
	5. 146 lone St.

Routine Sample Group 2:

Location/Address for <u>Routine</u> Sample Site(s) Unsatisfactory the Previous Month	Location/Address for the five <u>Routine</u> Sample Sites
<b>X1.</b>  <b>115 Rose St.</b>	<b>1. 1617 N. 2<sup>nd</sup> Ave.</b> <b>2. 1251 S 2<sup>nd</sup> Ave.</b> <b>3. 1 Patrol St.</b> <b>4. 847 N. 2<sup>nd</sup> Ave.</b> <b>5. 110 Oak St.</b>
<b>X2.</b>  <b>1409 Sunrise</b>	<b>1. 1617 N. 2<sup>nd</sup> Ave.</b> <b>2. 1251 S. 2<sup>nd</sup> Ave.</b> <b>3. 1 Patrol St.</b> <b>4. 1161 S. 2<sup>nd</sup> Ave.</b> <b>5. 146 lone St.</b>
<b>X3.</b>  <b>1331 N. 2<sup>nd</sup> Ave.</b>	<b>1. 1617 N. 2<sup>nd</sup> Ave.</b> <b>2. 1251 S. 2<sup>nd</sup> Ave.</b> <b>3. 1 Patrol St.</b> <b>4. 847 N. 2<sup>nd</sup> Ave.</b> <b>5. 315 N. 2<sup>nd</sup> Ave.</b>

## H. *E. coli*-present response plans

<b>Distribution System <i>E. coli</i> Response Plan</b>
<p><b>If we have <i>E. coli</i> in our distribution system we will immediately:</b></p> <ol style="list-style-type: none"><li>1. Call DOH (Mark Stewart – (253) 512-7072).</li><li>2. Collect repeat and triggered source samples per Part D. Collect additional investigative samples as necessary.</li><li>3. Inspect our water system facilities, including the treatment plant, for proper operation.</li><li>4. Interview staff to determine whether anything unusual was happening in the water system service area, especially since the previous month's sample(s).</li><li>5. Review new construction activities, water main breaks, and pressure outages that may have occurred during the previous month.</li><li>6. Review Cross-Connection Control Program status.</li><li>7. Discuss with DOH whether to issue a Health Advisory based on the findings of steps 3-6.</li></ol>

<b><i>E. coli</i>-Present Triggered Source Sample Response Plan – All Sources</b>
<p><b>If we have <i>E. coli</i> in any source water we will immediately:</b></p> <ol style="list-style-type: none"><li>1. Call DOH (Mark Stewart – (253) 512-7072).</li><li>2. Distribute required notice.</li><li>3. Interview staff.</li><li>4. In concert with DOH, begin work on corrective action plan. Corrective action options include discontinuing the use of the contaminated source, or providing 4-log virus treatment of the source.</li></ol>

## I. System Map

See Figure 1-1.



**APPENDIX C**

**ANNUAL OPERATING PERMIT**

**STATE OF WASHINGTON**  
**Public Water System**  
**Operating Permit**

The Department of Health Office of Drinking Water issues a permit to operate

OKANOGAN WATER DEPARTMENT, CITY OF (ID# 63200 M)

to owner: OKANOGAN, CITY OF County: OKANOGAN

┌ OKANOGAN, CITY OF ┐  
PO Box 752  
OKANOGAN, WA 98840  
└ ┘

This Permit is valid through May 2016

**PERMIT CATEGORY: \*\*\*\* Green \*\*\*\***

The permit category may be modified or the permit revoked subject to water system compliance with applicable State of Washington drinking water rules and regulations and the following statements:

The system operating permit color category is based on information on file with the Department at the time this permit was printed.

System is substantially in compliance with applicable drinking water requirements.



## **APPENDIX D**

### **SANITARY SURVEY AND DOH CORRESPONDENCE**



COPY RECEIVED  
NOV 3 2014

STATE OF WASHINGTON  
DEPARTMENT OF HEALTH  
EASTERN DRINKING WATER REGIONAL OPERATIONS  
16201 E Indiana Avenue, Suite 1500, Spokane Valley, Washington 99216-2830  
TDD Relay 1-800-833-6388

CITY OF OKANOGAN  
P.O. BOX 752  
OKANOGAN, WA 98840

October 30, 2014

Loren L. Howell, Water Manager  
City of Okanogan  
PO Box 752  
Okanogan, WA 98840

Subject: Okanogan Water Dept, City of; PWS # 63200M; Okanogan County  
Routine Sanitary Survey Inspection Report  
Survey Date - October 1, 2014

Dear Mr. Howell:

Thank you for your time and attention given to me during your recent sanitary survey. This letter documents the information collected during the survey. I listed defects in your water system facilities or operations that need your immediate attention below as *significant deficiencies* or *significant findings*.

### Significant Deficiencies

Significant deficiencies, if left unaddressed, have the potential of causing an immediate or potential risk to the health of the water system customer. **Congratulation, no significant deficiencies or findings were identified during this survey.**

During the survey, I inspected your four sources (Well #2, #3, #4, and #5), Reservoir #1 and #2, and the arsenic treatment facility. Prior to my visit, you inspected the North, East, and Highline Reservoirs (and provided photographs) to verify that the vents, overflow pipes, and hatches were in good condition.

We also discussed or reviewed the following items:

**Water Facilities Inventory (WFI) Form:** The WFI form is current and no update was needed at this time.

**Water Quality Monitoring:** At the time that I am writing this letter, the following source monitoring is required this year:

- Source S02 (Well #2) - VOC due in October.
- Source S03 (Well #3) - Nitrate due in July.
- Source S06 (Well #5) - Nitrate due in October.

Please note that you may have already completed this monitoring and it has not shown up yet in our database.

Loren Howell  
October 30, 2014  
Page 2

**Coliform Monitoring Plan (CMP):** The CMP has been updated to include all the sampling sites and Groundwater Rule source (triggered) monitoring requirements.

### **Cross-Connection Control (CCC) Program**

A review of your 2013 Annual Summary Report (ASR) shows that the City is doing a good job with its CCC program. The ASR shows the City serves eight high-hazard premises and all eight premises have proper premise isolation and were tested in 2013.

### **Emergency Response Program**

In response to the recent fire activity in Okanogan County, I recommend that the City review its water system's emergency response program to ensure that it is up to date and workable. Emergency response planning includes managers and system operators as they explore the system's vulnerabilities and establish procedures to follow in an emergency based on the system's priorities. You do not need to go it alone. Consider how you can involve community members or other groups who may be able to help you notify customers or provide other support. Consider forming partnerships with neighboring water systems and be familiar with local emergency response agencies.

By completing this sanitary survey, your water system met the requirements in WAC 246-290-416. We will notify you of your next sanitary survey in three to five years. Please note that satisfying the requirements of the sanitary survey should not be construed as meeting other applicable federal, state or local statutes, ordinances and regulations. Similarly, other DOH requirements should be addressed separately from the sanitary survey.

As provided by WAC 246-290-990(3)(c), a fee is charged to help recover the cost of conducting a sanitary survey. The Department of Health's total cost to complete this sanitary survey is \$968.84. The Office of Drinking Water has used state and federal funds to pay \$560.84 of this amount. An invoice showing the remaining amount due of \$408.00 is enclosed.

Please contact me at (509) 329-2117 if you have any questions regarding this letter.

Sincerely,



Michael D. Wilson, PE  
Regional Engineer  
Office of Drinking Water  
Division of Environmental Public Health

Enclosure: Sanitary Survey Invoice

cc: Okanogan Public Health  
Danielle Russell, Sanitary Survey Regional Coordinator

**APPENDIX E**

**CONSUMER CONFIDENCE REPORT**



**CITY OF OKANOGAN**  
**2015 Annual Drinking Water Quality Report**  
Public Water System ID 63200M

We want to keep you informed about the excellent water and services we have delivered to you this past year. Our goal is to provide to you a safe and dependable supply of drinking water. Our water source is from four ground water wells, drawn from the Okanogan River Aquifer, Well No 2 (SO2), Well No 3 (SO3), Well No.4 (SO4) and Well No 5 (SO6).

Our drinking water is safe and meets federal and state requirements. The City of Okanogan Water Department works 24/7 to provide top quality water to every tap, inform our valued customers about their water utility and help protect our water sources, which is the heart of our community and our future. To learn more, please attend regularly scheduled Council meetings on the first and third Tuesday of each month, 7:00 PM, at City Hall. Additional questions or comments about the City's water issues can be directed to the following contacts:

Environmental Protection Agency (EPA) Safe Drinking Water Act Hotline: 1-800-426-4791

State Department of Health (DOH) Office of Drinking Water: (509) 456-3115

City of Okanogan, 120 Third Avenue North, PO Box 752, Okanogan, WA 98840, Loren Howell, Water Manager, 422-3600

**Consumer Confidence Report Translation** "Este Informe contiene informacion muy importante. Traduscalo o hable con un amigo quien lo entienda bien."

We routinely monitor your drinking water for contaminants according to Federal and State laws to meet all regulatory requirements. This table shows the results of our monitoring for the period of January 1<sup>st</sup> to December 31<sup>st</sup>, 2014.

Drinking water, including bottled water, may reasonably be expected to contain small amounts of contaminants. The presence of these contaminants does not necessarily indicate that water poses a health risk. More information about contaminants and potential health effects can be obtained by calling the EPA's Safe Drinking Water Hotline (1-800-426-4791).

**TEST RESULTS**

Contaminant	Violation Y/N	Level Detected	Unit Measurement	SRL	MCLG	MCL	Likely Source of Contamination
<b>Inorganic Contaminants</b>							
Arsenic	N	.004-.0104	mg/L	.002	0.010	0.010	Erosion of natural deposits; runoff from orchards; runoff from glass and electronics production wastes.
Fluoride	N	0.02-0.61	mg/L	0.2	4	4	Erosion of natural deposits; water additive, which promotes strong teeth; discharge from fertilizer and aluminum factories.
Nitrate	N	0.32-1.01	mg/L	0.5	10	10	Runoff from fertilizer use; leaching from septic tanks; sewage; erosion of natural deposits.
Copper	N	0.165	mg/L	.02	1.3	AL=1.3	Corrosion of household plumbing systems; erosion of natural deposits.
Lead	N	0.003	mg/L	.002	0	AL=.015	Corrosion of household plumbing systems; erosion of natural deposits.
Turbidity	N	0.08-0.12	NTU	0.05	-	1.0	Soil runoff.
Sodium	N	10-23.6	mg/L	5.0	n/a	n/a	Occurs abundantly in nature in combined form.
Hardness	N	243-252.3	mg/L	10	n/a	n/a	Dissolved minerals in an aquifer.
<b>Microbiological Contaminants:</b> No detection of Coliforms, e-coli or fecal, present in water.							
<b>Radioactive Contaminants</b>							
Radium 226 & 228	N	0.80	pCi/l	1	0	5	Erosion of natural deposits
Alpha	N	2.31-3.73	pCi/l	3	0	15	Erosion of natural deposits
Uranium	N	2.37-5.32	ug/L	1	0	30	Erosion of natural deposits
<b>Synthetic Organic Contaminants:</b> No detection of SOCs at or above State Reporting Level, SRL.							
<b>Volatile Organic Contaminants:</b>							
Trichloroethane	N	0.3	ug/L	0.5	0	200	Improper disposal of metal parts degreaser
Dichlorodifluorom	N	0.6	ug/L	0.5	0	-	Improper disposal of refrigerators

*MCL's are set at very stringent levels. To understand the possible health effects described for many regulated contaminants, a person would have to drink 2 liters of water every day at the MCL level for a lifetime to have a one-in-a-million chance of having the described health effect.*

We have a source water protection plan available from our office that provides more information such as potential sources of contamination.

\*Arsenic Removal Plant 6th season in operation. The plant is removing the arsenic, results 6 ppb. \*Water Use Efficiency (WUE) for 2014, visit DOH web site for City of Okanogan Annual Water Use Efficiency report.

**Contaminant Type & Monitoring Requirements** *Asbestos* One-sample every 9 years in the distribution system. *Bacteriological Contaminants* Two samples per month in the distribution system. *Lead and Copper* Ten samples every 3 years at selected resident's tap. *Inorganic Chemicals* One sample every 3 years at source. Nitrates: One sample each year at source. *Radionuclides* The City tests for radionuclides and will continue to test every four years. *Synthetic Organic Chemicals* One sample every 3 years at each source. The City currently has a no detection-monitoring waiver. *Trihalomethanes* The City is not required to monitor for trihalomethanes but includes it in its VOC monitoring every 3 years. *Volatile Organic Chemicals* One sample every 3 years at each source, except for annual sampling required at Well 2.



**Definitions:** This table contains terms and abbreviations to help you better understand this report.

**Action Level (AL)** Concentration of lead or copper in water determines treatment requirements.

**Non-Detects (ND)** laboratory analysis indicates that the contaminant is not present.

**Parts per million (ppm)(Milligrams per liter) (mg/l)** one part per million corresponds to one minute in two years or a single penny in \$10,000.

**Parts per billion (ppb) (Micrograms per liter)** one part per billion corresponds to one minute in 2,000 years, or a single penny in \$10,000,000.

**Picocuries per liter (pCi/L)** - picocuries per liter is a measure of the radioactivity in water.

**Nephelometric Turbidity Unit (NTU)** is a measure of the clarity of water. Turbidity in excess of 5 NTU is just noticeable to a person.

**Treatment Technique (TT)** - A treatment technique is a required process intended to reduce the level of a contaminant in drinking water.

**Maximum Contaminant Level** - The "Maximum Allowed" (MCL) is the highest level of a contaminant that is allowed in drinking water. MCL are set as close to the MCLG as feasible using the best available treatment technology.

**Maximum Contaminant Level Goal (MCLG)** margin of safety level allowed of a contaminant in drinking water below which there is no known or expected risk to health.

**State Reporting Level (SRL)** the minimums detect level required by State to include in the Consumer Confidence Report.

**Water Use Efficiency (WUE)**

### **Helpful Definitions & Information**

**Microbiological Contaminants:** >**Total Coliform.** Coliforms are bacteria that are naturally present in the environment and are used as an indicator that other, potentially harmful, bacteria may be present. >**Fecal coliform/E. Coli.** Fecal coliforms and E. coli are bacteria whose presence indicates that the water may be contaminated with human or animal wastes. Microbes in these wastes can cause short-term effects, such as diarrhea, cramps, nausea, headaches, or other symptoms. They may pose a special health risk for infants, young children, and people with severely compromised immune systems. >**Turbidity.** Turbidity has no health effects. However, turbidity can interfere with disinfection and may provide a medium for microbial growth. Turbidity may indicate the presence of disease-causing organisms. These organisms include bacteria, viruses, and parasites that can cause symptoms such as nausea, cramps, diarrhea, and associated headaches.

**Radioactive Contaminants:** >**Alpha emitters.** Certain minerals are radioactive and may emit a form of radiation known as alpha radiation. Some people who drink water containing alpha emitters in excess of the MCL over many years may have an increased risk of getting cancer. **Inorganic Contaminants:** >**Arsenic.** Some people who drink water-containing arsenic in excess of the MCL over many years could experience skin damage or problems with their circulatory system, and may have an increased risk of getting cancer. >**Chlorine.** Some people who use water-containing chlorine well in excess of the MRDL could experience irritating effects to their eyes and nose. Some people who drink water containing chlorine in excess of the MRDL could experience stomach discomfort. >**Copper.** Copper is an essential nutrient, but some people who drink water-containing copper in excess of the action level over a relatively short amount of time could experience gastrointestinal distress. Some people who drink water containing copper in excess of the action level over many years could suffer liver or kidney damage. People with Wilson's disease should consult their personal doctor. >**Fluoride.** Some people who drink water containing fluoride in excess of the MCL over many years could get bone disease, including pain and tenderness of the bones. Children may get mottled teeth. >**Lead.** Infants and children who drink water containing lead in excess of the action level could experience delays in their physical or mental development. Children could show slight deficits in attention span and learning abilities. Adults who drink this water over many years could develop kidney problems or high blood pressure. >**Nitrate.** Infants below the age of six months who drink water-containing nitrate in excess of the MCL could become seriously ill and, if untreated, may die. Symptoms include shortness of breath and blue-baby syndrome.

**Volatile Organic Contaminants:** >**Dichloromethane.** Some people who drink water-containing dichloromethane in excess of the MCL over many years could have liver problems and may have an increased risk of getting cancer. >**1,1,1-Trichloroethane.** Some people who drink water containing 1,1,1-trichloroethane in excess of the MCL over many years could experience problems with their liver, nervous system, or circulatory system.

**General Health Effects Information** Nitrate in drinking water at levels above 10 ppm is a health risk for infants of less than six months of age. High nitrate levels in drinking water can cause blue baby syndrome. Nitrate levels may rise quickly for short periods of time because of rainfall or agricultural activity. If you are caring for an infant you should ask advice from your health care provider. Infants and young children are typically more vulnerable to lead in drinking water than the general population. It is possible that lead levels at your home may be higher than at other homes in the community as a result of materials used in your home's plumbing. If you are concerned about elevated lead levels in your home's water, you may wish to have your water tested and flush your tap for 30 seconds to 2 minutes before using tap water. Additional information is available from the Safe Drinking Water Hotline.

**Total Coliform:** The Total Coliform Rule requires water systems to meet a stricter limit for coliform bacteria. Coliform bacteria are usually harmless, but their presence in water can be an indication of disease-causing bacteria. When coliform bacteria are found, special follow-up tests are done to determine if harmful bacteria are present in the water supply. If this limit is exceeded, the water supplier must notify the public by newspaper, television or radio. To comply with the stricter regulation, we have increased the average amount of chlorine in the distribution system.

**Nitrates:** As a precaution we always notify physicians and health care providers in this area if there is ever a higher than normal level of nitrates in the water supply.

**Lead:** Lead in drinking water is rarely the sole cause of lead poisoning, but it can add to a person's total lead exposure. All potential sources of lead in the household should be identified and removed, replaced or reduced.

**Bottom Line:** Some people may be more vulnerable to contaminants in drinking water than the general population. Immune-compromised persons such as persons with cancer undergoing chemotherapy, persons who have undergone organ transplants, people with HIV/AIDS or other immune system disorders, some elderly, and infants can be particularly at risk from infections. These people should seek advice about drinking water from their health care providers. EPA/CDC guidelines on appropriate means to lessen the risk of infection by cryptosporidium and other microbiological contaminants are available from the Safe Drinking Water Hotline.

>Thank you for allowing us to continue providing your family with clean, quality water this year. In order to maintain a safe and dependable water supply we sometimes need to make improvements that will benefit all of our customers.

**APPENDIX F**

**CROSS CONNECTION CONTROL PROGRAM**

## **APPENDIX F**

### **CROSS CONNECTION CONTROL PROGRAM**

Okanogan Municipal Code (OMC) Section 13.10 addresses the Cross Connection Control Program (CCCP). The City of Okanogan uses “Cross-Track 5.2” computer software by Backflow Management Inc., for managing their CCCP. A copy of OMC 13.10 and a copy of the CCCP Manual with associated forms follow later in this appendix.

The City of Okanogan Public Works Water Department carries out the cross connection control program. A list of approved testers and specialists in the area is also attached.

Loren Howell, Water System Manager and Barry Featherly, Assistant Water System Manager are CCS certified.

When the City is requested to provide a new water service connection, the customer fills out a water service application questionnaire, and submits the construction drawings for the proposed development. The City reviews the questionnaire and submitted plans with respect to codes and regulations and the cross connection control program.

Records for the CCCP are recorded to a BMI Trac-5.2 computer based program and paper records are kept for backup as well.

CCCP Public Notice educational and awareness publications are sent with the utility billings.

The following documents consist of:

- Cross Connection Control Manual
- Okanogan Municipal Code Chapter 13.10, “Cross Connections”
- Cross Connection Control Field Inspection Form
- Cross Connection Control Plan Check
- List of Testing Locations
- Cross Connection Control Program Survey
- Water Service Application

### **CROSS CONNECTION CONTROL MANUAL**

#### **I. DEFINITIONS**

##### **A. Approved**

Accepted by the Building Inspector as meeting an applicable specification stated or cited in this regulation.

**B. Auxiliary Water Supply**

Any water supply to the premises other than the City's approved public potable water supply.

**C. Backflow**

The undesirable reversal of flow of water or other substances through a cross-connection and into the piping of a public water system or consumer's potable water system.

**D. Backflow Prevention Assembly**

The nomenclature "assembly" refers to a backflow preventer which is designed to be in-line tested and repaired, and to meet the head loss and flow requirements of the recognized approval authority. The "assembly" consists of the backflow prevention unit, two resilient seated shutoff valves, and test cocks.

**E. Backflow Prevention Device**

The nomenclature "device" refers to a backflow preventer that is not designed for in-line testing.

**1. Air Gap (AG)**

A physical separation between the free-flowing end of a potable water supply pipeline and the overflow rim of an open or non-pressurized receiving vessel. To be an "approved air gap," the separation must be at least twice the diameter of the supply piping measured vertically from the overflow rim of the receiving vessel, and in no case be less than one inch. When located within three pipe diameters (measured horizontally) of a wall, the separation must be at least three times the diameter of the supply piping or four times the diameter of the supply piping for intersecting walls.

**2. Atmospheric Vacuum Breaker (AVB)**

A device that contains a float check (poppet), a check seat and an air inlet vent. When water pressure is reduced to a gauge pressure of zero or below, the float check drops, allowing air to enter the device, preventing backsiphonage. It is designed to prevent backsiphonage only.

**3. Double Check Valve Assembly (DCVA)**

An approved assembly consisting of two independently operating check valves, loaded to the closed position by springs or weights, and installed as a unit with, and between, two resilient seated shut-off valves and having suitable connections for testing.

**4. Pressure Vacuum Breaker Assembly (PVBA)**

An approved assembly consisting of a spring loaded check valve loaded to the closed position and installed as a unit with, and between, two resilient seated shut-off valves and having suitable connections for testing. It is designed to protect against backsiphonage only.

**5. Reduced Pressure Backflow Assembly (RPBA)**

An approved assembly consisting of two independently operated check valves, spring loaded to the closed position, separated by a spring loaded differential pressure relief valve loaded to the open position, and installed as a unit with, and between, two resilient seated shut-off valves and having four suitable test cocks for checking the water tightness of the check valves and the operation of the relief valve.

**F. Backpressure**

Backflow due to increased pressure above the supply pressure caused by pumps, gravity, or other sources of pressure.

**G. Backsiphonage**

Backflow due to negative or subatomic pressure in the distribution system.

**H. City**

The City of Okanogan or their duly authorized representative.

**I. Contamination**

An impairment of the quality of the potable water which creates an actual hazard to the public health through poisoning or through the spread of diseases by sewage, industrial fluids, or waste. Also defined as severe or high hazard. Also see *Pollution*. The term “contamination” used in EPA and state drinking water regulations “maximum contamination level” bestows a different meaning than that used in describing a cross-connection hazard.

**J. Cross-Connection**

Any actual or potential physical connection between a public water system and any source of non-potable liquid, solid or gas that could contaminate the public water supply by backflow.

**K. Customer**

For purposes of cross-connection control, the owner or operator of a plumbing system connected to a public water system via a service connection.

**L. Director**

The Director, or delegated representative, in charge of the City of Okanogan Department of Public Works.

**M. In-Premise Protection**

A method of backflow prevention in which a backflow prevention assembly is installed on the customer's internal water supply line prior to a fixture, piece of equipment or area that has been determined to have backflow potential. This shall effectively isolate the fixture, piece of equipment or area from the rest of the customer's distribution system.

**N. Owner**

Any person who has legal title to, or license to operate or occupy, a property upon which a cross-connection inspection will be made or upon which a cross-connection is present.

**O. Person**

Any individual, partnership, company, public or private corporation, political subdivision, or agency of the State or the United States or any other legal entity.

**P. Pollution**

An impairment of the quality of the potable water supply which does not create a hazard to the public health but which does adversely affect the aesthetic qualities of such potable waters for domestic use. Also defined as low hazard. See also *Contamination*.

**Q. Premise Isolation**

A method of protecting a public water system by installation of approved air gaps or approved backflow prevention assemblies at or near the service connection to isolate the customer's plumbing system from the purveyor's distribution system.

**R. Purveyor**

The Purveyor or delegated representative in charge of the City of Okanogan's water system.

**S. Reclaimed Water**

Effluent derived in any part from sewage from a wastewater treatment system that has been adequately and reliably treated, so that as a result of that treatment, it is suitable for a direct beneficial use or a controlled use that would not otherwise occur and is no longer considered wastewater.

**T. Water Service Entrance**

The point in the Owner's water system beyond the sanitary control of the City, generally considered to be the outlet end of the water meter and always before any unprotected branch.



## **II. PURPOSE AND SCOPE**

- A. This Manual establishes minimum standards for the City to protect the public potable water supply from possible contamination of pollution due to backflow or backsiphon from a customer's private internal system into the public potable water system.
- B. This Manual establishes minimum cross-connection control operating policies, provides guidelines and requirements for installation, testing, and maintenance of approved backflow prevention assemblies, and establishes permitting and inspection requirements for existing and new backflow prevention assemblies.
- C. The purpose of this Manual is not to create or otherwise establish or designate any particular class or group of persons who will or should be especially protected or benefited by the terms of this Manual.

## **III. AUTHORITY**

- A. The Federal Safe Drinking Water Act of 1974 (and amendments of 1996), the statutes of the State of Washington Title 43 RCW and Chapter 246-290-490 WAC require purveyors to "protect public water systems from contamination due to cross connections."
- B. City of Okanogan Municipal Code, Chapter 13.10 regulates cross-connections.

## **IV. RESPONSIBILITY**

- A. The Director shall be responsible for administering the provisions of this Manual.
- B. If the Director determines, consistent with the provisions of this Manual, a backflow prevention assembly is required at any Customer's premises, the Director, or his delegated agent, shall give notice to the Customer to install an air gap or approved backflow prevention assembly which isolates the customer's plumbing system from the City's distribution system.
- C. Installation of required backflow protection assemblies shall be a condition of continued water service from the City. Service from the City's water supply system to any premises upon which the potential for backflow into the City's system exists shall be discontinued or refused unless corrective action is taken in accordance with this Manual.
- D. Upon installation, the customer shall have the backflow prevention assembly tested once each year by a certified backflow assembly tester



(BAT). The customer shall notify the Director in advance of the test so that a City representative can witness the test if desired. Records of the test and any required repair shall be submitted to the City within 30 days.

## **V. FAILURE TO COMPLY – VIOLATIONS - PENALTIES**

Any person, firm, or corporation who willfully violates any provisions and requirements of this Manual, or the City municipal code shall be subject to discontinuance of supply of City water to the premise where the violation exists. Discontinuance of the City potable water supply to the premise shall remain in effect until corrective action, as required by the Director is completed, tested, and approved.

## **VI. REQUIREMENTS**

### **A. GENERAL**

1. Compliance with the provisions of the City of Okanogan's Cross Connection Control Manual shall be a condition of receiving the City's water supply.
2. It is unlawful for any person to allow any contaminants or pollutants to backfeed from their facility and/or property into the City distribution system. Any connections now existing or hereafter installed that could allow for backfeed or any contaminants or pollutants into the City's distribution system shall be disconnected and/or eliminated. Connections which cannot be disconnected and/or eliminated shall require the installation of a State of Washington approved backflow protection assembly that shall be regularly inspected and tested in accordance with the City's Cross Connection Control Manual.
3. When the City requires that the public water supply be protected by premise isolation, the Owner shall be responsible for water quality beyond the outlet end of the premise isolation assembly and should utilize fixture isolation protection for that purpose. Fixture isolation assemblies shall be installed in accordance with the Uniform Plumbing Code.
4. The City may allow that the public water supply be protected by fixture isolation for existing customer connections. Such an allowance shall only be permitted so long as the Director determines that the level of protection is adequate to protect the City's distribution system, and the Owner agrees, in writing (unless waived by the City) to: (1) implement and maintain the fixture isolating backflow protection to the satisfaction of the City, and (2) comply with all applicable plumbing codes, including permitting requirements.

## B. CITY OF OKANOGAN

1. On new installations, the City will provide on-site evaluation and/or inspection of plans in order to determine the type of backflow prevention assembly, if any, that will be required.
2. For premises existing prior to the start of this program, the City will perform evaluations and inspections of plans and/or premises and inform the Owner by letter of any corrective action deemed necessary, the method of achieving the correction, and the time allowed for the correction to be made. Up to sixty days will be allowed; however, this time period may be shortened by the Director depending upon the degree of hazard involved and the history of the device(s) in question.
3. Premises are subject to inspection on or after the expiration date or required action to correct a cross-connection. Premises that have failed to comply with the City's request shall receive written notice, via registered mail, that their water service to the premise will be terminated within a period not to exceed thirty (30) calendar days.
4. In the event the Owner informs the City of extenuating circumstances as to why the correction has not been completed, the City may grant a time extension, up to, but not exceeding sixty (60) days.
5. If the City determines at any time that a serious threat to the public health exists, the water service shall be terminated immediately, provided, that notice will be posted on the premises affected at the time said service is terminated.
6. Inspection shall be done during the initial installation, during on-site reviews of existing installations, and after any relocation.
7. When an initial installation or test identifies a backflow prevention assembly is not properly functioning, the Owner shall correct the malfunction and have the assembly inspected and re-tested until the backflow device operates correctly.

## C. OWNER

1. The Owner shall be responsible for the elimination or protection, by an air gap or approved backflow prevention assembly, of all cross-connections on their premises.

2. The Owner after having been informed by a letter from the City shall, at their expense, install and maintain any and all required backflow prevention assemblies.
3. The Owner shall, at their expense, be responsible for having all backflow assemblies tested: (1) at the time of installation, (2) annually after installation, or more frequently if tests indicate repeated failures to meet test criteria; and (3) after an assembly is repaired, reinstalled or relocated or an air gap is re-plumbed or replaced by an approved RPBA. The test shall be performed by a State of Washington certified Backflow Assembly Tester (BAT) and signed by the Owner. The results of the test shall be reported within 30 days to the Director on a form provided by or approved by the City.
4. The Owner shall, immediately, or no later than 30 days, or otherwise as directed by the Director, correct any malfunction of the backflow preventer which is revealed by periodic testing.
5. The Owner shall inform the City of any proposed or modified cross-connection and also any existing cross-connections of which the Owner has actual knowledge but has not been found by the City.
6. The Owner shall install only backflow prevention assemblies approved by the City.
7. Any Owner having a private well or other private water source shall not cross-connect to the City's system.
8. The Owner shall provide access of the premises to the City at the City's request. Failure to provide access to inspect facilities shall be grounds for termination of water service.
9. The Owner shall be responsible for the payment of all fees for permits, annual or semi-annual device testing, re-testing in the case that the assembly fails to operate correctly, and any re-inspection for non-compliance with City requirements. Permits and fee schedules shall be as specified in the applicable sections of the City of Okanogan's municipal code.

## **VII. INSTALLATION AND TESTING – MINIMUM REQUIREMENTS**

- A. Minimum requirements for the installation and testing of all backflow protection assemblies shall be in accordance with the Cross Connection Control Manual – Accepted Procedure and Practice produced by the Pacific Northwest Section, American Water Works Association (PNWS/AWWA), Sixth Addition, December 1995, including subsequent

revisions adopted by reference herein. A copy is available for viewing at the Public Works Department of the City of Okanogan, additional copies can be purchased from the PNWS/AWWA.

- B. In addition, all backflow protection assemblies shall be installed at a location that is easily accessible for inspection and testing. Assemblies located in vaults shall have adequate clearances and depths to allow the City to inspect and test. Assemblies that cannot be easily and readily inspected shall be required to be relocated and re-plumbed as required by the City. The Owner shall contact the City for applicable installation requirements and standards.
- C. All bypass lines parallel to a line on which a backflow prevention assembly is installed shall have an approved backflow prevention assembly installed that is equal in type to the assembly required by the City on the main line.

#### **VIII. BACKFLOW PROTECTION DEVICES**

- A. All backflow protection assemblies (RPBAs, RPDAs, DCVAs, DCDAs, PVBAs and AVBs) installed for protection of the public water supply shall be models included on the current approved DOH backflow prevention assemblies list titled “Backflow Prevention Assemblies Approved for Installation in Washington State” or other such agency acceptable to the Director. A copy is available for viewing at the Public Works Department of the City of Okanogan, additional copies can be requested from the DOH.
- B. Any existing backflow protection assembly in use, but not currently listed by DOH, can continue to be used, provided all the following conditions are met:
  - 1. The assemblies were included on the City and/or DOH list of approved backflow prevention assemblies at the time of installation;
  - 2. The assemblies have been properly maintained;
  - 3. The assemblies are functioning properly based on inspection by the City and testing by a certified Backflow Assembly Tester;
  - 4. The degree of protection is satisfactory for protection of the City’s water system as determined by the Director.
- C. When an unlisted assembly does not meet the above conditions, is moved, or cannot be repaired using spare parts from the original manufacturer, the

assembly shall be replaced by an assembly currently listed as approved by the DOH or other such agency acceptable to the Director.

## IX. APPLICABILITY

- A. The provisions of this Manual are applicable to all connections of the City's water supply. The City recognizes there are varying degrees of risks associated with different types of uses and will consider this when determining if a cross connection exists and when determining an applicable backflow prevention assembly.
- B. The following tables, Tables F-1, F-2, F-3, and F-4 are derived from the Pacific Northwest Section – American Water Works Association's Cross Connection Control Manual, Accepted Procedures and Practices, Sixth Addition, December 1995. These tables, subject to revisions, provide minimum requirements and guidance for the assessment of the degree of hazard and required level of protection. If the actual degree of hazard is determined, by the Director to be higher than these tables indicate, a higher level of protection may be required.

**Table F-1** Summarizes the relative level of protection provided by the different categories of assemblies and devices.

**Table F-2** A list of customer categories or types of water use where premise isolation is required in all cases.

**Table F-3** A list of customer categories or types of water use where premise isolation is required for existing service connections in accordance with the provisions of Section VI, GENERAL, D. of this Manual.

**Table F-4** A list of some of the fixtures, equipment or uses of water which may constitute a cross connection and the minimum level of protection required.

**Table F-1  
Relative Level of Protection**

<b>Abbreviations</b>	<b>Description/Application Summary<sup>(1)</sup></b>	<b>Relative Level of Protection<sup>(2)</sup></b>
AG	Approved Air Gap For high and low health hazards, backpressure, and backsiphonage	1
RPBA	Reduced Pressure Backflow Assembly	2
RPDA	Reduced Pressure Detector Assembly For high and low health hazards, backpressure, and backsiphonage	
DCVA	Double Check Valve Assembly	3
DCDA	Double Check Detector Assembly For low health hazards only, backpressure and backsiphonage	
PVBA	Pressure Vacuum Breaker Assembly	4
SVBA	Spill-Resistant Vacuum Breaker Assembly For high and low health hazards, backsiphonage only	
AVB	Atmospheric Vacuum Breaker	5
HBVB	Hose Bib Vacuum Breaker	
LFVB	Lab Faucet Vacuum Breaker For very low health hazards, and backsiphonage only	
DCAV	Dual Check Valve with Atmospheric Vent	
DCV	Dual Check Valve or Meter Check Valve (Dual) For very low health hazards, backpressure and backsiphonage	

(1) The above description of applicable and relative level of protection is based on the perspective of the City's selection of assemblies and devices for the prevention of the contamination of the water distribution system. Plumbing codes may classify some devices as providing higher levels of protection and as suitable for both backpressure and backsiphonage.

(2) This Manual does not address the location, inspection, and testing of AVB's, HBVB's, LFVB's, DCAV's and DCV's.

**Table F-2  
Mandatory Service Isolation**

<b>Category of Premise or Use of Water</b>	<b>Assessed Health Hazard</b>	<b>Minimum Protection Recommended at Meter</b>
Radioactive Material Processing Plants or Nuclear Reactors	Severe	RPBA & AG
Sewer Treatment Plants or Sewage Pump Station	Severe	RPBA & AG
Hospitals, Medical Centers, Medical/Dental or Vet Clinics, Plasma Centers, Blood Plasma Centers, Nursing Homes	High	RPBA
Mortuaries	High	RPBA
Laboratories	High	RPBA
Metal Plating Industries	High	RPBA
Petroleum Processing or Storage Plants	High	RPBA
Food Processing and Beverage Bottling Plants, Canneries, Packing (Slaughter) Houses	High	RPBA
Film Processing Facilities	High	RPBA
Piers and Docks, Graving Docks, Boat Marinas, Dry Docks	High	RPBA
Commercial Laundries and Dry Cleaners	High	RPBA
Premises Restricting Inspection	High	RPBA
Premises with Unapproved Auxiliary Supply, Including Reclaimed Water		
New	High	RPBA
Existing		
Interconnected with Potable Water Supply	High	RPBA
Not Interconnected with Potable Water Supply	Low	DCVA
Premises with Approved Auxiliary Supply	Low	DCVA
Car Washes	High	RPBA
Premises with Fire Sprinkler Systems and/or Private Hydrants		
With Chemical Addition	High	RPBA/RPDA
Without Chemical Addition	Low	DCVA/DCDA
Tall Buildings (Over 30 feet) – Elevation Above the Connection Between the Service Line and the Distribution System	Low	DCVA
Irrigation Systems – Individually Metered and Supplied by Domestic Water Supply		
With Chemical Addition	High	RPBA
Without Chemical Addition	Low	DCVA



**Table F-3  
Recommended Service Isolation**

Category of Premise or Use of Water	Assessed Health Hazard	Minimum Protection Recommended at Meter
Battery Manufacturing/Repair Facilities	High	RPBA
Ice Manufacturing and Cold Storage Plants	High	RPBA
Residential Irrigation	Low	DCVA

**Table F-4  
Recommended Protection at Fixture and Equipment**

Description of Fixture, Equipment or Use of Water <sup>(1)</sup>	Assessed Health Hazard	Minimum Protection at Fixture	Additional Premise or Internal Isolation <sup>(2)</sup>
Air Compressor	Low	DCVA	
Air Conditioning Systems	High	RPBA	
Air Washers	High	RPBA	
Aquarium, Make-Up Water	High	AG/RPBA	
Aspirators, Medical/Lab	High	AVB	RPBA
Aspirators, Medical/Lab	High	RPBA	
Aspirator, Weedicide, Herbicide, and Pesticide	High	RPBA	
Aspirator, Vault Drain	High	RPBA	
Autoclave	High	RPBA	
Autopsy Table	High	RPBA	
Baptismal Fountain	High/Low	RPBA, AG/AVB	
Bathtub, Below Rim Filler	High	RPBA	
Bedpan Washer	High	RPBA	
Post-Mix Beverage Dispenser Using CO <sub>2</sub>	High	RPBA	
Bidets	Low	AVB	
Boiler Feed Lines	High	RPBA	
Bottle Washing Equipment	High	RPBA	
Bottle Washing Equipment	High	PVBA/AVB	RPBA
Box Hydrant (Irrigation)	High	PVBA/DCVA	
Brine Tank	Low	AG/DCVA	
Can Washing Equipment	High	RPBA	
Can Washing Equipment	High	PVBA/AVB	RPBA
Chemical Feed Tank for Industrial Process	High	AG/ RPBA	RPBA
Chemical Feeder for Commercial Cleaners	High	AG/ RPBA	RPBA/DCVA
Chemical Feeder for Commercial	High	AVB/PVBA	

Cleaners			
Chlorinators	High	RPBA	
Commercial Coffee Urns	Low	AG/AVB	
Computer Cooling Lines	High	RPBA	
Condensation Tanks	High	RPBA	
Commercial Cooling Kettles	Low	AG/AVB	
Cooling Towers	High	AG/ RPBA	
Decorative Ponds	High	AG/ RPBA	
Degreasing Equipment	High	RPBA	
Dental Equipment/Cuspidors	High	RPBA	RPBA
Dialysis Equipment	High	RPBA	
Dishwashers	Low	AVB	
Drinking Fountains	Low	AG	
Dye Vats and Tanks	High	AG/ RPBA	
Etching Tanks	High	AG/ RPBA	RPBA
Fermenting Tanks	High	AG/ RPBA	RPBA
Fertilizer Injection	High	RPBA	
Film Processors	High	RPBA	
Fire Department Connection	Low	DCVA	
Fire Sprinkler System without Chemical Addition	Low	DCVA/DCDA	
Fire Sprinkler System with Chemical Addition	High	RPBA/RPDA	
Floor Drains	High	AG	
Flushing Floor Drains	High	AVB	DCVA
Fume Hoods	High	AVB	RPBA
Garbage Can Washers	High	RPBA	
Heat Exchangers Other than Double Wall with Leak Path	High	RPBA	
Heat Pumps	High	RPBA	
High Pressure Washers without Chemical Injection	Low	DCVA	
Hose Bibs (Residential)	Low	AVB/HBVB	
Hose Bibs (Industrial)	Varies	AVB/HBVB	RPBA/DCVA
Hoses, Kitchen Rinse	Low	AVB	
Hot Tubs	High	AG/RPBA	
Commercial Hot Water Heating Boilers	High	RPBA	
Hydrotherapy Baths	High	RPBA	
Ice Makers	High	AG/RPBA	
Industrial Fluid Systems	High	RPBA	
Intertied (Looped) Services	Low	DCVA	
Irrigation System (Lawn) with Chemical Addition	High	RPBA	
Irrigation System (Lawn) without Chemical Addition	Low	PVBA/DCVA	

Janitor Sinks	Low	AVB/HBVB	
Kitchen Equipment	Low	AVB	
Laboratory Equipment	High	AVB/LFVB	RPBA
Laundry Machines, Commercial	High	RPBA	
Livestock Drinking Tanks	High	AG/AVB	DCVA
Make-Up Tanks	High	AG/ RPBA	
Mobile Carpet Cleaners	High	RPBA	
Pesticide Applicator Trucks	High	AG/RPBA	
Photo Developing Sinks/Tanks	High	RPBA	
Private Fire Hydrants	Low	DCVA	
Pump Prime Lines	High	RPBA	
Radiator Flushing Equipment	High	RPBA	
Recreational Vehicle Dump Station	Severe	AG	RPBA
Sewer Connected Equipment	Severe	AG	
Sewer Flushing	Severe	AG	
Spas	High	AG/RPBA	
Steam Generating Equipment	High	RPBA	
Sterilizers	High	RPBA	
Stills	High	RPBA	
Sumps	High	AG	
Swimming Pools	High	AG/RPBA	
Trap Primers	High	AG	
Used or Gray Water Systems	High	RPBA	
X-Ray Equipment	High	RPBA	

- (1) The information in Table F-4 may differ from the backflow prevention requirements for individual plumbing fixtures found in plumbing codes. For public health protection within a customer’s premise, the Uniform Plumbing Code governs. Table F-4 is provided to illustrate only some of the health hazards found in plumbing systems. This table will be used by the City in assessing the degree of hazard a customer’s plumbing system places upon the City’s water distribution system. Deficiencies in backflow prevention within the customer’s premise should be compensated for through the selection of an appropriate assembly for premise isolation.
- (2) Where a high health hazard is assessed, the use of an atmospheric vacuum breaker or other backflow device for protection at a fixture should only be allowed when area or premise isolation is provided by an approved backflow assembly.

**X. ADMINISTRATIVE PROCEDURES**

The City of Okanogan is in compliance with DOH cross connection control requirements. No additional administrative procedures are necessary to correct the existing program.

The following requirements are based on the most current edition of the Cross Connection Control Manual published by the PNWS-AWWA. These requirements are provided for clarification and in any disagreement between these listed below and requirements listed elsewhere in this Manual, the more restrictive shall govern. As described elsewhere in this Manual, the premise

isolation requirements may be waived or reduced for certain existing businesses, providing certain conditions are met.

## **1. Minimum Requirements**

### **A. RPBA's**

1. Premises on which materials dangerous to health or wherein toxic substances are handled, shall be required to have an approved reduced backflow assembly installed at the service connection.
2. Premises where entry is physically restricted so that inspections for cross connections cannot be made sufficient to assure that cross connections do not exist, shall be required to have an approved reduced pressure backflow assembly installed at the service connection.
3. Premises having an auxiliary water supply with internal cross connections that are not correctable, or intricate plumbing arrangements which make it impractical to ascertain whether or not cross connections exist, shall be required to have an approved reduced pressure backflow assembly installed at the service connection.

### **B. DCVA's**

1. Premises which handle a substance that is objectionable, although not a health hazard, in a manner constituting a potential cross connection, shall be required to have an approved double check valve assembly installed at the service connection.
2. Premises having an auxiliary water supply with no known cross connections shall be required to have an approved double check valve assembly installed at the service connection.
3. Premises on which any substance that is not a health hazard but is under pressure so as to enable entry into the public water supply or where a cross connection could reasonably be expected to be present, shall be required to have an approved double check valve assembly installed at the service connection.
4. Premises which have a repeated history of cross connections being established or re-established, shall be required to have an approved double check valve assembly installed at the service connection.

### **C. Fire Protection Systems**

1. Premises having a fire protection system where no chemicals are allowed to be used shall be required to have an approved double check valve assembly (DCVA) or approved double check detector assembly (DCDA) installed at the fire service connection.
2. Residential premises having a fire protection system where no chemicals are allowed to be used, shall be required to have an approved double check valve assembly (DCVA) installed at the water service connection.
3. Residential fire systems with a flow through system using approved potable water pipe and materials shall not be required to install backflow protection.

D. Irrigation Systems

1. Premises having an irrigation system where chemicals or herbicides are allowed to be used, shall be required to have an approved reduced pressure backflow assembly installed at the service connection.
2. Non-residential premises having an irrigation system which is subject to flooding, backpressure, elevated piping or where compressed air is allowed to be used, shall be required to have an approved double check valve assembly installed at the service connection.
3. Non-residential premises having an irrigation system which does not fall into one of the prior categories, shall be required to have an approved pressure vacuum breaker assembly or double check valve assembly installed on the system.

**2. New and Proposed Construction**

- A. Upon application for a building permit, the Building Official or authorized designate shall require detailed plans and specifications for the plumbing installation. The customer shall also be required to complete a Cross Connection Control Program Survey.
- B. The Building Official, or authorized designate, shall review these plans, specifications, and survey to determine the probability of cross connections, the availability of auxiliary water supply, and the handling of substances which, if introduced into the water supply, would constitute a health, plumbing, or system hazard.

- C. During the construction phase of any new building, structure, or ground installation, and during the plumbing inspection, the Building Official or authorized designate will also perform the required cross connection control inspection. Upon completion of the plumbing inspections, the Building Official or authorized designate shall complete the Cross Connection Control Field Inspection Form (shown at the end of the Appendix), to document that subject cross connection control inspection has been made and to document the location of any and all backflow prevention assemblies and/or devices.
- D. All backflow prevention assemblies installed internally or at the service connection shall be tested by a certified Backflow Assembly Tester and the test reports submitted to the Building Official or authorized designate (using the Backflow Assembly Test Report form shown at the end of the Appendix).

### **3. Existing Building, Structures, and Grounds**

A systematic program of inspection has been established with priority given on the basis of risk to public health and is conducted as outlined below.

- A. A form letter will be sent to each commercial and industrial metered customer explaining the program and stressing the relationship between cross connections, water-borne disease epidemics and types of health hazards. The duties and liabilities of the Owners or Managers as well as the rules and regulations that apply, will be explained. The letter will also include a questionnaire of desired information such as the type of water used on the premises, auxiliary water supplies, chemicals used, and certain types of fixtures installed. These questionnaires are to be returned to the Building Official or authorized designate.
- B. Based on the known information of the customer's operation and the information received on the questionnaire, an inspection schedule will be prepared based on the location of the hazard within the facility and the degree of hazard posed to the utility.
- C. Approximately 10 days prior to the scheduled date of inspection, the City will contact the Owner requesting an appointment with the Owner/Manager of the premises to discuss the necessity for the inspection and other pertinent matters.
- D. On the appointed date, the Building Official or authorized designate will meet with the Owner/Manager and explain the purpose of the inspection. The Building Official or authorized designate will suggest

the Owner/Manager appoint an individual from his firm that is knowledgeable with the firm's plumbing system to accompany the inspectors. At this time, the Building Official or authorized designate can obtain any blue prints or drawings of the "in-plant" systems that are available and discuss any questions or other problems the Owner/Manager may have.

- E. On the date of the scheduled inspection, the City of Okanogan's Inspector, with the Owner's representative, will make a complete physical survey of all exposed piping. The underground system is to be checked as accurately as possible. All lines will be sketched on a field drawing, except where intricate plumbing arrangements make it impractical. In this case an "as-built" drawing will be requested. Each line shall be followed to its end and a survey made to determine whether there are any actual or potential cross connections or any conditions that might tend to pollute the potable water system.
- F. Immediately upon completion of the survey, the inspection team will orally brief the Owner/Manager of their findings.
- G. The inspection team will prepare a written report that will include, but shall not be limited to, the following:
  - 1. Complete identifying information;
  - 2. All cross connections found, their location and optional methods of control;
  - 3. All industrial fluids, chemicals, or other contaminating liquids used or pumped under pressure and their use and probability of cross connections;
  - 4. Any applicable drawings, sketches, blueprints or other documents used in support of the inspection;
  - 5. Summary of findings;
  - 6. Specific recommendations.
- H. The inspection team will submit a copy of the completed report to the Building Official or authorized designate.
- I. Upon completion of the review of the report, the Building Official or authorized designate shall prepare a letter to the respective customer. The letter will outline the findings of the report, the corrective action required, and establish a corrective action completion date (usually 60



days). A copy of the report will be maintained on file for review by the State Department of Health.

- J. On the corrective action completion date, or soon thereafter, the Inspector shall take a copy of the report and re-inspect the items that required corrective action.
- K. Upon completion, the Inspector shall report in writing to the Building Official or authorized designate, the results of the re-inspection.
- L. After receiving the results of the re-inspection the Building Official or authorized designate shall take such action as deemed appropriate under the provisions of the City's Cross Connection Control Manual.
- M. When all required actions have been completed and the device(s) tested by a certified Backflow Assembly Tester, a letter shall be sent to the Owner. Said letter will inform them of the annual testing requirements, including maintaining all backflow prevention devices in proper operating order as evidenced by submission, to the city, of the annual testing report.

#### **4. Residential Education and Awareness**

The City may develop or acquire pamphlets and/or bill stuffers to send to all of the water system customers. These shall include, but are not limited to, the following subjects:

- A. Home irrigation safety;
- B. Residential fire sprinkler systems;
- C. Health hazards associated with hose connections (chemical sprayers, radiator flush kits, etc.), utility sinks, and other household dangers

If the City develops this program, this information shall be mailed directly to the customers.

The City shall also take advantage of other opportunities for public education by developing a traveling exhibit that can be set up at community events, schools, and at City Hall.

#### **5. Registering of Certified Testers**

The City will maintain a list of Backflow Assembly Testers (BATs) that may be provided to customers. Persons or organizations wishing to be

added to this list will be required to provide the City with copies of the following:

- A. Proof of current certification by the State of Washington as a BAT for all persons that are authorized to perform tests.
- B. Proof of current calibration tests performed for all testing equipment (annual calibration is required).
- C. A copy of a current business license authorizing the company to work in the City of Okanogan.

## **6. Record Keeping and Tracking of Assemblies**

The City maintains records that meet all of the record keeping requirements of the State and allow effective monitoring and tracking of customer compliance with the annual backflow assembly testing and requirements. The general content of the City's records are as follows:

Information on each assembly will include:

- A. Location of the business (or water service).
- B. Location on premises (some businesses may have multiple devices).
- C. Initial inspection information for each location (inspector, date, survey number, comments).
- D. Installation information (installed by, contact information, date installed, specific location, water line size, water pressure, hazard level and hazard protected).
- E. Assembly information (assembly number, type, manufacturer, size, model, serial number and inspection period).
- F. Complete testing history (initial and final test results for each year with: pass/fail, test type, date, tester's name and certification number, line pressure and test results for all three valves, repair information, test kit information and Owner's signature).

## Chapter 13.10

### CROSS CONNECTIONS

#### Sections:

- 13.10.010 Definitions.
- 13.10.020 Purpose.
- 13.10.030 Cross connections regulated.
- 13.10.040 Backflow prevention device requirement.
- 13.10.050 Installation requirements.
- 13.10.060 Access to premises.
- 13.10.070 Variances.
- 13.10.080 Costs of compliance.
- 13.10.090 Termination of service.

#### 13.10.010 Definitions.

A. "Okanogan" means city of Okanogan.

B. "Cross connection" means any physical arrangement where a public water system is connected, directly or indirectly, with any other nondrinkable water system or auxiliary system.

C. "Backflow" means the flow in the direction opposite to the normal flow or the introduction of any foreign liquids, gases, or substances into the water system of Okanogan.

D. "Auxiliary supply" means any water source or system other than the public water system that may be available in the building or on the premises.

E. "Approved backflow prevention device" means a device to counteract back pressures or prevent back siphonage. This device must appear on the list of approved devices issued by the Washington State Board of Health.

F. "Reduced pressure principle device" shall mean an assembly containing two independently acting approved check valves together with a hydraulically operated, mechanically independent, differential relief valve located between the check valves and at the same time below the first check valve. The device shall include properly located test cocks and tightly closing shut-off valves at the end of the assembly. A check valve is approved if it

appears on the list of approved devices issued by the Washington State Board of Health.

G. "Premises" means any piece of land to which water is provided including any structure, improvement, or mobile home located on it. (Ord. 788B § 1:01, 1994)

#### 13.10.020 Purpose.

The purpose of these regulations is to protect the water supply of Okanogan from contamination or pollution due to any existing or potential cross connections. (Ord. 788B § 1:02, 1994)

#### 13.10.030 Cross connections regulated.

No cross connections shall be created, installed, used or maintained within the territory served by Okanogan, except in accordance with these regulations. (Ord. 788B § 1:03, 1994)

#### 13.10.040 Backflow prevention device requirement.

A. Approved backflow prevention devices shall be installed at the expense of the user, at the service connection or within the premises, as determined by a certified cross connection inspector employed by the city in each of the following circumstances, appropriate to counter the degree of hazard:

1. If the nature and extent of any activity on the premises, or the materials used in connection with any activity on the premises, or the materials stored on the premises, could contaminate or pollute the drinking water supply;
2. On premises having any one or more cross connections;
3. Internal cross connections that are not correctable, or intricate plumbing arrangements which make it impractical to ascertain whether cross connections exist;
4. A repeated history of cross connections being established or reestablished;
5. Unduly restricted entry so that inspections for cross connections cannot be made with sufficient frequency or with sufficient

notice to assure that cross connections do not exist;

6. Materials of a toxic or hazardous nature being used such that if back-siphonage should occur, a health hazard could result;

7. Any mobile apparatus which uses the city's system or water from any premises within the city;

8. On any premises where installation of an approved backflow prevention device is deemed to be necessary to accomplish the purpose of these regulations in the judgment of a certified cross connection inspector employed by the city; and

9. On premises where auxiliary water systems are in place.

B. If a cross connection cannot be eliminated, then the following backflow prevention devices are approved for use by the city:

1. An air gap separation, reduced pressure principle backflow prevention assembly (RPBA) or a reduced pressure principle detector backflow prevention assembly (RPDA) shall be installed if the cross connection creates an actual or potential health or system hazard.

2. An air gap separation, RPBA, RPDA, double-check valve backflow prevention assembly (DCVA), or double-check detector backflow prevention assembly (DCDA) shall be installed if the cross connection is objectionable, but does not pose an unreasonable risk to health.

3. A pressure vacuum breaker assembly (PVBA) or an atmospheric vacuum breaker may be installed where the substance that could backflow is objectionable or back pressure is present in the downstream piping.

4. Backflow prevention assemblies, appropriate for the degree of hazard or air gaps and in some cases both, shall be installed at the service connection or within the following facilities, unless in the judgment of the water department, no hazard exists: hospitals, mortuaries, clinics, laboratories, sewage treatment plants, food and beverage processing plants, chemical plants using water processing, metal plating industries, petroleum processing or

storage plants, car washes, facilities having a nonpotable auxiliary water supply, and others specified by the water department. (Ord. 913 § 1, 2001; Ord. 788B § 1:04, 1994)

### **13.10.050 Installation requirements.**

A. All installed RPBA's, RPDA's, DCDA's, and PVBA's shall be models included on the current list of backflow assemblies, approved for installation in Washington State, and maintained and published by the department. Backflow prevention assemblies in operation but not currently listed shall remain in service provided the backflow prevention assemblies:

1. Were listed on the current Washington State approved cross connection control assembly list at time of installation;

2. Are properly maintained;

3. Are of a type appropriate for the degree of hazard;

4. Are tested and successfully pass the test annually. When unlisted assemblies are moved or require more than minimum maintenance, the unlisted assemblies shall be replaced by an assembly listed on the current approved model list.

B. All air gap and backflow prevention assemblies shall be installed in accordance with the cross connection control manual referenced under WAC 246-290-490.

1. No part of the backflow prevention device shall be submerged in water or installed in a location subject to flooding. If installed in a vault or basement, adequate drainage shall be provided;

2. Devices must be installed at the point of delivery of the water supply, before any branch in the line, or property located just inside the property line. Alternate locations must be approved in writing by the Okanogan public works superintendent prior to installation;

3. The device must be protected from freezing and severe weather conditions;

4. All backflow prevention assemblies shall be of a type and model approved by the Washington State Department of Health and the city of Okanogan;

5. The device shall be readily accessible with adequate room for maintenance and testing;

6. The property owner assumes all responsibility for all maintenance and annual testing of the device.

7. If written permission is granted to install the backflow prevention device inside of the building, the device shall be readily accessible during regular working hours of 8:00 a.m. to 5:00 p.m., Monday through Friday. The city may conduct these and other inspections as provided by OMC 13.04.230.

C. The water department may permit the substitution of a properly installed air gap in lieu of an approved backflow prevention assembly. All such air gap substitutions shall be inspected annually by a Washington State certified backflow assembly tester.

D. A Washington State certified backflow assembly tester shall inspect and test all RPBA's, RPDAs, DCVAs, DCDAs, new PVBA installations, and existing PVBA's discovered through routine inspections.

E. Tests and/or inspections shall be conducted:

1. At the time of initial installation; and
2. Annually after initial installation, or more often as needed; and
3. After the assembly is repaired.

F. The assemblies shall be repaired, overhauled, or replaced whenever found to be defective. The water department will require that improperly installed or altered air gaps be replumbed or replaced by an approved RPBA at the city's discretion. Inspection, tests, and repairs will be reported to the Okanogan water department and copies of said reports will be provided as proof of inspections, tests, and repairs.

G. Okanogan water department shall have the right to deny or discontinue water service to any customers failing to cooperate in the installation, maintenance, testing, or inspection of backflow prevention assemblies according to WAC 246-290-100. (Ord. 913 § 2, 2001; Ord. 788B § 1:05, 1994)

### **13.10.060 Access to premises.**

A. Authorized employees of Okanogan, with proper identification, shall have access during reasonable hours to all parts of a premises and within the building to which water is supplied.

B. However, if any water user refuses access to a premises or to the interior of a structure at reasonable times and on reasonable notice for inspection by a cross connection specialist appointed by Okanogan, a reduced pressure principle device will be required to be installed at the service connection at the premises.

C. All backflow prevention devices installed within the service area of the city of Okanogan shall be tested immediately upon installation and annually thereafter by a state certified tester. All such devices found not properly functioning shall be promptly repaired or replaced by the water user. If any such device is not promptly repaired or replaced the city may deny or discontinue water use to the premises. All testing and repairs are the financial responsibility of the water user. (Ord. 913 § 3, 2001; Ord. 788B § 1:06, 1994)

### **13.10.070 Variances.**

Any variances from these requirements shall be requested in writing by the owner and approved by Okanogan prior to device installation. (Ord. 788B § 1:07, 1994)

### **13.10.080 Costs of compliance.**

All costs associated with purchase, installation, inspections, testing, replacement, maintenance, parts, and repairs of the backflow device are the financial responsibility of the water user. (Ord. 788B § 1:08, 1994)

### **13.10.090 Termination of service.**

A. Failure on the part of any customer to discontinue the use of all cross connections is sufficient cause for the immediate discontinuance of public water service to the premises. (WAC 246-290-490)

## Okanogan Municipal Code

B. Service will not be restored until such conditions or defects are corrected. (Ord. 913 § 4, 2001; Ord. 788B § 1:09, 1994)





Item No.	Location & Description of Potential Cross Section	Inspector's Recommendation

Hazardous Chemicals/Products Used or Stored on Site:			
1. _____	4. _____	7. _____	10. _____
2. _____	5. _____	8. _____	11. _____
3. _____	6. _____	9. _____	12. _____

Sketch of Water Lines & Hazard Locations

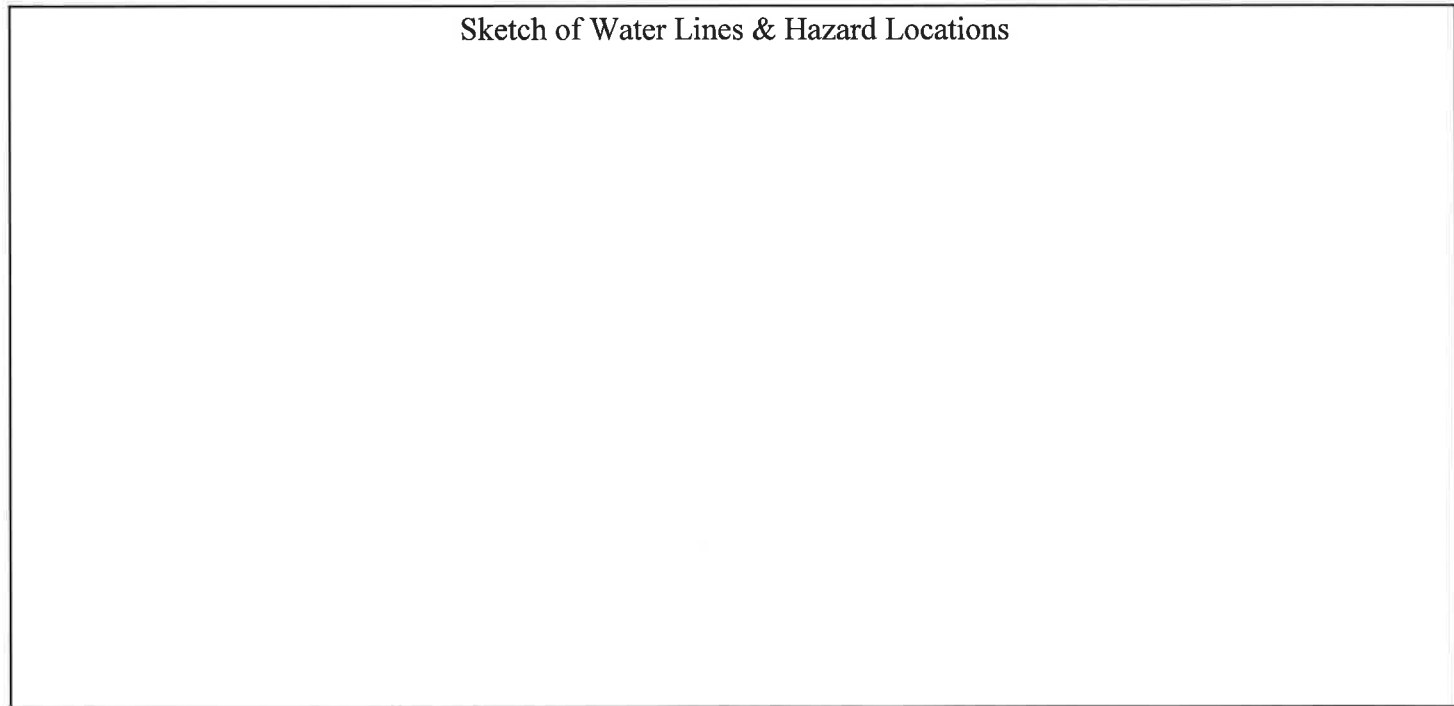

_____ Inspector Signature	_____ Date	_____ Owner Signature	_____ Date
------------------------------	---------------	--------------------------	---------------

## City of Okanogan Cross-Connection Plan Check

Project Name: \_\_\_\_\_ Date \_\_\_\_\_

Project Address: \_\_\_\_\_

Owner's Name: \_\_\_\_\_ Phone \_\_\_\_\_

Plumbing Contractor: \_\_\_\_\_ Phone \_\_\_\_\_

Plans approved as submitted, with the following backflow protection devices installed as indicated:

Device	Location & Hazard	Size

Plans approved provided the following conditions are met:

Items	Recommended Correction

\_\_\_\_\_  
Inspected by:

Based upon a review of the above information and the *Cross Connection Control Program Survey* completed by the owner, premise isolating backflow prevention assemblies shall be installed on the following service connections:

Device Type	Type of Service	Size

\_\_\_\_\_  
Building Official or Authorized Designate

## *Tester List*

<i>Tester</i>	<i>Address</i>	<i>Phone</i>	<i>Cell/Pager</i>
Chad Linklader	186 Omak Mountain Rd, Omak, WA 98841	(509) 826-6383	322-1715
Charles Kauffman	PO BOX FF, Tonasket, WA 98855	826-0660	
McDaniel, Brian	604 Ski View Drive, East Wenatchee, WA 98802	(509) 886-5092	(509) 679-3264
Moshe Levine	PO Box FF, 224 W 4th AV, Tonasket, WA 98855	(509) 486-2446	
Richard Schubert	, 1113 N. 6th AV, Yakima, WA 98902-1468	1-800-473-4034	(509) 728-3229
Scott Heston	230 Grant Road, Suite 3A, Wenatchee, WA 98802	(509) 886-3473	(509) 969-8738

## Customer List by Account #

Account	Customer Name	Make	Model	Serial	Size	Type	Assembly Location
101	Okanogan County Maintenance	AMES	2000BM3	30618	.75	DCVA	jail, evidence/storage room
		AMES	300GV	NG-0964	4	DCVA	fire sprinkler main
		HRSY GRNL	FRP2	94660	1.5	RPBA	jail booking room
		WILKINS	950XL	1132575	1	DCVA	garage/mechanical rm, so entrance
		WILKINS	975XL	2709174	.75	RPDA	Court House, Boiler Room
		WILKINS	975XL	3010723	1	RPBA	Court House, boiler/mechanical rm
		WILKINS	975XL	W238006	2	RPBA	Juvenile Hall, mechanical room
102	Okanogan School District	AMES	200	GI-1384	2.5	DCVA	1118 S. 5th
		AMES	200	GJ-2882	2.5	DCVA	244 S. 5th
		AMES	200	HD-1251	4	DCVA	246 S. 5th
		AMES	200	HI-2012	2.5	DCVA	244 S. 5th
		FEBCO	825Y	AD8015	1.5	RPBA	EI S, mechanial closet, Rm 602
		WATTS	009 QT	43892	.75	RPBA	VG S, boiler room
		WATTS	009MZ	A30405	2	RPDA	Music Mezzanine Fire Riser
		WATTS	800M4 QT	006195	2	PVBA	HS, football field
		WILKINS	350	J24831	3	DCVA	Dawson Hall, room541
		WILKINS	350A	U08469	4	DCVA	JS, Rm 509, fire riser room
		WILKINS	375	L66589	2.5	RPBA	HS, boiler Room
		WILKINS	950XL	2731655	2	DCVA	North ball field, vault
		WILKINS	950XLT	2640381	2	DCVA	HS, woodshop, mezanine attic
		WILKINS	975XL	1279729	2	RPBA	EI S, south ball field
		WILKINS	975XL	2580570	1.25	RPBA	MS, room 509, mezzanine
		WILKINS	975xl	316252xltcu	.75	RPBA	HS, woodshop, mezanine - attic
103	Okanogan, City of	FEBCO	825Y	A9290	2	RPBA	East Side Liftstation, 95 East Oak
		FEBCO	850	N070713071	4	DCVA	Progressive Flats Master Meter Pit, 142 Conconully Hwy
		WATTS	007-M1 QT	1081040	2	DCVA	Cemetery Rd, in pump house building
		WILKINS	720-A	T047220	1	PVBA	on south wall outside Fire Dept.
		WILKINS	950 XLT	3529607	1	DCVA	Arbordium Park
		WILKINS	950 XLT	3629647	1	DCVA	Legion Park South
		WILKINS	950 XLT	3804191	.75	DCVA	Senior Center
		WILKINS	950 XLT	3804194	.75	DCVA	Timm Park
		WILKINS	950 XLT	3804201	.75	DCVA	J.C. Park north
		WILKINS	950 XII	3804221	.75	DCVA	J.C. Park south
		WILKINS	950 XLT	3804223	.75	DCVA	Oak St. Bridge sign
		WILKINS	950 XLT	3823528	2	DCVA	Alma Park
		WILKINS	950 XLT	3823530	2	DCVA	Legion Park North
		WILKINS	950 XLT	3829639	1	DCVA	Sass Fenno Park
		WILKINS	950XL	3882836	.75	RPBA	elec. Room/ lab
		WILKINS	950XL	785063	2	DCVA	Sports Complex, by well, Rodeo Trail Road
		WILKINS	950XLT	2795889	2	DCVA	City Public Works Shop (hydrant use) 7-31-07, 1601 1st AV S
		WILKINS	950XLT	2910762	.75	DCDA	State Patrol Park
		WILKINS	950XLT	3405291	1.5	DCVA	Boat Launch Park, Tyee St & River AV
		WILKINS	950XLT	3482916	2	DCVA	Vin Mar Rd, in pit, by master meter
WILKINS	975XL	750243	2	RPBA	Treatment Plant, blower room, 1610 1st AV S		
WILKINS	975XL	W228334	1.5	RPBA	Elmway Sewer Lift Station, 2018 Elmway		
WILKINS	975XL	W233334	.75	RPBA	City Hall, boiler room, 120 3rd AV N		
104	Youngstrom Properties	FEBCO	805Y	57774	1	DCVA	Mech Room
105	Ross Oil Company	WATTS	575	84438	1.5	RPBA	Food Depot Bld, 310 2nd AV S, SW corner of storage area. 1.5"
106	Okanogan County PUD No 1	FEBCO	825Y	R5729	.75	RPBA	Mechanic Shop, 1331 2Nd AV N
		WILKINS	950XLT	3251925	2	DCVA	NE corner of office building, green irrigation box
		WILKINS	975XL	W366772	.50	RPBA	Mechanical Room
107	Community Action	AMES	2000SS	21M1419	4	DCVA	Back room
109	US Postal Service	WILKINS	975XL	3540417	1	RPBA	in basement by boiler
		WILKINS	975XL	783609	.75	RPBA	Basement, boiler room
110	State of WA Military Dept.	FEBCO	825Y	W1483	.75	RPBA	Okagonan Armory, boiler room, located in the southwest room of building

## Customer List by Account #

Account	Customer Name	Make	Model	Serial	Size	Type	Assembly Location
111	Nau, Robert N. D.D.S.	WILKINS	950XL	1276252	.75	DCVA	Vault, southwest side of building.
112	American Produce Express LLC	WILKINS	975XL	1517917	1.5	RPBA	In janitor's closet in basement
113	Rubert, Allen and Mary	WILKINS		A148279	1	DCVA	S.E. Corner of house
114	Family Health Centers	FEBCO	825Y	J047328	1	RPBA	626 2nd ave S.
		WILKINS	975XL	W112695	1.5	RPBA	Janitor Rm
116	Wilson, Mike	WILKINS	950XLT	2007940	1	DCVA	East side of house.
117	Yusi, Brent	WILKINS	950XLT	1561652	1	DCVA	Basement, next to the hot water tank.
121	Blackbird Clinic	WILKINS	975XL	W245199	.75	RPBA	Basement, boiler room
122	Valley Care Center	AMES	Colt200	GK1054	6	DCDA	Room 14, east hallway
		WATTS	DO7M2QT	A07195	1.5	DCVA	Water Vault, east side of building in lawn area.
		WILKINS	975XL	2466585	1.25	RPBA	North closet for hot water tank.
		WILKINS	975XL	W211786	2	RPBA	Laundry Room.
123	Colville Tribal Casino	WILKINS	550	W90062	3	DCVA	SW corner of Building, in mechanical room
		WILKINS	720A	344717	1.5	PVBA	Northeast corner of lot, next to fire hydrant
		WILKINS	975XL	W048615	2	RPBA	SE corner of maintenance storage room
124	OK Sunshine Cleaners	WILKINS	950XL	B641353	1.5	DCDA	back room East side
126	Burts, Doug & Janet	WILKINS	950XLT	2326639	1.5	DCVA	Paramount Bld, 128 3rd AV S, basement SE corner of building.
127	Blackwell Building - Big Valley Realty	FEBCO	805Y	BA827A	2	DCVA	basement, northend
128	Clean Image Car Wash, WH-2 Investments	WILKINS	950XLT	2639072	2	RPBA	Back of mech room
130	Blue Mountain Hotel	WILKINS	950XLT	3029692	1	DCVA	2nd AV S, by water meter box, in vault
131	Chase, Andy	WILKINS	350XL	h3	1	DCVA	N.W. corner of property 7 ft. east of water meter box
132	Elmwood Apartments-AD West Realty Inc	FEBCO		710-2	2	PVBA	north of south driveway entrance in bushes
133	US Forest Service Bluilding	WATTS	007M2QT	17272	1.25	DCVA	Mechanical Room
		WILKINS	950XLT	3637818	1.5	DCVA	NW corner of building
134	Manning, Richard	WILKINS	950XLT	1605392	.75	DCVA	N.E. corner by shop
135	Attridge, Larry						
136	Budravage, Allen & Teresa	WILKINS	950XLT	3606278	1	DCVA	basement mechanical room
137	OCHS	WILKINS	950XLT	3767964	1	DCVA	in front of office
139	Streeter, Steve	WILKINS	950 XLT	1771080	.75	DCVA	west-irrigation box
141	Rawson's	WILKINS	975XLT	3787921	.75	RPBA	Behind Boiler
142	Clark, Scott	WILKINS	950XLT	3795192	1	DCVA	basement , west wall
202	McGuin, Rashell	WILKINS	950XL	W290651	.75	DCVA	On 2nd AV N, along fence by meter box.
204	Baum, Brett & Lisa	WILKINS	950XLT	1831798	.75	DCVA	Northeast corner of lot by meter box.
205	Okanogan Ice Company	WILKINS	950XLT	1391889	2	DCVA	In basement on north wall.
207	Furman, Scott						
208	Shacklett, Bob	WILKINS	950XLT	3207545	1	DCDA	at water meter
209	Schreckengost, Don	WILKINS	975XL	W235180	.75	RPBA	Basement of house, next to well.
210	Turner, Ken & Vickie	N/A	N/A	Air-Gap	.75	AG	South side of house, underground vault
211	Knox, Jim & Jane	WILKINS	950XLT	2525348	.75	DCVA	near meter box
212	Hill, Cassi	CONBRACO	40105A2T	M2451	1	DCVA	In lawn, northwest corner of house in vault
213	Moomaw, Doug			00000	.75	AVB	outside water tap
214	Davis, Keith	WILKINS	950XL	3463270	.75	DCVA	downstairs bathroom
215	Garrison, Bob	WILKINS	950XLT	2463223	1	DCVA	front yard @ meter base
216	Heddington, Homer	WILKINS	950 XLT	3748295	1	DCVA	pit in North side yard
217	Pfiefer, Joan	WILKINS	950XLT	434209	.75	DCVA	left of driveway
218	Harrison, CJ	WILKINS	720A	A214294	1	PVBA	southwest corner of house
219	Holmdahl, Todd & Anne	WILKINS	950XLT	1697818	.75	DCVA	northeast of property, right of driveway
220	Cotter, Robert	WILKINS	950 XLT	2819981	.75	DCVA	In side garage, back wall



## *Customer List by Account #*

<i>Account</i>	<i>Customer Name</i>	<i>Make</i>	<i>Model</i>	<i>Serial</i>	<i>Size</i>	<i>Type</i>	<i>Assembly Location</i>
221	Bowlin, Richard & Susan			00000000		AG	private well is located in basement of house
222	Shapley, Angie	WILKINS	350XL	197344	1	DCVA	pit, S.E. corner of house
223	Okanogan Garden Apts.	WILKINS	950	1103117	2	DCVA	Conconully St. by meter box
224	Seeger, Dave	WILKINS	950XLT	2312177	.75	DCVA	against house on the west side
228	Spencer, Karen	WILKINS	350	AZ66250	.75	DCVA	west side of house before ramp.
229	Geolz, Brian	WILKINS	950XLT	3748283	1	DCVA	basement
230	Clough, Joe			1111111			south side of house in crawl space
231	Bessire, Scott (accounting)	WILKINS	950 XLT	3979888	1	DCVA	basement
232	Naddy, Lew C/O Beverly Herbst	WILKINS	350 XL	A172864	.75	DCVA	south of south driveway about 12 feet off of sidewalk
233	Church of Crist	WILKINS	950 XL	4018506	1	DCVA	Mechanic room by hot water heater





**CITY OF OKANOGAN WATER SERVICE APPLICATION**

PROPERTY OWNER'S NAME, MAILING ADDRESS & CONTACT PHONE NUMBER				
STREET ADDRESS OF SITE:			PARCEL NUMBER	
SHORT LEGAL DESCRIPTION OF PROPERTY				
INITIAL INSTALLATION OF SERVICE REQUESTED				
METER SIZE: (Please circle one)      ¾"      1"      1½"      2"      Larger?				
<b>REQUESTED PERMIT USE</b>				
TYPE		DESCRIPTION(S)		
RESIDENTIAL DOMESTIC USE:	Yes    No			
COMMERCIAL:	Yes    No			
INDUSTRIAL:	Yes    No			
OTHER:	Yes    No			
<b>HAZARDS &amp; CONTROL</b>				
TYPE		DESCRIPTION(S)		
ALTERNATE WATER SOURCE (examples) Private Well Irrigation District, Other?				
ACTIVITIES (examples) Swimming Pool Spa/Hot Tub Fountain/Pond Sprinkler System Other?				
SPECIALIZED EQUIPMENT (examples) Home Business Photo Studio Tattoo Parlor Kidney Dialysis Other?				
OTHER: (examples) Livestock Kennel				
Existing Utilities (examples) Private and/or Public Water Sewer Storm Drainage Power	None:	On Site:	Public:	Other:

The above answers are true and complete to the best of my knowledge. I understand that the water service purveyor is relying on them to make their decision. Further that said service if granted, is contingent on continued compliance with City of Okanogan ordinances regulating water service, use and related fees.

Signature: \_\_\_\_\_ Date Submitted: \_\_\_\_\_

Public Works Comments: \_\_\_\_\_

FEES: \_\_\_\_\_ (computed by: \_\_\_\_\_) RECEIPT # \_\_\_\_\_

Equivalent Residential Units: \_\_\_\_\_ Hazards Controls Verified by: \_\_\_\_\_

\_\_\_\_\_  
Public Works Director

\_\_\_\_\_  
Date

Description	Date
Fill out Application	
Forward to:	
<i>Water Manager</i>	
<i>Sewer Plant Operator</i>	
<i>Other Public Works</i>	
<i>Building Official</i>	
<i>Fire Chief</i>	
Contact Applicant	
Review Application	
Forward to Clerk's Office	
Determine Fee	
Send Applicant Letter	
Collect Fees	
Forward to Public Works	
Determine Date of Work	
Inspection of Work in Progress	
Inspect Backflow	
Final Approval	
Date Completed	
Distribute for Record Keeping	

**APPENDIX G**

**EMERGENCY RESPONSE PLAN**

## APPENDIX G

### EMERGENCY RESPONSE PLAN

The following section describes means and methods for the City to respond to emergency situations affecting its water utility. It includes a list of important telephone numbers for emergencies, some general considerations that should be kept in mind by City staff during an emergency, and specific emergency response plans.

#### EMERGENCY CONTACTS

**Table G-1  
Emergency Call List**

Person or Agency	Phone Number
<b>City Personnel</b>	
Jon Culp, Mayor	(509) 422-3600 (Office)
Shawn Davisson, Public Works Director	(509) 322-0121 (Cell) (509) 422-2692 (Home)
Loren Howell, Water System Manager	(509) 322-0150 (Cell) (509) 422-0717 (Office)
Craig Atwood, Clerk-Treasurer	(509) 422-3600 (Office)
<b>Local, State, and Federal Agencies</b>	
Fire Department	911 or (509) 422-5757
Washington State Department of Health, Spokane Mike Wilson, P.E., Engineer	(509) 329-2100 (509) 329-2117
Washington State Dept. of Ecology (DOE), Yakima	(509) 575-2490
Department of Health Emergency Hotline	(877) 481-4901
Okanogan County Public Works	(509) 422-7300
Okanogan County Sheriff	(509) 422-7200
Okanogan County Health Department	(509) 422-7140
State Division of Emergency Management	(800) 258-5990
U.S. Environmental Protection Agency	(206) 553-1200
<b>Utilities</b>	
Okanogan County Public Utility District (Emergency Outages)	(509) 422-3310
CenturyTel	(800) 201-4099
One-Call Locates	(800) 424-5555
<b>Suppliers, Contractors</b>	
H.D. Fowler	(509) 547-2410
<b>City Engineer</b>	
Gray & Osborne	(509) 453-4833

## **EMERGENCY PROCEDURES**

Although it is not possible to anticipate all potential disasters affecting the City's water system, formulating procedures to manage and remedy several common emergencies is appropriate.

### **BACTERIOLOGICAL DETECTION**

The persistent detection of coliforms in the water supply, particularly E. coli or fecal bacteria, may require issuing a public boil water notice to ensure the health and safety of the City's water customers. In addition, emergencies such as floods, earthquakes, or other disasters can affect water quality as a result of damage to water system facilities. WAC 246-290-320 requires water utilities to follow specific procedures in the event coliform bacteria are detected in the water system. The City's Coliform Monitoring Plan in Appendix B summarizes increased sampling requirements in the month following coliform detection.

### **FIRES**

The availability of adequate water supplies and pressure is an integral part of the City's ability to fight fires within its service area. When fires occur in the City's service area, the local fire authority will contact the City so that the water system components can be managed in such a way as to maximize the flow and pressure to the affected area.

It is the City's policy that fire hydrants that provide less than 500 gpm discharge are to be painted black to facilitate emergency services via color-coded hydrants.

### **OTHER CONSIDERATIONS**

In addition to water quality notification, some water customers require immediate notification should their water service be interrupted for any reason. These customers include facilities such as nursing homes, elder care facilities, and kidney dialysis patients. It is recommended that the City maintain a list of all these customers so that in the event the City's water supply is to be interrupted because of an emergency situation these customers can be notified.

## **VULNERABILITY ANALYSIS**

Identification of system facilities that may be adversely affected during an emergency situation is important in determining areas where redundant facilities may be needed. Types of emergencies include loss of power, severe weather, flooding, earthquake, major equipment failure, and vandalism.

### **Loss of Power**

The DOH 2009 Water System Design Manual identifies minimum criteria for consideration of the reduced need for alternative power at the source when the power grid

is capable of providing service. These criteria include the occurrence of less than three outages per year in the previous three years and less than six outages in any given year. Also, the duration of the outages must have averaged less than four hours over the previous three years. As stated in Chapter 3, the City’s power source appears to have met these criteria.

**Table G-2  
Power Outage Vulnerability Assessment**

<b>Telemetry</b>	<i>Low Risk</i>	The telemetry system requires electrical power supplied by Okanogan County PUD and communications via the local telephone service provider.
	<i>Prevention</i>	None.
	<i>Mitigation</i>	As the telemetry system is not functional during a power outage, the water levels in the reservoirs must be manually controlled. During a telephone outage, the well pumps must be operated manually depending on the water levels in the reservoirs.
<hr/>		
<b>Source</b>	<i>Low Risk</i>	Power outages have not historically been an issue. The City has sufficient standby storage to supply water during minor outages.
	<i>Prevention</i>	Wells and the booster station could be equipped with manual transfer switches to accept a generator or equipped with alternative power sources.
	<i>Mitigation</i>	City has sufficient standby storage to supply water during minor outages.
<hr/>		
<b>Storage</b>	<i>No Risk</i>	The City’s reservoirs are not vulnerable to power outages.
<hr/>		
<b>Distribution</b>	<i>No Risk</i>	The City’s distribution system is not vulnerable to power outages.

**Severe Weather**

Types of severe weather, which may create problems for the water system, are wind storms, freezing rain, cold temperatures, and snow storms.

**Table G-3  
Severe Weather Vulnerability Assessment**

<b>Telemetry</b>	<i>Moderate Risk</i>	The telephone lines that carry the communications signals for the telemetry system and the power source that powers the telemetry system have a moderate vulnerability to high winds and freezing rain.
	<i>Prevention</i>	Maintain telemetry equipment.
	<i>Mitigation</i>	Manual operation of the system may be needed to mitigate the effects of severe weather. Report telephone line and power outages immediately to utility companies when system is impacted.
<hr/>		
<b>Source</b>	<i>No Risk</i>	The City's sources are not susceptible to severe weather.
<hr/>		
<b>Storage</b>	<i>Moderate Risk</i>	Extreme cold weather could cause ice formations on the water level sensors inhibiting telemetry.
	<i>Prevention</i>	During extreme cold weather, check sensors and clean them temporarily if ice formation is a concern.
	<i>Mitigation</i>	Run system manually if sensors freeze. If necessary, use the other reservoir while repairs are made.
<hr/>		
<b>Distribution</b>	<i>No Risk</i>	The City's distribution system is not vulnerable to severe weather.

**Earthquake**

An earthquake could damage water system components and infrastructure. The City's service area is located in the Uniform Building Code Seismic Zone 2B. This zone contains a moderately low risk to earthquakes.



**Table G-4  
Earthquake Vulnerability Assessment**

<b>Telemetry</b>	<i>Low Risk</i>	There is a low risk of structural failure.
	<i>Prevention</i>	Perform emergency planning.
	<i>Mitigation</i>	Rely on manual operation of system components until the system can be repaired.
<b>Source</b>	<i>Low Risk</i>	There is a low risk that structural failure and aquifer shift would cause failure of all of the City's wells.
	<i>Prevention</i>	Perform emergency planning.
	<i>Mitigation</i>	Rely on other wells or provide trucked in water until the City's wells can be repaired, or new wells can be drilled.
<b>Storage</b>	<i>Low Risk</i>	There is a low risk of structural failure during an earthquake. The transmission main connecting to the reservoirs may be at risk.
	<i>Prevention</i>	Perform emergency planning. Prepare a plan to operate the system as a closed system.
	<i>Mitigation</i>	Rely on remaining reservoirs. Provide trucked in water until additional storage can be constructed or closed system can be set up.
<b>Distribution</b>	<i>Low Risk</i>	The distribution system is at low risk for failure that would result in leaks and possible contamination.
	<i>Prevention</i>	Perform emergency planning. Install valves for main isolation.
	<i>Mitigation</i>	Depending on the severity of the damage, provide trucked in water until repairs can be made.

**Vandalism**

Vandalism is a concern because the quality of the water supply as well as the facility operation may be affected.

**Table G-5  
Vandalism Vulnerability Assessment**

<b>Telemetry</b>	<i>Low Risk</i>	The telemetry equipment is mostly enclosed in buildings and considered to be safe. A portion of the telemetry system located at the West Reservoirs is somewhat susceptible to vandalism.
	<i>Prevention</i>	The City checks facilities frequently to see that access is secure.
	<i>Mitigation</i>	Operate disabled components manually until repairs can be made.
<hr/>		
<b>Source</b>	<i>Low Risk</i>	There is a low risk of damage to the wells. All wells are located in locked well houses or are behind fences.
	<i>Prevention</i>	The City checks facilities daily to see that access is secure.
	<i>Mitigation</i>	Use alternative sources until repairs are made and testing indicates water is potable.
<hr/>		
<b>Storage</b>	<i>Low Risk</i>	The City has historically not had problems with exterior tank vandalism. The City restricts access to the roof of the reservoirs with difficult to reach ladders, locked hatches, and screened vents.
	<i>Prevention</i>	Consider fencing the reservoir sites to restrict site access.
	<i>Mitigation</i>	If a reservoir is suspected of contamination, isolate, drain and clean according to AWWA guidelines.
<hr/>		
<b>Distribution</b>	<i>Low Risk</i>	The distribution system is at low risk for failure that would result in leaks and possible contamination.
	<i>Prevention</i>	Perform emergency planning. Install valves for main isolation.
	<i>Mitigation</i>	Depending on the severity of the damage, provide trucked in water until repairs can be made.



## OKANOGAN FIRE DEPARTMENT

July 31, 2007

### Fire Flow Requirements for Large Structures.

1. Food Depot, 310 2<sup>nd</sup> Ave. South, 27,750sqft. Fully Sprinkled 1500gpm 2 hours
2. Cedars Inn, 1 Appleway, 6,000sqft. 2000gpm for 2 hrs.
3. Okanogan Jr. Sr. High School/Middle School 244 5<sup>th</sup> Ave. South, 47,402sqft, 1500gpm for 2 hrs. Building is fully sprinkled.
4. Virginia Grainger Elementary 1118 5<sup>th</sup> Ave. South, 7746sqft, 1,750gpm for 2 hrs.(2800sqft addition sprinkled.)
5. Okanogan School District #105, 334 5<sup>th</sup> Ave. South, Vo Ag building 10,566sqft. 1500gpm for 2hrs, sprinkled.
6. Okanogan School District #105, 424 5<sup>th</sup> Ave. South, Dawson Gym 13,650sqft 1500gpm for 2hrs, sprinkled.
7. Okanogan County Office, 123, 5<sup>th</sup> Ave. North, 12,000sqft, 3,000gpm for 3 hrs.
8. Rawson=s Department Store 212 2<sup>nd</sup> Ave. South 18,000sqft 3,750gpm for 3 hrs.
9. Magi Inc. 124 Van Duyn, 37,500sqft, 5,250gpm for 4 hrs,
10. Magi Inc. 124 Van Duyn, 11,904sqft, 3,000gpm for 3 hrs.
11. Magi Inc. 124 Van Duyn, 4,641sqft, 1,750gpm for 2 hrs.
12. Magi Inc. 124 Van Duyn, 7,500sqft, 2,250gpm for 2 hrs
13. Magi Inc. 124 Van Duyn, 15,000sqft, 3,250gpm for 3 hrs.
14. Okanogan County Courthouse, 149, 3<sup>rd</sup> North, ~~56,400sqft~~ <sup>33,467 sq. ft.</sup> ~~6,500gpm~~ <sup>\*</sup> for 4 hrs.
15. Okanogan County Jail, 149 3<sup>rd</sup> Ave. North 30,000sqft. 1,750gpm for 2hrs Sprinkled. <sup>5,000gpm</sup>
16. Okanogan Bingo Casino, 7 Appleway, 16,200sqft, Sprinkled 1500gpm for 2 hrs.
17. Ringhoffer building , Forest Service, 1240 , 2<sup>nd</sup> Ave. South, 15,000sqft, 3,000gpm for 3hrs.

\* REVISED TO 5,000 gpm per email Oct. 7, 2015



## OKANOGAN FIRE DEPARTMENT

18. Okanogan County Public works, 1234, 2<sup>nd</sup> Ave South, 22,800sqft, 4,000gpm for 4hrs.
19. Okanogan Senior Center, 1300, 2<sup>nd</sup> Ave South, 6,000sqft, 2,000gpm for 2hrs.

## Dave Ellis

---

**From:** Shawn Davisson <okanogandpw@gmail.com> on behalf of Shawn Davisson <okanogandpw@ncidata.com>  
**Sent:** Tuesday, October 13, 2015 12:58 PM  
**To:** Dave Ellis  
**Subject:** FW: Courthouse Fire Flow

Dave:

The first paragraph in the 2<sup>nd</sup> email below is the building we need in the comp plan. Please contact me should you have any questions. Also, call me when you have a minute.

Shawn Davisson  
Public Works Director  
City of Okanogan

---

**From:** Jerod Gavin [<mailto:fire41@northcascades.net>]  
**Sent:** Tuesday, October 13, 2015 10:48 AM  
**To:** [bdokanogan@ncidata.com](mailto:bdokanogan@ncidata.com); [okanogandpw@ncidata.com](mailto:okanogandpw@ncidata.com)  
**Subject:** RE: Courthouse Fire Flow

Christian,

Your numbers sound fine to me. More than adequate for extinguishment. I do not foresee needing to sustain a fire flow of 1500 GPM for 12 hrs continuously and find it a lot a bit overboard.

Jerod

---

**From:** Christian Johnson (OK) [<mailto:bdokanogan@ncidata.com>]  
**Sent:** Tuesday, October 13, 2015 09:57  
**To:** [okanogandpw@ncidata.com](mailto:okanogandpw@ncidata.com); 'Jerod Gavin'  
**Subject:** RE: Courthouse Fire Flow

Shawn,  
Bldg "A" 124 Van Dayn Street (first building on the right) is a controlled atmosphere, dry storage and shipping building that has a floor area (fire area) of 69,807 sq ft and is 3B construction; based on that square footage and type of construction we should have 5,500 gpm for 4 hrs @ 20 psi residual for tabled protection.

The Pear Palace is a vacant derelict building (the Assessor's Office has it as a cost to cure); our standing plan is to conduct a hasty search to ensure the building is vacant and then protect the exposure to the other buildings around it and not attempt a save. Per B103.1 IFC the fire flow needed for this plan is 1,500 gpm for 12 hrs

I will confer with Jerod if he wishes to revise Gordon's SOP.  
Christian

---

**From:** Shawn Davisson [<mailto:okanogandpw@gmail.com>] **On Behalf Of** Shawn Davisson  
**Sent:** Thursday, October 08, 2015 1:25 PM  
**To:** Johnson, Christian; Jerod Gavin  
**Subject:** FW: Courthouse Fire Flow

Christian:

What are your thoughts to Dave's email, below?

Shawn Davisson  
Public Works Director  
City of Okanogan

---

**From:** Dave Ellis [<mailto:dellis@g-o.com>]  
**Sent:** Thursday, October 08, 2015 1:14 PM  
**To:** [okanogandpw@ncidata.com](mailto:okanogandpw@ncidata.com)  
**Subject:** RE: Courthouse Fire Flow

So it appears that the courthouse does not have the largest fire flow requirement...that belongs to Magi Inc. (5,250 gpm for 4 hours). Does that sound correct?

*David Ellis, P.E.*



*107 South Third Street, Yakima, WA 98901  
Phone: (509) 453-4833 Fax: (509) 453-5953*

---

**From:** Shawn Davisson [<mailto:okanogandpw@gmail.com>] **On Behalf Of** Shawn Davisson  
**Sent:** Thursday, October 08, 2015 12:22 PM  
**To:** 'Dave Ellis'  
**Cc:** Attwood, Craig; [okanoganmayor@northcascades.net](mailto:okanoganmayor@northcascades.net); Johnson, Christian; Jerod Gavin; 'Chris Johnson'; Loren Howell  
**Subject:** RE: Courthouse Fire Flow

Dave:

I'm having a meeting with Chief Gavin right this minute, he agrees with Building Official Johnson's analysis below.

Shawn Davisson  
Public Works Director  
City of Okanogan

---

**From:** Dave Ellis [<mailto:dellis@g-o.com>]  
**Sent:** Thursday, October 08, 2015 12:08 PM  
**To:** 'Shawn Davisson'  
**Subject:** RE: Courthouse Fire Flow

Let me know if the fire chief agrees and I'll recalculate the fire flow storage requirements.

*David Ellis, P.E.*



107 South Third Street, Yakima, WA 98901  
Phone: (509) 453-4833 Fax: (509) 453-5953

---

**From:** Shawn Davisson [<mailto:okanogandpw@gmail.com>]  
**Sent:** Wednesday, October 07, 2015 2:40 PM  
**To:** Dave Ellis  
**Cc:** Loren Howell  
**Subject:** Fwd: Courthouse Fire Flow

Sent from my iPhone

Begin forwarded message:

**From:** "Christian Johnson (Oka)" <[bdokanogan@ncidata.com](mailto:bdokanogan@ncidata.com)>  
**Date:** October 7, 2015 at 2:14:48 PM PDT  
**To:** Shawn Davisson <[okanogandpw@ncidata.com](mailto:okanogandpw@ncidata.com)>, Okanogan Fire Chief  
<[fire41@northcascades.net](mailto:fire41@northcascades.net)>  
**Subject:** Courthouse Fire Flow

Shawn,

After re-visiting the issue; I have determined that the largest un-separate floor area of the Courthouse (the jail is a separate building via a an area separation wall) to be 33,467 sq ft. Table B105.1 IFC '12 provides that such buildings should be protected with not less than 5,000 gallons per minute measured at 20 psi residual for a period of not less than 4 hours.

It is my impression that the previous calculation were using the building(s) as a whole and not excluding the exterior walls as allowed by code.

I will discuss the matter with Chief Gavin this evening.  
Christian



**APPENDIX H**

**CONSISTENCY STATEMENTS**



## Local Government Consistency Review Checklist

Water System Name: City of Okanogan Water System PWS ID: 63200M

Planning/Engineering Document Title: Water System Plan Plan Date: January 2016

Local Government with Jurisdiction: City of Okanogan Planning

**WAC 246-290-108 Consistency with local plans and regulations:**

Consistency with local plans and regulations applies to planning and engineering documents under WAC 246-290-106, 246-290-107, and 246-290-110(4)(b) (ii).

1) Municipal water suppliers must include a consistency review and supporting documentation in its planning or engineering document describing how it has addressed consistency with **local plans and regulations**. This review must include specific elements of local plans and regulations, as they reasonably relate to water service as determined by Department of Health (DOH). Complete the table below and see instructions on back.

Local Government Consistency Statement	Page(s) in Planning Document	Yes – No – Not Applicable
a) The water system service area is consistent with the adopted <u>land use and zoning</u> within the applicable service area.	Fig. 1-3	YES
b) The <u>six-year growth projection</u> used to forecast water demand is consistent with the adopted city/county's population growth projections. If a different growth projection is used, provide an explanation of the alternative growth projection and methodology.	2-10	YES
c) Applies to <u>cities and towns that provide water service</u> : All water service area policies of the city or town are consistent with the <u>utility service extension ordinances</u> of the city or town.	1-13	YES
d) <u>Service area policies</u> for new service connections are consistent with the adopted local plans and adopted development regulations of all jurisdictions with authority over the service area [City(ies), County(ies)].	1-13	YES
e) Other relevant elements related to water supply are addressed in the water system plan, if applicable; Coordinated Water System plans, Regional Wastewater plans, Reclaimed Water plans, Groundwater Area Management plans, and Capital Facilities Element of Comprehensive plans.		YES

I certify that the above statements are true to the best of my knowledge and that these specific elements are consistent with adopted local plans and development regulations.

Signature

CHUCK JOHNSON, PLANNER CITY OF OKANOGAN

Date

3/9/2016

Printed Name, Title, & Jurisdiction





## Local Government Consistency Review Checklist

Water System Name: City of Okanogan Water System PWS ID: 63200M

Planning/Engineering Document Title: Water System Plan Plan Date: January 2016

Local Government with Jurisdiction: Planning Department of the Confederated Tribes of the Colville Reservation

**WAC 246-290-108 Consistency with local plans and regulations:**

Consistency with local plans and regulations applies to planning and engineering documents under WAC 246-290-106, 246-290-107, and 246-290-110(4)(b) (ii).

1) Municipal water suppliers must include a consistency review and supporting documentation in its planning or engineering document describing how it has addressed consistency with **local plans and regulations**. This review must include specific elements of local plans and regulations, as they reasonably relate to water service as determined by Department of Health (DOH). Complete the table below and see instructions on back.

Local Government Consistency Statement	Page(s) in Planning Document	Yes - No - Not Applicable
a) The water system service area is consistent with the adopted <u>land use and zoning</u> within the applicable service area.	Fig. 1-3	YES
b) The <u>six-year growth projection</u> used to forecast water demand is consistent with the adopted city/county's population growth projections. If a different growth projection is used, provide an explanation of the alternative growth projection and methodology.	2-10	YES
c) Applies to <u>cities and towns that provide water service</u> : All water service area policies of the city or town are consistent with the <u>utility service extension ordinances</u> of the city or town.	1-13	YES
d) <u>Service area policies</u> for new service connections are consistent with the adopted local plans and adopted development regulations of all jurisdictions with authority over the service area [City(ies), County(ies)].	1-13	YES
e) <u>Other relevant elements</u> related to water supply are addressed in the water system plan, if applicable; Coordinated Water System plans, Regional Wastewater plans, Reclaimed Water plans, Groundwater Area Management plans, and Capital Facilities Element of Comprehensive plans.		

I certify that the above statements are true to the best of my knowledge and that these specific elements are consistent with adopted local plans and development regulations.

Pete Palmer  
Signature

3/7/16  
Date

PETE PALMER, LAND USE SHORELINES ADMINISTRATOR  
Printed Name, Title, & Jurisdiction COLVILLE CONFEDERATED TRIBES



## Local Government Consistency Review Checklist

Water System Name: City of Okanogan Water System PWS ID: 63200M

Planning/Engineering Document Title: Water System Plan Plan Date: January 2016

Local Government with Jurisdiction: Okanogan County Planning

**WAC 246-290-108 Consistency with local plans and regulations:**

Consistency with local plans and regulations applies to planning and engineering documents under WAC 246-290-106, 246-290-107, and 246-290-110(4)(b) (ii).

1) Municipal water suppliers must include a consistency review and supporting documentation in its planning or engineering document describing how it has addressed consistency with **local plans and regulations**. This review must include specific elements of local plans and regulations, as they reasonably relate to water service as determined by Department of Health (DOH). Complete the table below and see instructions on back.

Local Government Consistency Statement	Page(s) In Planning Document	Yes - No - Not Applicable
a) The water system service area is consistent with the adopted <u>land use and zoning</u> within the applicable service area.	Fig. 1-3	Yes
b) The <u>six-year growth projection</u> used to forecast water demand is consistent with the adopted city/county's population growth projections. If a different growth projection is used, provide an explanation of the alternative growth projection and methodology.	2-10	Yes
c) Applies to <u>cities and towns that provide water service</u> : All water service area policies of the city or town are consistent with the <u>utility service extension ordinances</u> of the city or town.	1-13	Yes
d) <u>Service area policies</u> for new service connections are consistent with the adopted local plans and adopted development regulations of all jurisdictions with authority over the service area [City(ies), County(ies)].	1-13	Yes
e) <u>Other relevant elements</u> related to water supply are addressed in the water system plan, if applicable; Coordinated Water System plans, Regional Wastewater plans, Reclaimed Water plans, Groundwater Area Management plans, and Capital Facilities Element of Comprehensive plans.		N/A

I certify that the above statements are true to the best of my knowledge and that these specific elements are consistent with adopted local plans and development regulations.

Perry D. Huston  
Signature

2-9-16  
Date

Perry D. Huston, Director of Planning & Development,  
Printed Name, Title, & Jurisdiction for Okanogan County

**APPENDIX I**  
**SEPA CHECKLIST**



# CITY OF OKANOGAN

JON CULP, MAYOR



## Notice of Initiation of Plan Update, Adoption for Implementation and Issuance of a DNS under SEPA

Okanogan 2015 Water System Plan Update

Official Date of Notice: January 20, 2016

**NOTICE IS HEREBY GIVEN THAT** the City of Okanogan, Washington has initiated an update which includes revisions to the City's Water System Plan. A draft plan has been prepared and the City intends to adopt the updated plan. The City will seek approval of the plan by the Washington State Department of Health and the concurrence of operations from the Confederated Tribes of the Colville Indian Reservation. Department of Ecology and the Confederated Tribes of the Colville Indian Reservation will be required to review the City's water rights and make decisions prior to approval of the Plan. Right of way permits will be required for any work within the Washington State Department of Transportation, Okanogan County and/or Bureau of Indian Affairs rights-of-way. Construction approvals such as critical area authorization, general stormwater construction, entry, and shoreline, floodplain, building and electrical permits will be secured prior to the start of each of the specific work listed below (see the Checklist for a narrative of each of the items).

**PROJECT DESCRIPTION:** The Plan is organized into the following chapters: Description of Water System, Basic Planning Data, Water System Analysis, Water Use Efficiency, Source Water Protection, Operation and Maintenance, Construction Standards, Capital Improvement Program, and Capital Improvement Financing.

Chapter 8 – Capital Improvement Program provides a description of the City's proposed 6- and 20-year water system capital improvements. Specifically:

**WATER RIGHTS** - The City plans to file change applications with the Washington State Department of Ecology to consolidate its existing water rights to give the City greater flexibility in managing its water resources.

**AGREEMENTS** - The City plans to review its agreement for the delivery of water for domestic use to the Progressive Flats Water Association.

**SOURCE IMPROVEMENTS** - The City has identified the following source improvements for its 6- and 20-year improvement schedule:

1. Watercress Springs Feasibility Study.
2. Well Improvements.
3. Well No. 3 Inspection.
4. Murray Street Master Meter.
5. Murray Street Booster Pump Station.
6. Well No. 4 Bypass.
7. Well No. 6 (Riverwalk Well).

**STORAGE** - The City has identified the following storage-related improvements for its 20-year improvement schedule:

8. Murray Reservoir.
9. West Reservoirs Improvements.
10. East Reservoir Improvements.

**TREATMENT** - The City has identified the following treatment improvements for its 6- and 20-year improvement schedule:

11. Arsenic Treatment Facility Feasibility Study.
12. Arsenic Treatment Facility Improvements.
13. Well Chlorination Improvements.

**TELEMETRY** - The City has identified the following telemetry system improvements for its 6-year improvement schedule:

14. Telemetry System Improvements.



DISTRIBUTION - The City has identified the following distribution system improvements for its 6- and 20 year improvement schedule:

15. 5th Avenue Water Main. 16. Elmway Water Main Extension (Phase 3). 17. 1st Avenue Water Main. 18. South Okanogan Water System Improvements. 19. Rodeo Trail Water Main Replacement. 20. Highland Drive Water Main Replacement. 21. Tacoma Street/Spokane Street Water Main Loop. 22. 2nd Avenue South Water Main Replacement. 23. Viewmont Drive Water Main Replacement. 24. 3rd Avenue North Water Main Replacement. 25. Mill Street Water System Improvements. 26. Airport Booster Pump Station. 27. 2nd Avenue Water System Improvements.

PROJECT LOCATION: This plan if adopted will be applied to all lands public and private within the Service Area Boundary (UGA-2) of the City of Okanogan, Washington primarily located in Sections 2, 3, 4, 5, 6, 8, 9, 10, 11, 15, 16, 17, 18, 19, 20 and 21 of Township 33 N., Range 26 E WM. and a portion of Section 33 of Township 34 N., Range 26 E.WM., Okanogan County, Washington. Each of the project locations generally coincide with their name. See related maps for specifics.

SEPA: The lead agency for this proposal, which is the City of Okanogan Building & Permits Department, has determined that the proposal does not have a probable significant adverse impact on the environment. An environmental impact statement (EIS) is not required under RCW 3.21C.030(2)(c). This decision was made after review of a completed environmental checklist and other information on file with the lead agency. This determination of non-significance (DNS) is issued under 197-11-340(2); the lead agency will not act on this proposal before February 3, 2016.

HEARINGS: Prior to adoption the City Council will conduct at least one open record public hearing to take relevant testimony from the public, the date and time of this hearing is yet to be scheduled.

Persons desiring to provide written SEPA comments on the proposal must file said comments at the Clerk's Office no later than 4:00 p.m. February 3, 2016. Persons desiring a copy of the decision once made or party of record status must file said request at the Clerk's Office no later than 4:00 p.m. the date of the hearing or at the hearing.

MORE INFORMATION: The complete project file consisting of maps, current proposed draft plan, SEPA Checklist, and Staff Report (when available) are available on the city's web site at [www.okanogancity.com](http://www.okanogancity.com) and follow the links for Public Notices. Copies are also available to the public for inspection and/or purchase, please contact the Clerk's Office, City Hall, (509) 422-3600 during normal business hours. For further information please contact the responsible official below.

Christian D. Johnson, C.B.O., Building Official \* Permit Administrator (509) 422-3600  
P.O. Box 752, Okanogan, WA 98840 e-mail: [bdokanogan@ncidata.com](mailto:bdokanogan@ncidata.com)

Issued: January 12, 2016

Signature:

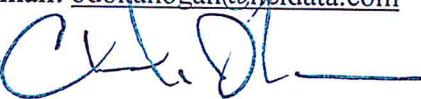

APPEALS: This notice is given pursuant to Section 18.100.050 OMC, appeals under SEPA shall be processed under Chapter 16.08.220 OMC and appeals of the final decision on these applications may be filed by a party of record with standing in Okanogan County Superior Court within 21 days of issuance of the decision as provided by Chapter 36.70C RCW.



SEPA Environmental checklist (WAC 197-11-960)

**A. BACKGROUND**

1. *Name of proposed project, if applicable:*

**Okanogan 2015 Water System Plan Update**

2. *Name of applicant:*

**City of Okanogan, Washington**

3. *Address and phone number of applicant and contact person:*

**Post Office Box 752**

**Okanogan, Washington 98840**

**Shawn Davison, Public Works Director (509)422-3600 okanogandpw@ncidata.com**

4. *Date checklist prepared:*

**This checklist was finalized in December 2015 as a culmination of the review process.**

5. *Agency requesting checklist:*

**City of Okanogan Building & Permits Department**

6. *Proposed timing or schedule (including phasing, if applicable):*

**The Water System Plan update is in the process of review and approval by the City. Projects in this plan are prioritized, for confirmation by the City; the projects will be constructed as funding becomes available through various financing methods and grants.**

7. *Do you have any plans for future additions, expansion, or further activity related to or connected with this proposal? If yes, explain.*

**During the normal course of business, the Water System Plan will be updated in the future. Future plan updates may identify additional water system needs that are not identified in the present plan..**

8. *List any environmental information you know about that has been prepared, or will be prepared, directly related to this proposal.*

**In addition to this SEPA Checklist and checklists prepared for previously adopted versions of the plan; site project/specific reports will be prepared for individual projects where there is the presence of cultural resources and critical areas.**

9. *Do you know whether applications are pending for governmental approvals of other proposals directly affecting the property covered by your proposal? If yes, explain.*

**Not applicable.**

10. *List any government approvals or permits that will be needed for your proposal, if known.*

**Approval of the Water System Plan by the Washington State Department of Health will be needed. In addition the City will seek the concurrence of operations from the appropriate departments/programs of the Confederated Tribes of the Colville Indian Reservation.**

**Department of Ecology and the Confederated Tribes of the Colville Indian Reservation will be required to review the City's water rights and make a decision prior to approval of the Plan.**

**Routine right of way permits will be required for any work within the Washington State Department of Transportation, Okanogan County and/or Bureau of Indian Affairs rights-of-way. Construction permits such as critical area authorization, general stormwater construction, entry, and shoreline, floodplain, building and electrical may be needed.**

11. *Give brief, complete description of your proposal, including the proposed uses and the size of the project and site. There are several questions later in this checklist that ask you to describe certain aspects of your proposal. You do not need to repeat those answers on this page. (Lead agencies may modify this form to include additional specific information on project description.)*

**The Plan is organized into the following chapters (which includes scope of work/projects):**

**Chapter 1 – Description of Water System, presents information on ownership and management of the water system, system background data, an inventory of existing system facilities, related planning documents, existing and future service areas and characteristics, and service area agreements and policies.**

**Chapter 2 – Basic Planning Data, presents the basic planning data used to estimate Okanogan's future water demands. Water demand projections are used in Chapter 3 to evaluate the adequacy of the City's existing water system.**

**Chapter 3 – Water System Analysis, evaluates the ability of the City's existing water system to meet current and future water quality and system demand requirements.**

**Chapter 4 – Water Use Efficiency, includes water use data collection, program development and implementation, recommended measures and level of implementation, conservation programs, and the City's water use efficiency program.**

**Chapter 5 – Source Water Protection, presents the Wellhead Protection Program for the City.**

**Chapter 6 – Operation and Maintenance, presents the City's Operation and Maintenance program, including water system personnel, equipment settings, and safety procedures.**



SEPA Environmental checklist (WAC 197-11-960)

Chapter 7 – Construction Standards, includes water system construction standards and details required for development.

Chapter 8 – Capital Improvement Program, provides a description of the City's proposed 6- and 20-year water system capital improvements. Specifically:

**WATER RIGHTS**

The City plans to file change applications with the Washington State Department of Ecology to consolidate its existing water rights to give the City greater flexibility in managing its water resources.

**AGREEMENTS**

The City plans to review its agreement for the delivery of water for domestic use to the Progressive Flats Water Association.

**SOURCE IMPROVEMENTS**

The City has identified the following source improvements for its 6- and 20-year improvement schedule:

1. Watercress Springs Feasibility Study – Feasibility study to investigate required improvements and costs to rehabilitate the Watercress Springs source, storage and water distribution system (6-year plan).
2. Well Improvements - Install manual transfer switches and motor soft starts at Wells No. 2, 3, 4, and 5 and two standby generators capable of serving any of these wells. Standby power required to improve source reliability due to inadequacies in the power grid and to meet Department of Health alternate design concept requirements (6-year plan).
3. Well No. 3 Inspection – Remove submersible turbine pump and perform video inspection of Well No. 3 (6-year plan).
4. Murray Street Master Meter – Demolish the existing building and install the master meter in a vault (6-year plan).
5. Murray Street Booster Pump Station – Construct new Murray Street booster pump station capable of serving future Murray Reservoir, including two booster pumps with pitless adapters, building for electrical and control equipment, including variable frequency drive motors (6-year plan).
6. Well No. 4 Bypass – Bypass piping improvements at Well No. 4 (6-year plan).
7. Well No. 6 (Riverwalk Well) - Investigate feasibility to develop the privately-owned Well No. 6 (Riverwalk Well). This improvement would replace the 48-foot deep well with a new 12" diameter well constructed to municipal standards (20-year).

**STORAGE**

The City has identified the following storage-related improvements for its 20-year improvement schedule:

8. Murray Reservoir - Construct 269,000-gallon reservoir in the Murray pressure zone. The project includes construction of a transfer station for water transfer to the lower zone, as necessary; pressure reducing valve stations in order to provide adequate service throughout the pressure zones; approximately 5,000 feet of 12" PVC C900 water main, valves and appurtenances. These improvements are needed to provide adequate pressures and fire suppression storage for the Murray pressure zone as well as provide additional fire suppression storage for the Lower pressure zone. The project will be constructed concurrently with the Murray booster pump station improvements project (20-year plan).
9. West Reservoirs Improvements - Install security fencing and gates to limit access to the West reservoirs and replace the existing wood-frame truss roof on West Reservoir No. 1 (20-year plan).
10. East Reservoir Improvements - Clean and inspect the East Reservoir and install a center fill pipe (similar to the North Reservoir) to improve mixing (20-year plan).

**TREATMENT**

The City has identified the following treatment improvements for its 6- and 20-year improvement schedule:

11. Arsenic Treatment Facility Feasibility Study – Feasibility study to investigate alternatives and make recommendations for the collection and disposal of arsenic-laced sludge from the arsenic treatment facility (6-year plan).
12. Arsenic Treatment Facility Improvements – Construct sludge collection and disposal facilities in accordance with the findings and recommendations of the arsenic treatment facility feasibility study (6-year).
13. Well Chlorination Improvements - Install chlorination facilities at the City's active well sites (20-year plan).

**TELEMETRY**

The City has identified the following telemetry system improvements for its 6-year improvement schedule:

14. Telemetry System Improvements – The City plans to upgrade the existing telemetry control system with a new base station master computer, PLC at the base station master computer, HMI software, and new programming in order to increase reliability and to add functionality. The new system will control reservoir levels, record data and have the capability of performing additional functions for anticipated needs, such as chlorine residual monitoring at each well site and flow metering of the water delivered to the Progressive Flats Water Association, and to include flow metering from all sources and telemetry for the new Murray Street Booster Pump Station (6-year plan).

**DISTRIBUTION**

The City has identified the following distribution system improvements for its 6- and 20 year improvement schedule:



SEPA Environmental checklist (WAC 197-11-960)

15. 5th Avenue Water Main Replacement – This improvement consists of the replacement of the existing 6” CI water line with a new 12” water line on 5th Avenue from Spruce Street to Oak Street (6-year plan).
16. Elmway Water Main Extension (Phase 3) – This improvement consists of the construction of a new 12” water line on 2nd Avenue (SR 215) from River Street to Shell Rock Point to extend municipal water service to the City’s northern city limits (6-year plan).
17. 1st Avenue Water Main – This improvement consists of the replacement of the existing 6” AC water line with a new 8” water line on 1st Avenue from Ione Street to Conconully Street and the construction of a new 8” water line from Conconully Street to Tyee Street to provide system looping (6-year plan).
18. South Okanogan Water System Improvements – This improvement consists of the replacement of existing 6” water lines on Ione Street, Gordon Street, 2nd Avenue, Nickell Street, and at the entrance to the City’s wastewater treatment plant, with new 8” and 12” water lines to improve fire flow in these areas (6-year plan).
19. Rodeo Trail Water Main Replacement – This improvement consists of the replacement of existing 2 ½” and 8” water lines on Rodeo Trail with a new 12” water line and extension to the Central Valley Sports Complex to improve fire flows in this area and provide for future expansion to the north (6-year plan).
20. Highland Drive Water Main Replacement – This improvement consists of the replacement of existing 2 ½” GI water pipe on Highland Drive and east to Richlyn Avenue with new 8” water main to improve fire flows in this area (6-year plan).
21. Tacoma Street/Spokane Street Water Main Loop – This improvement consists of the replacement of existing 4” AC and CI water pipe with new 8” water lines on Tacoma Street, 4th Avenue, and Spokane Street to improve fire flows in this area (6-year plan).
22. 2nd Avenue South Water Main Replacement – This improvement consists of the replacement of existing 6” AC and DI water main pipe on 2nd Avenue from Ione Street to Rose Street with new 8” water main (20-year plan).
23. Viewmont Drive Water Main Replacement – This improvement consists of the replacement of the existing 6” AC water main on Viewmont Drive from Highland Drive to Crestview Drive with new 8” water main pipe and the extension of 8” water main on Delmav to Crestview Drive to improve fire flows in the area, provide looping on Delmav, and improve water transmission to the central grid from the Highland Reservoir (20-year plan).
24. 3rd Avenue North Water Main Replacement – This improvement consists of the replacement of the existing 6” AC and CI water line on 3rd Avenue North from June Street to Greta Street with new 8” water main to improve fire flows in the area (20-year plan).
25. Mill Street Water System Improvements – This improvement consists of the construction of an 8” water line on Mill Street and 9th Avenue to improve fire flows in the area (20-year plan).
26. Airport Booster Pump Station – This improvement consists of the construction of a new booster pump station to address fire flow deficiencies near the airport (20-year plan).
27. 2nd Avenue Water System Improvements – This improvement consists of the installation of an 8” water main on 2nd Avenue from Oak Street to Greta Street (20-year plan).

Chapter 9 – Capital Improvement Financing, analyzes past revenue and expenses and revenue and cash flow to fund the CIP.

12. *Location of the proposal.* Give sufficient information for a person to understand the precise location of your proposed project, including a street address, if any, and section, township, and range, if known. If a proposal would occur over a range of area, provide the range or boundaries of the site(s). Provide a legal description, site plan, vicinity map, and topographic map, if reasonably available. While you should submit any plans required by the agency, you are not required to duplicate maps or detailed plans submitted with any permit applications related to this checklist.

City wide and projects within the Service Area Boundary (UGA-2) of the greater surrounding area of the City of Okanogan, Washington primarily located in Sections 2, 3, 4, 5, 6, 8, 9, 10, 11, 15, 16, 17, 18, 19, 20 and 21 of Township 33 N., Range 26 E WM. and a portion of Section 33 of Township 34 N., Range 26 E.WM., Okanogan County. Mapping of the specific locations of each project is also shown in the Water System Plan Fig 8.1. See attached maps.

**B. ENVIRONMENTAL ELEMENTS**

**1. Earth**

**a. General description of the site**

(circle one): Flat, rolling, hilly, steep slopes, mountainous,  
other:

The City of Okanogan is located in north central Washington. The City sits on a narrow river plain with steeply rising side slopes. The City lies mostly to the west of the Okanogan River, a portion of the City lies on tribal land, with the Colville Confederated Tribal boundary coincident with the eastern bank of the Okanogan River. The City continues to grow primarily to the south and west with limited growth to the North due to the close proximity to Omak. The commercial and industrial areas of Okanogan are located mostly on



SEPA Environmental checklist (WAC 197-11-960)

the east side of the City with the residential area located mainly in the west along the base of the surrounding hills. The topography in the City rises from approximately 820 feet above mean sea level (msl) at the Okanogan River, to approximately 1,200 feet above msl on the hillsides just to the west of the City.

b. *What is the steepest slope on the site (approximate percent slope)?*

Generally the community has a defined slope towards the river of 8 to 10% overall, there are steep slopes that are 67% for a rises of 50' to 100'. Project areas do include all slopes.

c. *What general types of soils are found on the site (for example, clay, sand, gravel, peat, muck)? If you know the classification of agricultural soils, specify them and note any agricultural land of long-term commercial significance and whether the proposal results in removing any of these soils.*

Generally glacial till, with flood plain alluvial fan consisting of Pogue–Cashmont–Cashmere Association and Colville-Okanogan Association. (Loam, sandy gravel (SWG)).

d. *Are there surface indications or history of unstable soils in the immediate vicinity? If so, describe.*

None known.

e. *Describe the purpose, type, total area, and approximate quantities and total affected area of any filling, excavation, and grading proposed. Indicate source of fill.*

Generally common trench excavations and back-fill for the laying and replacement of pipes in the areas shown on the map. Any backfill material will be from approved sites for bedding and consolidated fills of excavations.

f. *Could erosion occur as a result of clearing, construction, or use? If so, generally describe.*

In specific areas yes, all projects and specifically in areas in the vicinity of critical area will have detailed site specific best management controls.

g. *About what percent of the site will be covered with impervious surfaces after project construction (for example, asphalt or buildings)?*

There will be no material change from the existing conditions as a result of all of the proposed projects; areas with paving will be repaved. Areas with natural covering will be regraded and planted as appropriate.

h. *Proposed measures to reduce or control erosion, or other impacts to the earth, if any:*

Generally all activities will be designed to comply with the Eastern Washington Storm-water Manual and where applicable a Critical Areas Report and/or Geotechnical Report will be required and include detailed measures to control adverse impacts to the earth.

## 2. Air

a. *What types of emissions to the air would result from the proposal during construction, operation, and maintenance when the project is completed? If any, generally describe and give approximate quantities if known.*

Minor dust and exhaust from equipment during construction of projects; other none.

b. *Are there any off-site sources of emissions or odor that may affect your proposal? If so, generally describe.*

None known.

c. *Proposed measures to reduce or control emissions or other impacts to air, if any:*

Sprinkling will be used as needed during construction to control fugitive dust.

## 3. Water

a. *Surface Water:*

1) *Is there any surface water body on or in the immediate vicinity of the site (including year-round and seasonal streams, saltwater, lakes, ponds, wetlands)? If yes, describe type and provide names. If appropriate, state what stream or river it flows into.*

Salmon Creek and Elgin Creek both have their confluences with the Okanogan River within the city; the Okanogan River flows southward and joins the Columbia River some 26 miles to the South.

2) *Will the project require any work over, in, or adjacent to (within 200 feet) the described waters? If yes, please describe and attach available plans.*

Yes, portions of the 1<sup>st</sup> Ave, 2<sup>nd</sup> Ave, Mill St and Elmway will be within 200', Salmon Creek, Elgin Creek and the Okanogan River will be crossed with these improvements.

3) *Estimate the amount of fill and dredge material that would be placed in or removed from surface water or wetlands and indicate the area of the site that would be affected. Indicate the source of fill material.*

Not specifically determined; crossings will likely be accomplished by boring methods, see map..

4) *Will the proposal require surface water withdrawals or diversions? Give general description, purpose, and approximate quantities if known.*

None known.



SEPA Environmental checklist (WAC 197-11-960)

5) Does the proposal lie within a 100-year floodplain? If so, note location on the site plan.

Yes, approximately 25% of the City is within the 100-year floodplain; 1<sup>st</sup> Ave, 2<sup>nd</sup> Ave, Elmway projects, as well as, Salmon Creek and Okanogan River crossings, will be in the floodplain.

6) Does the proposal involve any discharges of waste materials to surface waters? If so, describe the type of waste and anticipated volume of discharge.

None specifically planned; likely discharges may include well test pumps, trench de-watering and construction stormwater, all discharges (if any) will conform to stormwater permitting standards.

b. Ground Water:

1) Will groundwater be withdrawn from a well for drinking water or other purposes? If so, give a general description of the well, proposed uses and approximate quantities withdrawn from the well. Will water be discharged to groundwater? Give general description, purpose, and approximate quantities if known.

There may be minimal dewatering of trenches during construction. Additionally, the proposed well will withdraw groundwater in compliance with Washington State Department of Health, Department of Ecology and Confederated Tribes of the Colville Indian Reservation guidelines and regulations. Ground water will be used for municipal purposes.

2) Describe waste material that will be discharged into the ground from septic tanks or other sources, if any (for example: Domestic sewage; industrial, containing the following chemicals. . . ; agricultural; etc.). Describe the general size of the system, the number of such systems, the number of houses to be served (if applicable), or the number of animals or humans the system(s) are expected to serve.

None.

c. Water runoff (including stormwater):

1) Describe the source of runoff (including storm water) and method of collection and disposal, if any (include quantities, if known). Where will this water flow? Will this water flow into other waters? If so, describe.

Rain and snow melt follow gravity paths in an informal manner, primarily in road/street side bar ditches. In commercial core of the city such water is collected in the stormwater system and conveyed to the Okanogan River.

2) Could waste materials enter ground or surface waters? If so, generally describe.

Not as a result of these projects with proper controls.

3) Does the proposal alter or otherwise affect drainage patterns in the vicinity of the site? If so, describe.

Proposed utility work will generally not change existing conditions.

d. Proposed measures to reduce or control surface, ground, and runoff water, and drainage pattern impacts, if any: Compliance with stormwater design standards.

4. Plants

a. Check the types of vegetation found on the site:

\_\_\_ deciduous tree: alder, maple,

aspen,

other

\_\_\_ evergreen tree: fir, cedar, pine,

other

\_\_\_ shrubs

\_\_\_ grass

\_\_\_ pasture

\_\_\_ crop or grain

\_\_\_ Orchards, vineyards or other

permanent

crops.

\_\_\_ wet soil plants: cattail,

buttercup,

bulrush,

skunk

cabbage,

other

\_\_\_ water plants: water lily, eelgrass,

milfoil,

other

\_\_\_ other types of vegetation

There is a full complement of vegetation types normal to Northcentral Washington in the UGA-2.

b. What kind and amount of vegetation will be removed or altered?

Generally none, most of the work is located in established right-of-ways; identified Murray Reservoir and Okanogan River crossing will require vegetation removal and replanting.

c. List threatened and endangered species known to be on or near the site.

None known.

d. Proposed landscaping, use of native plants, or other measures to preserve or enhance vegetation on the site, if any:

SEPA Environmental checklist (WAC 197-11-960)

To be developed project plans will include provisions to preserve and enhance native vegetation and abatement of invasive and noxious vegetation.

e. List all noxious weeds and invasive species known to be on or near the site.

There is a full complement of noxious and invasive present in the UGA-2.

5. Animals

a. List any birds and other animals which have been observed on or near the site or are known to be on or near the site. Examples include:

birds: hawk, heron, eagle, songbirds, other:

mammals: deer, bear, elk, beaver, other:

fish: bass, salmon, trout, herring, shellfish, other:

b. List any threatened and endangered species known to be on or near the site.

Steelhead are listed as threatened and Bald Eagle are listed as threatened.

c. Is the site part of a migration route? If so, explain.

The Okanogan Valley is a fringe of the Pacific Flyway for migratory birds, mostly ducks and geese. The Okanogan River serves as the migratory route for several species of fish.

d. Proposed measures to preserve or enhance wildlife, if any:

No special measures proposed.

e. List any invasive animal species known to be on or near the site.

Feral cats & dogs and non-native crayfish.

6. Energy and natural resources

a. What kinds of energy (electric, natural gas, oil, wood stove, solar) will be used to meet the completed project's energy needs? Describe whether it will be used for heating, manufacturing, etc.

Electricity will be used for pumping and treatment of water within the system.

b. Would your project affect the potential use of solar energy by adjacent properties?

If so, generally describe.

No.

c. What kinds of energy conservation features are included in the plans of this proposal?

List other proposed measures to reduce or control energy impacts, if any:

Appropriate selection of pumps; controlling wasted water (leaks, unaccounted for water loss, etc.).

7. Environmental health

a. Are there any environmental health hazards, including exposure to toxic chemicals, risk of fire and explosion, spill, or hazardous waste, that could occur as a result of this proposal?

If so, describe.

No.

Describe any known or possible contamination at the site from present or past uses.

None known.

1) Describe existing hazardous chemicals/conditions that might affect project development and design. This includes underground hazardous liquid and gas transmission pipelines located within the project area and in the vicinity.

None known.

2) Describe any toxic or hazardous chemicals that might be stored, used, or produced during the project's development or construction, or at any time during the operating life of the project.

None.

3) Describe special emergency services that might be required.

None.

4) Proposed measures to reduce or control environmental health hazards, if any:

No special measures.

b. Noise

1) What types of noise exist in the area which may affect your project (for example: traffic, equipment, operation, other)?

None.

2) What types and levels of noise would be created by or associated with the project on a short-term or a long-term basis (for example: traffic, construction, operation, other)? Indicate what hours noise would come from the site.

Normal construction noises while the projects are being constructed.

3) Proposed measures to reduce or control noise impacts, if any:

No special measures.



SEPA Environmental checklist (WAC 197-11-960)

8. *Land and shoreline use*

- a. *What is the current use of the site and adjacent properties? Will the proposal affect current land uses on nearby or adjacent properties? If so, describe.*

The City of Okanogan is zoned primarily residential with commercial and light industrial areas spread through the City, with a business district located in a central location. All proposed construction will be within public rights-of-way, easements, and on City-owned properties.

- b. *Has the project site been used as working farmlands or working forest lands? If so, describe. How much agricultural or forest land of long-term commercial significance will be converted to other uses as a result of the proposal, if any? If resource lands have not been designated, how many acres in farmland or forest land tax status will be converted to nonfarm or nonforest use?*

A significant portion of the UGA-2 has been or is currently, in agriculture use. The proposed reservoir site may be located on or near current working farmlands, depending on site selection, which is unknown at this time.

- 1) *Will the proposal affect or be affected by surrounding working farm or forest land normal business operations, such as oversize equipment access, the application of pesticides, tilling, and harvesting? If so, how:*

No.

- c. *Describe any structures on the site.*

Generally, most of the improvements are located in areas with established streets, bridges, bar-ditches and culverts.

- d. *Will any structures be demolished? If so, what?*

To be determined.

- e. *What is the current zoning classification of the site?*

Lands within the city are classified into 15 separate zoning districts (see map); the remaining lands within the UGA-2 which are County are Minimum Requirement District and those that are within the Colville Reservation are Special Requirement.

- f. *What is the current comprehensive plan designation of the site?*

Lands which are within the city are designated into nine designations (see map); areas which are County are designated as agricultural, residential, and industrial with an overlay of City Expansion Area (County term for UGA); lands within the Colville Reservation are designated as Special Requirement.

- g. *If applicable, what is the current shoreline master program designation of the site?*

Lands which are within the city are designated as Conservancy, Rural, Suburban and Urban; lands which are within the County are similarly designated and lands within the Colville Reservation also include some areas of Natural.

- h. *Has any part of the site been classified as a critical area by the city or county? If so, specify.*

Yes, 1<sup>st</sup> Ave, 2<sup>nd</sup> Ave and Elmway projects are located in areas prone to flooding; 1<sup>st</sup> Ave and 2<sup>nd</sup> Ave projects are located in the vicinity of wetlands; Mill St and Elmway in the vicinity of riparian habitat; Viewmont and Murray Reservoir in the vicinity of steep slopes.

- i. *Approximately how many people would reside or work in the completed project?*

The current population of the City of Okanogan is 2,576 (2013) an additional estimated 25% live in the UGA-2.

- j. *Approximately how many people would the completed project displace?*

Proposed project will not lead to displacements.

- k. *Proposed measures to avoid or reduce displacement impacts, if any:*

No special measures seen as necessary.

- l. *Proposed measures to ensure the proposal is compatible with existing and projected land uses and plans, if any:*

The city did an extensive review of existing land use plans to identify needed updates to the existing water system plans and to identify needed projects and ensure compatibility.

- m. *Proposed measures to ensure the proposal is compatible with nearby agricultural and forest lands of long-term commercial significance, if any:*

There are no designated long term lands within the city's UGA-2.

9. *Housing*

- a. *Approximately how many units would be provided, if any? Indicate whether high, middle, or low-income housing.*

None.

- b. *Approximately how many units, if any, would be eliminated? Indicate whether high, middle, or low-income housing.*

None.

- c. *Proposed measures to reduce or control housing impacts, if any*

No measures are proposed.



SEPA Environmental checklist (WAC 197-11-960)

10. *Aesthetics*

- a. *What is the tallest height of any proposed structure(s), not including antennas; what is the principal exterior building material(s) proposed?*

**The Murray Reservoir may be 25 to 35' in height and will have a painted metal or concrete exterior.**

- b. *What views in the immediate vicinity would be altered or obstructed?*

**None materially.**

- c. *Proposed measures to reduce or control aesthetic impacts, if any*

**Reservoir will likely have a muted color to blend into the hill side.**

11. *Light and glare*

- a. *What type of light or glare will the proposal produce? What time of day would it mainly occur?*

**Security/work lighting may be installed at facilities.**

- b. *Could light or glare from the finished project be a safety hazard or interfere with views?*

**No.**

- c. *What existing off-site sources of light or glare may affect your proposal?*

**None.**

- d. *Proposed measures to reduce or control light and glare impacts, if any:*

**Generally any lighting will be occupancy based. In the vicinity of residences, wetlands and habitat areas lighting will be required to be directed away from such areas.**

12. *Recreation*

- a. *What designated and informal recreational opportunities are in the immediate vicinity?*

**Within the UGA-2 there are several parks, playfields, museums, trails and informal recreation.**

- b. *Would the proposed project displace any existing recreational uses? If so, describe.*

**No.**

- c. *Proposed measures to reduce or control impacts on recreation, including recreation opportunities to be provided by the project or applicant, if any:*

**No special measures.**

13. *Historic and cultural preservation*

- a. *Are there any buildings, structures, or sites, located on or near the site that are over 45 years old listed in or eligible for listing in national, state, or local preservation registers located on or near the site? If so, specifically describe.*

**Yes, there are several known and listed structures and sites within the UGA-2 and near proposed work sites.**

- b. *Are there any landmarks, features, or other evidence of Indian or historic use or occupation? This may include human burials or old cemeteries. Are there any material evidence, artifacts, or areas of cultural importance on or near the site? Please list any professional studies conducted at the site to identify such resources.*

**Yes, there are several known and listed sites within the UGA-2 and near proposed work sites.**

- c. *Describe the methods used to assess the potential impacts to cultural and historic resources on or near the project site. Examples include consultation with tribes and the department of archeology and historic preservation, archaeological surveys, historic maps, GIS data, etc.*

**SEPA consultation with the History Department of the Confederated Tribes of the Colville Reservation and State Department of Archaeology and previous archaeological surveys.**

- d. *Proposed measures to avoid, minimize, or compensate for loss, changes to, and disturbance to resources. Please include plans for the above and any permits that may be required.*

**All proposed construction projects identified in the Plan will include an Unanticipated Discovery Plan such that during construction, if any locations are found to contain objects of suspected historical interest, work will halt immediately and appropriate State or tribal authorities will be contacted. Areas that are suspect to findings will include a cultural resource survey at the design stage to ensure the best course of action. Some projects will include on-site monitoring by qualified professionals to ensure that no damage is done to the resources.**

14. *Transportation*

- a. *Identify public streets and highways serving the site or affected geographic area and describe proposed access to the existing street system. Show on site plans, if any.*

**The UGA-2 is primarily served by Hwy 97 (North & South), Hwy 20 (West & East), Conconully Highway, Salmon Creek Road, B&O Road, Cameron Lake Road and Rodeo Trial Road.**

- b. *Is the site or affected geographic area currently served by public transit? If so, generally describe. If not, what is the approximate distance to the nearest transit stop?*

**The UGA-2 is served by TranGO (Okanogan County Transit Authority) with several transit stops.**



SEPA Environmental checklist (WAC 197-11-960)

c. How many additional parking spaces would the completed project or non-project proposal have? How many would the project or proposal eliminate?

None.

d. Will the proposal require any new or improvements to existing roads, streets, pedestrian, bicycle or state transportation facilities, not including driveways? If so, generally describe (indicate whether public or private).

None directly.

e. Will the project or proposal use (or occur in the immediate vicinity of) water, rail, or air transportation? If so, generally describe.

The UGA-2 is served by a rail line which follows the valley floor (long term planning projects will likely include crossing the rail line), and Legion Airport; work at the airport includes a booster station project.

f. How many vehicular trips per day would be generated by the completed project or proposal? If known, indicate when peak volumes would occur and what percentage of the volume would be trucks (such as commercial and nonpassenger vehicles). What data or transportation models were used to make these estimates?

None directly.

g. Will the proposal interfere with, affect or be affected by the movement of agricultural and forest products on roads or streets in the area? If so, generally describe.

Some of the projects will be located on streets used to transport agricultural and forest products; while projects are taking place appropriate detour routes will be established.

h. Proposed measures to reduce or control transportation impacts, if any:

Whenever possible, scheduled utility work will coincide with scheduled public street improvements.

15. Public services

a. Would the project result in an increased need for public services (for example: fire protection, police protection, public transit, health care, schools, other)? If so, generally describe.

No.

b. Proposed measures to reduce or control direct impacts on public services, if any.

The project is to specifically reduce existing and estimated future impacts of other projects on public services (Fire protection and water service).

16. Utilities

a. Circle utilities currently available at the site:

electricity, natural gas, water, refuse service, telephone, sanitary sewer, septic system,  
other \_\_\_\_\_

b. Describe the utilities that are proposed for the project, the utility providing the service, and the general construction activities on the site or in the immediate vicinity which might be needed.

Proposal is the adoption of a plan and the implementation of a utility plan; see project description above for the specifics.

C. Signature

The above answers are true and complete to the best of my knowledge. I understand that the lead agency is relying on them to make its decision.

Signature:



Name of signee Shawn Davisson

Position and Agency/Organization, Public Works Director, City of Okanogan, Washington

Date Submitted: 12/15/15

D. supplemental sheet for nonproject actions

1. How would the proposal be likely to increase discharge to water; emissions to air; production, storage, or release of toxic or hazardous substances; or production of noise?

The City of Okanogan's Water System Plan recommends capital improvement projects related to the City's water system, including improvements to wells, reservoirs, water distribution piping, and booster stations. All proposed projects will be completed in compliance with all state and federal regulations and City and County ordinances. During the construction of the proposed water system improvements, noise typical of a construction site will be generated, and the operation of construction equipment will result in engine exhaust.

Proposed measures to avoid or reduce such increases are:

Existing regulations require a higher degree of attention to detail with respect to such items when considered to be located in or the vicinity of critical areas.

2. How would the proposal be likely to affect plants, animals, fish, or marine life?

SEPA Environmental checklist (WAC 197-11-960)

The majority of the work will take place within asphalt or gravel surfaced rights of way, except for the construction of a new reservoir, which could require removal of vegetation in the area where the reservoir is constructed. Any disturbed vegetation will be replanted, and minimal impact to animal life is expected.

*Proposed measures to protect or conserve plants, animals, fish, or marine life are:*

**Compliance with existing regulations established to protect such resources such as critical areas and shoreline.**

3. *How would the proposal be likely to deplete energy or natural resources?*

**Not likely.**

*Proposed measures to protect or conserve energy and natural resources are:*

**Proposal will reduce unaccounted for (loss) water from leaks etc. and will further enhance wellhead protection.**

4. *How would the proposal be likely to use or affect environmentally sensitive areas or areas designated (or eligible or under study) for governmental protection; such as parks, wilderness, wild and scenic rivers, threatened or endangered species habitat, historic or cultural sites, wetlands, floodplains, or prime farmlands?*

**Where planned projects are located in such areas, such work is necessary to accomplish needed redundancy in the management of the overall system.**

*Proposed measures to protect such resources or to avoid or reduce impacts are:*

**Existing regulations require site specific study of a proposal's effect on such resources and demonstration that adequate measures will be in place to protect the resource before action is taken.**

5. *How would the proposal be likely to affect land and shoreline use, including whether it would allow or encourage land or shoreline uses incompatible with existing plans?*

**The proposed plan will encourage new development that is consistent with existing plans.**

*Proposed measures to avoid or reduce shoreline and land use impacts are:*

**The development of the proposed plan included a detailed review for compatibility of the existing plans to ensure conformance.**

6. *How would the proposal be likely to increase demands on transportation or public services and utilities?*

**Some of the proposed projects may increase demands on the system by virtue of the utility being readily available in new areas.**

*Proposed measures to reduce or respond to such demand(s) are:*

**These new areas/demands were accounted for in the development of the plan.**

7. *Identify, if possible, whether the proposal may conflict with local, state, or federal laws or requirements for the protection of the environment.*

**There are no known conflicts.**

**APPENDIX J**

**NESTING APPROVAL LETTER**



# CITY OF OKANOGAN

JON CULP, MAYOR



Date December 2, 2015

Dear Mayor Culp,

It is my understanding that in order to obtain approval from the Washington State Department of Health for the City's 2015 Water System Plan; the City must provide a letter from the local fire marshal indicating concurrence with the assumptions used to determine the requirements of the City's emergency water supplies. After reviewing the City's approach, I have the following comments:

Concerning storage volumes to be provided in the City's water system, it is my understanding that per WAC 246-290-235(4), standby and fire suppression storage volumes may be nested with the larger of the two volumes being the minimum available, provided the local fire protection authority does not require them to be additive.

As fire chief of the Okanogan Fire Department, I agree that the City may "nest" the smaller of these two volumes within the larger volume.

We believe that this decision is valid for the City's current water system plan 6-year planning period, but should be reevaluated during the development of the next water system plan.

Sincerely,

A handwritten signature in black ink, appearing to read "Jerod Gavin", followed by a horizontal line.

Jerod Gavin  
Okanogan Fire Chief

**APPENDIX K**

**WATER RIGHTS DOCUMENTATION**



## CITY OF OKANOGAN

### **Ground Water Rights:**

**Ground Water Certificate (GWC) No. 5327:** 650 gpm, 700 ac-ft per year, Well No. 3. The annual portion withdrawn under this water right certificate and GWC 265-C (relinquished), GWC 266-D, GWC 369-A, GWC 3410-A and SWC 592 (relinquished) is not to exceed 700 ac-ft/yr. The instantaneous quantity, 650 gpm, issued as additive.

**GWC No. 266-D:** 100 gpm, 29 ac-ft annually, Well No. 1. This certificate was initially withdrawn from a 25 ft deep, dug well located in Alma Park. The rights were transferred to be withdrawn from Well No. 1, located approximately 50 ft west of the Alma Park Well. The period of use is restricted to April 1 through October 31 each year as the use was originally for only park and swimming pool uses. The instantaneous quantity, 100 gpm, is additive. The annual quantity, 29 ac-ft/yr is non-additive (see GWC 5327).

**GWC No. 369-A:** 350 gpm, 200 ac-ft annually, Well No. 5. The instantaneous quantity, 350 gpm, is additive. The annual quantity, 200 ac-ft/yr is non-additive (see GWC 5327). This certificate initially authorized the City to withdraw 500 gpm, 200 ac-ft annually for municipal supply. However, on 8/23/1988, in a decision by the Department of Ecology, the withdrawal rate was reduced to 350 gpm as a condition of transferring this right from Well No. 1 to Well No. 3. Although the City did not appeal Ecology's decision, there remains a question as to whether this reduction was justified considering that this is a municipal water right.

**GWC No. 3410-A:** 200 gpm, 320 ac-ft annually, Well No. 2. This certificate was issued supplemental to certificates SWC 592 (relinquished), GWC 265 (relinquished), GWC 266-D and GWC 369; consequently, the annual quantity is non-additive. The instantaneous quantity, 200 gpm, is additive.

**CG-4-23854C:** 550 gpm, 400 ac-ft per year, Well No. 4. Both quantities are additive. The City filed for and received temporary authorization to transfer 300 gpm of these rights to Well No. 5 for one year, from August 7, 2006 to August 1, 2007 while the City completes its arsenic treatment project on Well No. 4.

**GWC No. G4-29193:** 300 gpm, 400 ac-ft annually, Well No. 5. The annual quantity of this water right issued non-additive to certificates GWC 266-D, GWC 369-D, GWC 3410-A, GWC 5327-A and G4-23854C and Water Right Claim No. 000052 (should a right be confirmed following adjudication). No water is allowed to be withdrawn under this authorization when the Okanogan River is below the minimum flows identified in the authorization. The instantaneous quantity was reduced from 650 gpm to 300 gpm when GWC No. 369-A was transferred to Well No. 5.

**GWC No. G4-3838-A:** 50 gpm, 39 ac-ft, Well No. 3. This certificate is being transferred from the Progressive Flats Water Association (PFWA) wells to City of Okanogan's Well No. 3. It appears that the City needs to file for an extension of the project development schedule. Both instantaneous and annual rights are additive.

**GWC No. G4-30573-A:** 20 gpm, 6.3 ac-ft, Well No. 3. This certificate is being transferred from the PFWA wells to City of Okanogan's Well No. 3. Both instantaneous and annual rights are additive. Ecology requested in a letter to the PFWA (2/16/07) that a request for an extension of the project development schedule be filed with the Department of Ecology (DOE). In the letter from Ecology, it is indicated that the authorized change to the water right required that construction begin by 10/1/06, which had apparently not begun as of 2/16/07.

**SWR Certificate 592:** In about 1930, the City completed a well about 500 feet from the bank of the Okanogan River at about 1<sup>st</sup> and Queen Streets to supplement the City's sole supply of water at the time, the Shull Springs supply on Salmon Creek. According to the remarks on the permit application, the City applied for the permit in 1931, one or two years after completing the well. A certificate issued in 1932 for 1.5 cfs (about 670 gpm). The City voluntarily relinquished the right in 1970.

**Claim:**

**Surface Water Right (SWR) Claim 000052:** This source is commonly referred to as "Watercress Springs", "Shull Springs", or simply "The Springs". On February 24, 1970, the City filed a water right claim for this source, listing the date of first of use to be 1908, in the amounts of 300 gpm and 484 ac-ft per year. It has been reported that the spring flow currently varies from 175 gpm to 300 gpm.

GWC – 05327

Johnson & Johnson  
Attorneys at Law  
Okanogan, Wash.

# Report of Examination on Ground Water

Received date September 13, 1963 Date of exam October 15, 1963 Appl. No. 4878

Name City of Okanogan Address Okanogan, Washington

Type of works a well Dimensions 12" x 117'

Progress of works Not started

Quantity applied for 650 g.p.m. \_\_\_\_\_ acre-feet per year

Government Lot 2 (NW)  
Legal sub. 503 (SW) Sec. 9 Twp. 33 N. Rge. 26 E. County Okanogan

Use Municipal water supply

Irrigation-acreage: Present \_\_\_\_\_ Planned \_\_\_\_\_ Feasible \_\_\_\_\_

Municipal: Population 2,500 as of 1968

Industrial \_\_\_\_\_

Time pump will be operated continuously

Other water rights appurtenant to this land S.W. Cert. 592; G.W. Certs. 369, 3410, 265-A & 266-A

Proximity to existing works, springs, wells, or streams Okanogan River, 800 feet southwesterly;  
approximately 60 feet above river level

Area \_\_\_\_\_ Sub-area \_\_\_\_\_ Zone \_\_\_\_\_

## RECOMMENDATIONS

Approved for 650 g.p.m. 700 acre-feet per year, subject to existing water rights. (1 acre-foot 325,850 gallons.)

The installation of an access port to well as described in attached Ground Water Bulletin No. 1 is recommended.

Use of the waters to be appropriated under this application will be for a public water supply. Clean Air Act of Health rules require every owner of a public water supply to obtain written approval from the State Director of Health prior to any new construction or alterations of a public water supply. The applicant is advised to contact the Washington State Department of Health, Fourth Floor, Public Health Building, Olympia, with regard to the need for compliance.

The water requirement for the Town of Okanogan is calculated on a per capita demand of 250 gallons per day or 700 acre-feet per year for an estimated population of 2,500 persons as of 1968.

The Town of Okanogan holds the following Certificates of Water Right:

- G.W. No. 265-D for 164 acre-feet per year
- No. 266-D for 29 acre-feet per year
- No. 369-A for 200 acre-feet per year
- No. 3410-A for 320 acre-feet per year
- S.W. No. 592 for 1.50 cfs for a total of 713 acre-feet per year.

1421

(over)

Small shall issue subject to the following provision: "Based on a permanent supply of Small Water Certificates 343-D, 344-D, 349-A, 341B-A and Small Water Certificate N, 1972, the total withdrawal shall not exceed 700 acre-feet per year, less any amount withdrawn under the above certificates."

Signed this 4th day of November, 1963.  
Division of Water Resources

  
ERNEST E. LAVASSEUR, Director

000052CL





STATE OF WASHINGTON  
DEPARTMENT OF WATER RESOURCES  
DIVISION OF WATER MANAGEMENT

**WATER RIGHT CLAIM**

RECEIVED  
DEPT. OF WATER RESOURCES

FEB 24 7000076

CASH  OTHER  NONE

1. NAME City of Okanogan  
ADDRESS c/o City Clerk  
Okanogan, Washington ZIP CODE 98840

2. SOURCE FROM WHICH THE RIGHT TO TAKE AND MAKE USE OF WATER IS CLAIMED: Surface  
(SURFACE OR GROUND WATER)  
W.R.I.A. 49  
(LEAVE BLANK)

A. IF GROUND WATER, THE SOURCE IS \_\_\_\_\_  
B. IF SURFACE WATER, THE SOURCE IS Springs ("Shull Springs")

3. THE QUANTITIES OF WATER AND TIMES OF USE CLAIMED:  
A. QUANTITY OF WATER CLAIMED 300 g.p.m. (All water) PRESENTLY USED 300 g.p.m. (All water)  
(CUBIC FEET PER SECOND OR GALLONS PER MINUTE)  
B. ANNUAL QUANTITY CLAIMED 484 acre-feet per year PRESENTLY USED 484 acre-feet per year  
(ACRE FEET PER YEAR)  
C. IF FOR IRRIGATION, ACRES CLAIMED \_\_\_\_\_ PRESENTLY IRRIGATED \_\_\_\_\_  
D. TIME(S) DURING EACH YEAR WHEN WATER IS USED: Continuously

4. DATE OF FIRST PUTTING WATER TO USE \_\_\_\_\_ MONTH Unknown YEAR 1908  
5. LOCATION OF THE POINT(S) OF DIVERSION/WITHDRAWAL: Shull springs-located between a point 1200 feet west and 800 feet south from the center of Sec. 5 and a point located 100 feet west and 350 feet north of the south quarter corner of Sec. 5; Said points BEING WITHIN NEARLY SE 1/4 OF SECTION 5 T. 33 N. R. 26 (EXAM) W.M.  
See attached map  
IF THIS IS WITHIN THE LIMITS OF A RECORDED PLATTED PROPERTY, LOT \_\_\_\_\_ BLOCK \_\_\_\_\_ OF \_\_\_\_\_

(GIVE NAME OF PLAT OR ADDITION)  
6. LEGAL DESCRIPTION OF LANDS ON WHICH THE WATER IS USED: Within the corporate limits of the City of Okanogan, Washington

COUNTY Okanogan  
7. PURPOSE(S) FOR WHICH WATER IS USED: Municipal water supply  
8. THE LEGAL DOCTRINE(S) UPON WHICH THE RIGHT OF CLAIM IS BASED: Appropriation

DO NOT USE THIS SPACE  
THE FILING OF A STATEMENT OF CLAIM DOES NOT CONSTITUTE AN ADJUDICATION OF ANY CLAIM TO THE RIGHT TO USE OF WATERS AS BETWEEN THE WATER USE CLAIMANT AND THE STATE OR AS BETWEEN ONE OR MORE WATER USE CLAIMANTS AND ANOTHER OR OTHERS. THIS ACKNOWLEDGEMENT CONSTITUTES RECEIPT FOR THE FILING FEE.  
DATE RETURNED \_\_\_\_\_ REGISTRY NUMBER \_\_\_\_\_  
THIS HAS BEEN ASSIGNED WATER RIGHT CLAIM REGISTRY NO. **FEB 24 7000052**  
*John H. Linder*  
ASSISTANT DIRECTOR DIVISION OF WATER MANAGEMENT - DEPARTMENT OF WATER RESOURCES

I HEREBY SWEAR THAT THE ABOVE INFORMATION IS TRUE AND ACCURATE TO THE BEST OF MY KNOWLEDGE AND BELIEF  
X *R. E. Johnson*  
DATE February 24, 1970  
IF CLAIM FILED BY DESIGNATED REPRESENTATIVE PRINT OR TYPE FULL NAME AND MAILING ADDRESS OF AGENT BELOW  
R. E. Johnson, City Attorney  
Okanogan, Washington 98840

ADDITIONAL INFORMATION RELATING TO WATER QUALITY AND OF WELL CONSTRUCTION IS AVAILABLE

A FEE OF \$7.00 MUST ACCOMPANY THIS WATER RIGHT CLAIM  
ORIGINAL  
DWR

RETURN ALL THREE COPIES WITH CLAIMANT'S INITIALS ALONG WITH YOUR FEE TO DEPARTMENT OF WATER RESOURCES, DIVISION OF WATER MANAGEMENT, UNION AVENUE BUILDING, OLYMPIA, WASHINGTON 98501

CG4-GWC369-A

PROGRESS SHEET - APPLICATION FOR CHANGE ON

CHOWC 369-A

509 422 3600

NAME: CITY OF OKANOGAN

R. COOK  
Phone: 206 284 0860

ADDRESS: PO BOX 752 OKANOGAN WA 98840

City State ZIP

PURPOSE OF APPLICATION: CHANGE POW

TARGET: 64-\*00321 CWRLS

(00321/00341/00369) PROTESTED

APPLICATION received 7-20-87 date Initial \$10 fee received  Yes ( ) No

Statement of additional exam fee \$ \_\_\_\_\_ Sent \_\_\_\_\_ date Rec'd \_\_\_\_\_ date

PUBLICATION:

Approved by: BP Date 7-29-87 Notice Sent AUG 4 1987 date

PROTESTS: 9-15-87 date By: Philip W. or Audrey W. Gunn Name

9-18-87 date By: Lewis Ret Davis Name Schles

9-21-87 date By: S.K. Graves Name

Affidavit rec'd: 8/24/87 date Checked by: BA P.P. time expires: 8/19/87 date

GW 369-A RESCINDED 08-23-1988 DE 88-C409

Report written: 7-28-88 Date Report sent: 8/23/88

DEVELOPMENT SCHEDULE

Beginning of Construction: Date sent \_\_\_\_\_ Date received \_\_\_\_\_  
Extensions: \_\_\_\_\_

Completion of Construction: Date sent \_\_\_\_\_ Date received \_\_\_\_\_  
Extensions: \_\_\_\_\_

Proof of Appropriation: Date sent \_\_\_\_\_ Date received \_\_\_\_\_  
Extensions: \_\_\_\_\_

Well report received: \_\_\_\_\_ date

DATE APPROVED FOR CHANGE: \_\_\_\_\_ BY: \_\_\_\_\_

- Superseding permit
- Superseding certificate
- Certificate of change (claims & adj. rights)  
Vol. 1-4, Page \_\_\_\_\_

ate certificate fees requested: \_\_\_\_\_ Date received: \_\_\_\_\_

ATE CHANGE ISSUED: \_\_\_\_\_

EMARKS: \_\_\_\_\_

file

BEFORE THE  
DEPARTMENT OF ECOLOGY  
STATE OF WASHINGTON

IN THE MATTER OF GROUND WATER )  
CERTIFICATE NO. 369-A TO )  
APPROPRIATE PUBLIC WATERS )

Rescinding Order  
Docket No. DE 88-C409

TO: City of Okanogan  
P.O. Box 752  
Okanogan, Washington 98840

On July 27, 1946, Certificate of Ground Water Right No. 369-A issued to the Town of Okanogan authorizing the withdrawal of 500 gallons per minute, 200 acre-feet per year for municipal supply. The authorized point of withdrawal was a well located in Lot 66, Alma Park Block, Kahlows Second Addition to Okanogan. The authorized place of use is the Town of Okanogan, Okanogan County, Washington.

In conjunction with an application for change filed by the City of Okanogan for this certificate, it was determined that only 350 gallons per minute has been withdrawn from the authorized well. The authorized 500 gallons per minute has not been put to beneficial use.

Certificate of Ground Water Right No. 369-A is hereby rescinded and a Superseding Certificate shall issue for 350 gallons per minute, 200 acre-feet per year for municipal supply.

DATED this 23<sup>rd</sup> day of August, 1988.

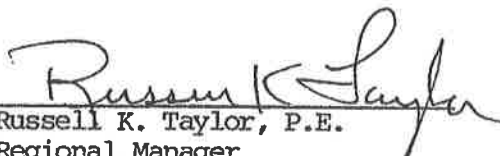
  
Russell K. Taylor, P.E.  
Regional Manager  
State of Washington  
Department of Ecology

ENGINEERING DATA

OK BJ

Application No. 321

CERTIFIED MAIL

BJ:ska  
811.rm8

file

State of Washington  
Department of Ecology  
Yakima, Washington

IN THE MATTER OF APPLICATION FOR CHANGE )  
BY THE CITY OF OKANOGAN TO CHANGE THE ) Findings of Fact  
POINT OF WITHDRAWAL UNDER GROUND WATER ) and Decision  
CERTIFICATE NO. 369-A )

Background

On July 20, 1987, the City of Okanogan filed an application to change the point of withdrawal authorized by Ground Water Certificate No. 369-A. The application was accepted and public notice was made. During the 30 day protest period, which ended on September 19, 1987, letters of protest were received from Philip and Audrey Gum, Lewis and Doris Jones, and Jack Graves. Their concerns will be addressed later in this report.

Investigation

A field inspection was conducted relative to this application on October 30, 1987. Additionally, a pump test was conducted on the proposed new point of withdrawal in July of 1987. The following information was obtained from the inspection, pump test, conversation with Ron Cook of Gray and Osborne, and conversations last year with Audrey Gum.

Ground Water Certificate No. 369-A, with a priority date of July 27, 1946, issued to the Town of Okanogan and authorized the withdrawal of 500 gallons per minute (gpm); 200 acre-feet per year from a well for municipal supply. The well is located in Lot 66, Alma Park Block of Kahlows Second Addition to Okanogan, approximately 100 feet south and 600 feet west of the east quarter corner of Section 17, T. 33 N., R. 26 E.W.M. It is located approximately 120 feet from the Okanogan River.

The city refers to this well as well No. 1 and it is 8 inches in diameter and was originally constructed to 90 feet. According to department records a 25 horsepower turbine pump was installed in the well. The well still has a 25 horsepower pump installed in it. Over the years the well has experienced problems with silting and sand. The capacity of the well has declined due to this. The city has no records to support how much water has been pumped from the well. Analysis of the pump and delivery system indicates that up to 350 gpm may have been pumped from the well when it was first developed. This year the city has only been able to pump about 150 gpm from the well.

The instant application requests authorization to change the point of withdrawal under Certificate No. 369-A to a new well the city constructed (well No. 5) in Lot 17 of Shirley Garden Tracts, being approximately 1250 feet north and 1650 feet east of the southwest corner of Section 17 in the SE1/4SW1/4 of Section 17, T. 33 N., R. 26 E.W.M. The proposed new point of withdrawal is located 4,000 feet south and slightly west of the currently authorized well.

The new well is 18 inches in diameter and 110 feet deep. It is located approximately 750 feet from the Okanogan River. The well penetrated sands and gravels with interbedded silts. A 50 horsepower turbine pump has been installed in the well. A pump test was conducted by Gray & Osborne with department staff monitoring. Department analysis of the pump test revealed that the aquifer penetrated by this well has an extremely high transmissivity, which allows for withdrawal of large quantities of water with little effect on water levels in neighboring wells. The well penetrates a water table aquifer that is recharged from the Okanogan River. The well is near the edge of an old flood channel, which contains water year-round. Following analysis of the aquifer characteristics, it was determined that over 80 percent of the water withdrawn from the well would be Okanogan river water if the well was pumped only 30 days. If the well was pumped the entire year almost 95 percent of the water would be from the river.

Ground Water Permit No. G4-29193P, with a January 30, 1987, priority date, has issued to the City of Okanogan authorizing the use of well No. 5. It authorizes the withdrawal of 650 gpm, 400 acre-feet per year for municipal supply. Due to the wells close proximity to the Okanogan River and the aquifer characteristics, the permit is subject to the minimum flows that have been adopted for the Okanogan River in the Okanogan River Basin Plan, Chapter 173-549 of the Revised Code of Washington (RCW). Well No. 5 is located in the southerly part of the city's service area, where water delivery has been difficult in the past. Construction

of well No. 5 has eliminated the problem and the city wants to be able to use well No. 5 to some extent all year. The well is currently able to pump up to 600 gpm and the city's plans do not include changing the pump. Permit No. G4-29193P will be reduced by the quantity of water that is authorized to be withdrawn from well No. 5 under Certificate No. 369-A, if the instant application for change is approved. The city has installed an hydraulic valve on the well that operates under variable pressure to allow for reducing the volume of water being pumped.

Besides Ground Water Certificate No. 369-A and Ground Water Permit No. G4-29193P, the city holds the following water rights:

1. Ground Water Certificate No. 266-D: 100 gpm, 29 acre-feet per year for municipal supply at Alma Park. The authorized well is located within the SE1/4NE1/4 of Section 17, T. 33 N., R. 26 E.W.M., approximately 100 feet from the Okanogan River. This dug well has been abandoned and an application for change has been filed to change the point of withdrawal to the city's well No. 1.
2. Ground Water Certificate No. 3410-A: 200 gpm, 320 acre-feet per year for municipal supply. The certificate issued supplemental to existing rights, meaning that the total annual water use would not exceed 320 acre-feet per year under all rights. The authorized well is within the SE1/4NW1/4 of Section 16, T. 33 N. R. 26 E.W.M. This drilled well is referred to as well No. 2. A 25 horsepower pump is installed in the well and 180 to 200 gpm is currently being withdrawn.
3. Ground Water Certificate No. 5327-A: 650 gpm, 700 acre-feet per year for municipal supply. The certificate issued supplemental to existing rights, meaning that the total annual water use would not exceed 700 acre-feet per year under all rights. The authorized well is located in Government Lot 2 of Section 9, T. 33 N., R. 26 E.W.M. This drilled well is referred to as well No. 3. A 75 horsepower pump is installed in the well and the authorized 650 gpm is currently being withdrawn.
4. Ground Water Certificate No. G4-23854C: 550 gpm, 400 acre-feet per year for municipal supply. The authorized well is located in the SE1/4NE1/4 of Section 17, T. 33 N., R. 26 E.W.M. This drilled well is referred to as well No. 4. A 100 horsepower pump is installed in the well and approximately 500 gpm is currently being withdrawn.
5. Water Right Claim No. 000052: Claims a right to divert 300 gpm, 484 acre-feet per year from springs (now called Watercress Springs) for municipal supply. The date of first water use on the claim is 1908. The springs are located in the SW1/4 of Section 5, T. 33 N., R. 26 E.W.M. The springs flow seasonally varies from 175 gpm to the claimed 300 gpm. The city uses these springs to the extent that water is available.

The water right claim was filed as a result of Chapter 90.14 RCW, which required filing a water right claim for any use that was initiated prior to adoption of the State Surface and Ground Water Codes. The Surface Water Code was adopted in June 1917 and the Ground Water Code was adopted in June 1945. The determination of the validity and extent of a water right claim can be made only through a Superior Court general adjudication.

#### Consideration of Objections

Philip and Audrey Gum own property and have two wells to the north and west of well No. 5. They indicate that in 1986 one of their wells almost went dry and the Gums and their neighbors do not think that the aquifer can stand the pressure of a withdrawal the size proposed by the city.

Mr. Gum is the holder of three certificates. Ground Water Declaration Certificate No. 1075, with a priority date of 1922, and Ground Water Certificate No. G4-26085C, with a priority date of January 10, 1979, are appurtenant to the Gum property. They issued on a dug well 48 inches in diameter and 20 feet deep. The well is located approximately 900 feet from city well No. 5. The well is located within the E1/2NW1/4SW1/4 of Section 17, T. 33 N., R. 26 E.W.M. It is used to irrigate 19 acres within that parcel. An additional five acres are irrigated in the W1/2NW1/4SW1/4 of Section 17 from the same well. Under the two



certificates, a maximum of 300 gpm, 120.5 acre-feet per year for the irrigation of 24 acres is authorized. This is the well that almost went dry last year and is Mr. Gum's primary concern. Last year the well was deepened to 50 feet. Mrs. Gum recently called and reported that her well has gone dry. They have a second well, which is authorized for use by Certificate No. G4-27385C, with a priority date of March 19, 1981. It is located over 1,000 feet from the city well. Mr. Gum's second well is six inches in diameter and 135 feet deep.

Besides the Gum certificates, there are three other ground water certificates which authorize water use from wells within half a mile of the city's new well. The wells authorized by these three certificates are between 25 and 48 feet deep and are constructed in the alluvial materials of the Okanogan River valley floor. There are several homes constructed in this area, but outside the city limits, that presumably receive their domestic water from wells constructed at their homes. Water right claims have been filed for several domestic wells in the area, however, there are no water well reports for these domestic wells.

The other two protestants, Jack Graves and Lewis Jones are the owners of two of the domestic wells in the area. Mr. Graves is concerned that if the city starts pumping 600 gpm from well No. 5, his domestic well will go dry. He states that his well has only six inches of water in it and until the last three years, he had plenty of water in it. Mr. Graves has two wells that he uses for domestic supply and lawn and garden irrigation. One is reportedly 30 feet deep and the other is 86 feet deep. Water Right Claims No. 036619, 036620, 122943, and 122944 were filed by Mr. Graves documenting his use of the wells. Mr. Jones letter of protest basically states the same concerns. Well reports are not available for Mr. Graves wells or Mr. Jones well. The Graves wells are located approximately 400 feet from well No. 5 and the Jones well is located approximately 600 feet from well No. 5.

Well reports for deeper wells constructed along the Okanogan River indicate that the alluvial material in the valley floor is rather extensive, extending several hundred feet below land surface. Infiltration from the river into this material provides the water table aquifer that is utilized by both the shallow domestic and irrigation wells and the new well constructed by the city. The sands and gravels into which the wells are constructed are permeable, allowing for migration of water through the materials. Given the aquifer characteristics determined through the pump test, we can determine that the water level in a well 150 feet from the city well would drop only three feet if the city well were pumped at 650 gpm for an entire year.

As previously stated, the aquifer which the existing shallow wells utilize is considerably more extensive than the 20 to 48 feet they currently penetrate. Deepening of the wells would more fully penetrate the aquifer and eliminate the affect of minor fluctuations of water level. During the past three years, the annual precipitation has been well below normal, causing low flows in many of the rivers and streams in Okanogan County, including the Okanogan River. It is very likely that the fluctuations in the water table observed by the protestants is the result of the lower flow in the Okanogan River, and not the result of an over-allocated aquifer. Data collected by the department for wells adjacent to the Okanogan River indicates that they demonstrate regular cycles in water levels and that they are recharged annually by the spring freshet.

The Ground Water Code, Chapter 90.44 RCW, does provide that the prior appropriator shall as against subsequent appropriators from the same ground water body be entitled to the preferred use of such ground water to the extent of his appropriation and beneficial use, and shall enjoy the right to have any withdrawals by a subsequent appropriator of ground water limited to an amount that will maintain and provide a safe sustaining yield in the amount of prior appropriation. This does not mean that the prior appropriator is guaranteed his right to continue using a shallow well that has barely penetrated the aquifer. If he can obtain a safe sustaining yield in the amount of his prior appropriation by deepening the well, but still being within the same aquifer, subsequent appropriators would not be limited.

Section 90.44.100 RCW provides that the holder of a valid right to withdraw public ground waters may, without losing his priority of right, construct wells or other means of withdrawal at a new location in substitution for or in addition to those

at the original location provided that that substitute well taps the same body of public ground water as the original well, use of the original well is discontinued, the construction of the substitute well will not enlarge the right conveyed by the original certificate and other existing rights will not be impaired.

Conclusions

Based on the foregoing information, the following conclusions are made:

The City of Okanogan has a valid water right under Ground Water Certificate No. 369-A. However, it appears that the right was only perfected to the instantaneous quantity of 350 gpm, not the 500 gpm stated on the face of the, <sup>30</sup> certificate. The certificate shall be rescinded and reissued for the ~~250~~ <sup>30</sup> gpm that was actually developed when the certificate issued. Well No. 5 penetrates the same aquifer as well No. 1, and although the well will produce in excess of 350 gpm, since the city already has a permit for the quantity above <sup>30</sup>250 gpm, the change will not enlarge the right. Due to the characteristics of the aquifer penetrated by well No. 5, the proposed change will not impair existing rights.

Recommendations

It is recommended that Ground Water Certificate No. 369-A be rescinded and reissued for the reduced quantity of 350 gallons per minute, 200 acre-feet per year. The authorized point of withdrawal will be a well located approximately 1700 feet east and 1200 feet north of the southwest corner of Section 17, being within the SE1/4SW1/4 of Section 17, T. 33 N., R. 26 E.W.M.

Ground Water Permit No. G4-29193P shall be reduced to 300 gpm upon issuance of the certificate of change under this authorization. During periods of regulation on Ground Water Permit No. G4-29193P the city shall reduce their withdrawal from well No. 5 to 350 gpm.

All water wells constructed within the state shall meet the minimum standards for construction and maintenance as provided under RCW 18.104 (Washington Water Well Construction Act of 1971) and Chapter 173-160 WAC (Minimum Standards for Construction and Maintenance of Water Wells).

Installation and maintenance of an access port as described in Ground Water Bulletin No. 1 is required. An air line and gage may be installed in addition to the access port.

REPORT BY:

Becky Johnson  
Becky Johnson

DATE:

8/23/88

APPROVED BY:

Doug Clausen  
Doug Clausen, Regional Supervisor

DATE:

8/23/1988

82mm8  
ska



CG4-GWC266-D

BEFORE THE POLLUTION CONTROL HEARINGS BOARD  
OF THE STATE OF WASHINGTON

JACK & ORVILLA GRAVES, LEWIS R. )  
JONES, and PHILIP & AUDREY GUM, )

Appellants, )

v. )

STATE OF WASHINGTON, DEPARTMENT )  
OF ECOLOGY and CITY OF )  
OKANOGAN, )

Respondents. )

PCHB Nos. 88-140, 141 & 144

ORDER AMENDING FINDINGS OF FACT,  
CONCLUSIONS OF LAW AND ORDER

On April 20, 1989, the Board entered its Final Findings of Fact,  
Conclusions of Law and Order.

Subsequently, counsel for respondent Department of Ecology, sought  
clarification of the standard applied to transfers of the point of  
groundwater withdrawal.

The clarification sought would change neither the reasoning or  
result of the decision. Moreover it does not appear to prejudice any  
party that such a clarification be made.

Therefore the Board sua sponte amends its decision by addition of  
the clarification at p. 6, lines 4 to 23. The attached Amended  
Findings, Conclusions and Order reflect this clarification.

DONE at Lacey, WA, this 10<sup>th</sup> day of May, 1989.

POLLUTION CONTROL HEARINGS BOARD

Wick Dufford  
WICK DUFFORD, Chairman

Judith A. Bendor  
JUDITH A. BENDOR, Member

William A. Harrison  
WILLIAM A. HARRISON  
Administrative Appeals Judge

1  
2  
3  
4  
5  
6  
7  
8  
9  
10  
11  
12  
13  
14  
15  
16  
17  
18  
19  
20  
21  
22  
23  
24  
25  
26  
27

FINDINGS OF FACT

I

This matter concerns allegations by senior appropriators of ground water that changes in the point of withdrawal granted by Department of Ecology (DOE) to the City of Okanogan would result in impairment of their rights of appropriation.

II

The City of Okanogan (City) is located generally on a north-south axis alongside the Okanogan River. Although the City maintains a municipal water supply system, the system has fallen short with regard to the south end of the City. During certain times of the year the City's water system has not provided the south end with enough water for all domestic purposes, and also has not provided sufficient pressure for fire protection.

III

In order to address these chronic water problems in the south end, the City developed a Comprehensive Water System Improvement Plan. The plan called for development of a new well (known as City No. 5) in the south end of the City. City No. 5 is 94 feet deep and draws its waters (650 gallons per minute) from an underground aquifer which is in hydraulic continuity with the surface waters of the Okanogan River. Therefore, in approving City No. 5, DOE required summertime curtailment of pumping when the River reaches its administrative minimum flow.



1  
2  
3  
4  
5  
6  
7  
8  
9  
10  
11  
12  
13  
14  
15  
16  
17  
18  
19  
20  
21  
22  
23  
24  
25  
26  
27

IV

In recognition of the summertime curtailment of pumping in City No. 5, and consistent with its Comprehensive Water System Improvement Plan, the City proposed to transfer to City No. 5 the City's existing water right (350 gallons per minute) from a north end well known as City No. 1. That existing right drew its waters from the same riverside aquifer as City No. 5. However, this existing City right is not subject to summertime curtailment in respect of administrative minimum flows in the River, since that right was prior in time to those minimum flows.

V

In June, 1987, DOE tested City No. 5 using generally accepted practices, including three observation wells. From such testing, the characteristics of the aquifer in question were determined. Those characteristics are not dependent upon the time of year in which the pump tests occurred. The DOE then used the aquifer characteristics (specific yield and transmissivity), pumping rates and duration of pumping to determine hypothetical cones of influence caused by pumping City No. 5. Using a withdrawal rate of 600 gallons per minute, the pumping of City No. 5 was determined by DOE to result in the following drawdowns of water level at the following radii from the well:

1  
2  
3  
4  
5  
6  
7  
8  
9  
10  
11  
12  
13  
14  
15  
16  
17  
18  
19  
20  
21  
22  
23  
24  
25  
26  
27

<u>RADIUS</u>	<u>DRAWDOWN</u>
50 feet	3.9 ft.
100 feet	3.3 ft.
200 feet	2.8 ft.
300 feet	2.5 ft.
500 feet	2.19 ft
1000 feet	1.7 ft

VI

Errors concerning the distance between City No. 5 and the test wells were made by DOE, but were not significant in assessing the drawdown effect set forth above.

VII

In August, 1988, DOE approved the transfer of existing rights at City No. 1 to City No. 5 (350 gallons per minute, Ground Water Certificate 369-A). In September, 1988, DOE also approved transfer of City water rights in another north end well to City No. 1 (100 gallons per minute, Ground Water Certificate No. 266-D).

VIII

During August, 1988, the City pumped from City No. 5 under the rights transferred there from City No. 1 (without the curtailment in respect to minimum flows to which the transferred right was not subject). We summarize the experiences of senior appropriators during August, 1988 as follows:

1. Lewis Jones - domestic water right. Mr. Jones' 20 foot well in the basement of his home went dry. He drove a sand point six feet into the bottom of his well. This provided the needed water for household use.

1 2. Jack Graves - domestic water right. Mr.  
2 Graves' 30 foot well, used for lawn watering, went  
3 dry. He used a seven foot pipe to recover water  
4 in the well.

5 3. Mildred Goff - domestic water right. Mrs.  
6 Goff's 20 foot well sustained a drop in water  
7 level of five to six feet. This left water in the  
8 well, but below the foot-valve of her pump system.

9 4. Dorothy Archer - domestic water right. Mrs.  
10 Archer's 20 foot well used for lawn watering  
11 sustained a drop in water level below the  
12 foot-valve but did have water in the well.

13 5. Geraldine Pickett - domestic water right.  
14 Mrs. Pickett's 25 foot well used for home and  
15 garden sustained a drop in water level below the  
16 foot-valve, leaving water in the well.

17 6. Phillip Gum - irrigation water right. Mr.  
18 Gum's 27 foot well is used to irrigate 32 acres of  
19 orchard. This well went dry. Mr. Gum has  
20 obtained an estimate in the amount of \$12,468 from  
21 a well driller to drill a new 90-foot well and  
22 install a new pump to provide a constant supply of  
23 water.

24 All of the wells described above have been in operation for 30  
25 years or more. None has previously gone dry in the summer. The  
26 lowering of water levels described above was caused by withdrawals at  
27 City No. 5 pursuant to the right transferred there from City No. 1.  
28 The actual drawdown attributable to City No. 5 was in the range of 2 -  
29 4 feet.

30 IX

31 Mssrs. Graves, Jones and Gum appeal DOE's approval of the water  
32 right transfers for the City of Okanogan.

33 X

34 Any Conclusion of Law deemed to be a Finding of Fact is hereby  
35 AMENDED FINAL FINDINGS OF FACT,  
36 CONCLUSIONS OF LAW AND ORDER

37 PCHB No. 88-140, 141, & 144 (5)

1 adopted as such. From these Findings of Fact, the Board makes these

2 CONCLUSIONS OF LAW

3 I

4 Changes of point of withdrawal and place of use for groundwater  
5 rights are explicitly governed by RCW 90.44.100. The primary  
6 limitations on such transfers are: (1) the new withdrawal must be  
7 from the same aquifer; (2) the original right may not be enlarged; (3)  
8 existing rights shall not be impaired.

9 Here the first two of these propositions are not seriously  
10 questioned. The focus is on the third -- impairment of existing  
11 rights. We believe that this standard in the transfer context must be  
12 broadly construed, consistent with the statutory concerns for  
13 comprehensive state administration of water allocation expressed in  
14 Chapter 90.03, 90.44 and 90.54 RCW, read as a whole.

15 We do not believe the Legislature intended for a right to be  
16 moved to a new location where a right could not have been created  
17 originally. Thus, we conclude that such transfers must conform with  
18 the water availability, beneficial use and public interest criteria  
19 which apply to the granting of new rights. RCW 90.03.290; See Schuh  
20 v. Department of Ecology, 100 Wn.2d 180, 667 P.2d 64 (1983). In  
21 short, the only thing different about moving a right from creating a  
22 right is that in the former case the priority pre-dates the  
23 application.

24  
25  
26 AMENDED FINAL FINDINGS OF FACT,  
CONCLUSIONS OF LAW AND ORDER

27 PCHB No. 88-140, 141, & 144 (6)

1  
2  
3  
4  
5  
6  
7  
8  
9  
10  
11  
12  
13  
14  
15  
16  
17  
18  
19  
20  
21  
22  
23  
24  
25  
26  
27

II

With regard to the water right transferred from City No. 1 to City No. 5 (350 gallons per minute, Certificate 369-A), appellants question neither the availability of water nor that the City's use for it is beneficial. We conclude that water is available and the City's use is beneficial and perhaps imperative. The challenged transfer is consistent with RCW 90.03.290, as applied to groundwater by RCW 90.44.060, in so far as availability of water and beneficial use are concerned.

III

Appellants do challenge the consistency of the transfer, from City No. 1 to City No. 5, with the two additional requirements of RCW 90.03.290 that (1) there be no impairment of existing rights and (2) that there be no detriment to the public welfare. In considering these we must also consider RCW 90.44.070 which provides:

No permit shall be granted for the development or withdrawal of public ground waters beyond the capacity of the underground bed or formation in a given basin, district, or locality to yield such water within a reasonable or feasible pumping lift in case of pumping developments.

and RCW 90.44.130 which provides:

As between appropriators of public ground water, the prior appropriator shall as against subsequent appropriators from the same ground water body be entitled to the preferred use of such ground water to the extent of his appropriation and beneficial use, and shall enjoy the right to have any withdrawals by a subsequent appropriator of ground water limited to an amount

AMENDED FINAL FINDINGS OF FACT,  
CONCLUSIONS OF LAW AND ORDER

PCHB No. 88-140, 141, & 144

(7)





V

1  
2 Upon the totality of the evidence before us we cannot conclude  
3 that the City's right impairs existing water rights. From the DOE  
4 estimates and actual experience of the appellants and others it  
5 appears that the drawdown effect of City No. 5 would not cause  
6 existing appropriators to deepen their wells beyond a reasonable or  
7 feasible pumping lift. The transfer from City No. 1 to City No. 5 of  
8 a water right for 350 gallons per minute (Certificate 369-A) should  
9 therefore be affirmed.

10 VI

11 There is need in this case for a determination of what the  
12 reasonable or feasible pumping lift is, for domestic and irrigation  
13 use, in this locality to serve as a guide for the future relationship  
14 of the parties and subsequent well developers. We have held that RCW  
15 90.44.070 requires DOE to determine a range within which pumping lifts  
16 would be reasonable for domestic pumping developments before issuing a  
17 ground water permit which could affect a prior water right. Heer  
18 Brothers, supra, p. 8. In this case, however, we are persuaded that  
19 the instant municipal development will not place appellants close to  
20 the limit of such a range. Therefore, a condition should be added to  
21 DOE's approval of the transfer (Certificate 369-A) requiring that:

22 This approval shall be subject to  
23 permittee's submitting evidence sufficient for  
24 DOE's determination of reasonable or feasible  
25 pumping lifts for existing domestic and irrigation

26 AMENDED FINAL FINDINGS OF FACT,  
27 CONCLUSIONS OF LAW AND ORDER

PCES No. 88-140, 141, & 144

1 rights. Such a determination shall be made for  
2 the locality concerned by the issuance of a  
3 regulatory order within a reasonable time after  
4 this approval.

5 We conclude that such a condition and determination by DOE would  
6 establish with necessary clarity the line between the rights of senior  
7 and junior appropriators in the locality in question, and that such a  
8 condition is required to conform this approval with RCW 90.44.070 and  
9 the public welfare clause of RCW 90.03.290. Such a determination  
10 should be made by reference to the criteria of DOE's rule regarding  
11 reasonable or feasible pumping lift, WAC 173-150-040.

12 VII

13 Any Finding of Fact deemed to be a Conclusion of Law is hereby  
14 adopted as such. From these Conclusions of Law, the Board enters this  
15  
16  
17  
18  
19  
20  
21  
22  
23  
24  
25

ORDER

The transfer of water right to City well No. 1 (Certificate 266-D) is hereby affirmed. The transfer of water right to City well No. 5 is hereby remanded for addition of the condition set out in Conclusion of Law VI, above, but is in all other respects affirmed.

DONE at Lacey, Washington, this 10<sup>th</sup> day of May, 1989.

POLLUTION CONTROL HEARINGS BOARD

Wick Dufford  
WICK DUFFORD, Chairman

Judith A. Bendor  
JUDITH A. BENDOR, Member

William A. Harrison  
WILLIAM A. HARRISON  
Administrative Appeals Judge

AMENDED FINAL FINDINGS OF FACT,  
CONCLUSIONS OF LAW AND ORDER

PCHB No. 88-140, 141, & 144

(11)

*file*

State of Washington  
Department of Ecology  
Yakima, Washington

IN THE MATTER OF APPLICATION FOR CHANGE )  
BY CITY OF OKANOGAN TO CHANGE THE POINT ) Findings of Fact  
OF WITHDRAWAL AND CHANGE THE PURPOSE ) and Decision  
AND PLACE OF USE UNDER GROUND WATER )  
CERTIFICATE NO. 266-D )

Background

On July 20, 1987, the City of Okanogan filed an application to change the point of withdrawal authorized by Ground Water Certificate No. 266-D. The application was accepted and public notice was made. During the 30 day protest period, which ended on September 19, 1987, letters of protest were received from Philip and Audrey Gum, Lewis and Doris Jones, and Jack Graves. Their concerns will be addressed later in this report.

Investigation

A field inspection was conducted relative to this application on October 30, 1987. The following information was obtained from the inspection, conversation with Ron Cook of Gray and Osborne, and conversations last year with Audrey Gum.

Ground Water Certificate No. 266-D issued to the Town of Okanogan and authorized the withdrawal of 100 gallons per minute (gpm); 29 acre-feet per year from a well for municipal swimming pool and park irrigation. The authorized place of use is Alma Park, Town of Okanogan, Washington. The authorized well location is in Alma Park, Tax Lot 66, Town of Okanogan. It was located approximately 300 feet west and 100 feet north of the east quarter corner of Section 17, being within the SE1/4NE1/4 of Section 17, T. 33 N., R. 26 E.W.M.

The well was constructed in the 1920's. It was reportedly a dug well approximately 25 feet deep. The well was located about 50 feet from the Okanogan River. In the late 1960's or early 1970's the well was abandoned and water delivery to the park was continued from the municipal system. The instant application requests after the fact authorization to change the point of withdrawal to the city's well No. 1, which is located about 50 feet west of the well authorized by the certificate. Well No. 1 is part of the municipal system. It is 12 inches in diameter and was originally constructed to 110 feet. The well has reportedly had problems with sand and silt and may not be that deep at this time. A 25 horsepower pump is installed in the well. The city intends to replace the pump this fall and if this application for change is approved will install a pump that is capable of withdrawing 100 gpm. Ground Water Certificate No. 369-A issued on well No. 1. The department has recently approved an application for change to move this certificate to the newly constructed well No. 5.

The instant application requests authorization to change the purpose of use to municipal supply since supplying water for the park is generally considered a municipal water use and water that is delivered to the park is through the municipal system. The applicant also wants to change the place of use to the City of Okanogan, again because water from well No. 1 is pumped into the municipal system for distribution. Since water was originally only used for the park and swimming pool, the well was pumped only during irrigation season.

Section 90.44.100 of the Revised Code of Washington (RCW) provides that the holder of a valid right to withdraw public ground waters may, without losing his priority of right, construct wells or other means of withdrawal at a new location in substitution for or in addition to those at the original location provided that the substitute well withdraws from the same body of public ground water as the original well, use of the original well is discontinued, the construction of the substitute well will not enlarge the right conveyed by the original certificate and other existing rights will not be impaired. If the season of use remains the normal irrigation season of April 1 to October 31, there will be no enlargement of the right.

Chapter 90.14 RCW provides that a right that goes unused for five or more consecutive years relinquishes to the state due to nonuse. Section 90.14.140 provides, however, that there is no relinquishment if the use claimed is municipal supply. A further consideration is whether the use has in fact been ongoing but from a different point of withdrawal.

Consideration of Objections

All of the protestants express the same concern. They fear that the proposed change in point of withdrawal will affect their wells. The protestants' property and wells lie in the S1/2SW1/4 of Section 17 approximately 4,000 feet from the city's well No. 1, which is the proposed point of withdrawal. The protestants appear to mistakenly believe that the instant application for change seeks authorization to change the point of withdrawal to the city's well No. 5, which is located in the SE1/4SE1/4 of Section 17, within 1,000 feet or less of each of their wells. This is not the case.

Conclusions

Based on the foregoing information, the following conclusions are made:

The proposed change in point of withdrawal will not impair existing rights due to the close proximity of the originally authorized well to the proposed new well and the extensive nature of the aquifer being utilized. The proposed change in purpose of use and place of use does not represent an enhancement since the city is still restricted to withdrawing only 100 gpm, 29 acre-feet per year from the well and the use originally authorized is normally considered municipal supply. It will however, be necessary to restrict the period of use to the season normally required for park and swimming pool uses or from April 1 through October 31 each year. Use of the well during the winter will have to be under a separate authorization.

Recommendations

It is recommended that a superseding certificate issue authorizing the withdrawal of 100 gallons per minute, 29 acre-feet per year for municipal supply from April 1 to October 31 within the City of Okanogan. The authorized point of withdrawal will be a well located approximately 100 feet north and 350 feet west of the east quarter corner of Section 17, being within the SE1/4NE1/4 of Section 17, T. 33 N., R. 26 E.W.M.

All water wells constructed within the state shall meet the minimum standards for construction and maintenance as provided under RCW 18.104 (Washington Water Well Construction Act of 1971) and Chapter 173-160 WAC (Minimum Standards for Construction and Maintenance of Water Wells).

Installation and maintenance of an access port as described in Ground Water Bulletin No. 1 is required. An air line and gage may be installed in addition to the access port.

REPORT BY:

Becky Johnson  
Becky Johnson

DATE:

9/6/88

APPROVED BY:

Doug Clausing  
Doug Clausing, Regional Supervisor

DATE:

9/6/1988

Green

State of Washington  
Department of Ecology  
Yakima, Washington

IN THE MATTER OF APPLICATION FOR CHANGE )  
BY CITY OF OKANOGAN TO CHANGE THE POINT ) Findings of Fact  
OF WITHDRAWAL AND CHANGE THE PURPOSE ) and Decision  
AND PLACE OF USE UNDER GROUND WATER )  
CERTIFICATE NO. 266-D )

Background

On July 20, 1987, the City of Okanogan filed an application to change the point of withdrawal authorized by Ground Water Certificate No. 266-D. The application was accepted and public notice was made. During the 30 day protest period, which ended on September 19, 1987, letters of protest were received from Philip and Audrey Gum, Lewis and Doris Jones, and Jack Graves. Their concerns will be addressed later in this report.

Investigation

A field inspection was conducted relative to this application on October 30, 1987. The following information was obtained from the inspection, conversation with Ron Cook of Gray and Osborne, and conversations last year with Audrey Gum.

Ground Water Certificate No. 266-D issued to the Town of Okanogan and authorized the withdrawal of 100 gallons per minute (gpm); 29 acre-feet per year from a well for municipal swimming pool and park irrigation. The authorized place of use is Alma Park, Town of Okanogan, Washington. The authorized well location is in Alma Park, Tax Lot 66, Town of Okanogan. It was located approximately 300 feet west and 100 feet north of the east quarter corner of Section 17, being within the SE1/4NE1/4 of Section 17, T. 33 N., R. 26 E.W.M.

The well was constructed in the 1920's. It was reportedly a dug well approximately 25 feet deep. The well was located about 50 feet from the Okanogan River. In the late 1960's or early 1970's the well was abandoned and water delivery to the park was continued from the municipal system. The instant application requests after the fact authorization to change the point of withdrawal to the city's well No. 1, which is located about 50 feet west of the well authorized by the certificate. Well No. 1 is part of the municipal system. It is 12 inches in diameter and was originally constructed to 110 feet. The well has reportedly had problems with sand and silt and may not be that deep at this time. A 25 horsepower pump is installed in the well. The city intends to replace the pump this fall and if this application for change is approved will install a pump that is capable of withdrawing 100 gpm. Ground Water Certificate No. 369-A issued on well No. 1. The department has recently approved an application for change to move this certificate to the newly constructed well No. 5.

The instant application requests authorization to change the purpose of use to municipal supply since supplying water for the park is generally considered a municipal water use and water that is delivered to the park is through the municipal system. The applicant also wants to change the place of use to the City of Okanogan, again because water from well No. 1 is pumped into the municipal system for distribution. Since water was originally only used for the park and swimming pool, the well was pumped only during irrigation season.

Section 90.44.100 of the Revised Code of Washington (RCW) provides that the holder of a valid right to withdraw public ground waters may, without losing his priority of right, construct wells or other means of withdrawal at a new location in substitution for or in addition to those at the original location provided that the substitute well withdraws from the same body of public ground water as the original well, use of the original well is discontinued, the construction of the substitute well will not enlarge the right conveyed by the original certificate and other existing rights will not be impaired. If the season of use remains the normal irrigation season of April 1 to October 31, there will be no enlargement of the right.



Chapter 90.14 RCW provides that a right that goes unused for five or more consecutive years relinquishes to the state due to nonuse. Section 90.14.140 provides, however, that there is no relinquishment if the use claimed is municipal supply. A further consideration is whether the use has in fact been ongoing but from a different point of withdrawal.

Consideration of Objections

All of the protestants express the same concern. They fear that the proposed change in point of withdrawal will affect their wells. The protestants' property and wells lie in the S1/2SW1/4 of Section 17 approximately 4,000 feet from the city's well No. 1, which is the proposed point of withdrawal. The protestants appear to mistakenly believe that the instant application for change seeks authorization to change the point of withdrawal to the city's well No. 5, which is located in the SE1/4SE1/4 of Section 17, within 1,000 feet or less of each of their wells. This is not the case.

Conclusions

Based on the foregoing information, the following conclusions are made:

The proposed change in point of withdrawal will not impair existing rights due to the close proximity of the originally authorized well to the proposed new well and the extensive nature of the aquifer being utilized. The proposed change in purpose of use and place of use does not represent an enhancement since the city is still restricted to withdrawing only 100 gpm, 29 acre-feet per year from the well and the use originally authorized is normally considered municipal supply. It will however, be necessary to restrict the period of use to the season normally required for park and swimming pool uses or from April 1 through October 31 each year. Use of the well during the winter will have to be under a separate authorization.

Recommendations

It is recommended that a superseding certificate issue authorizing the withdrawal of 100 gallons per minute, 29 acre-feet per year for municipal supply from April 1 to October 31 within the City of Okanogan. The authorized point of withdrawal will be a well located approximately 100 feet north and 350 feet west of the east quarter corner of Section 17, being within the SE1/4NE1/4 of Section 17, T. 33 N., R. 26 E.W.M.

All water wells constructed within the state shall meet the minimum standards for construction and maintenance as provided under RCW 18.104 (Washington Water Well Construction Act of 1971) and Chapter 173-160 WAC (Minimum Standards for Construction and Maintenance of Water Wells).

Installation and maintenance of an access port as described in Ground Water Bulletin No. 1 is required. An air line and gage may be installed in addition to the access port.

REPORT BY:

Becky Johnson  
Becky Johnson

DATE:

9/6/88

APPROVED BY:

Doug Clausing  
Doug Clausing, Regional Supervisor

DATE:

9/6/1988

CG4 – 23854C



STATE OF WASHINGTON  
DEPARTMENT OF ECOLOGY

15 West Yakima Avenue, Suite 200 • Yakima, Washington 98902-3452 • (509) 575-2490

August 17, 2006  
CERTIFIED MAIL

City of Okanogan  
PO Box 752  
Okanogan WA 98840-0752

**RE: Application for Temporary Change Authorization No. CG4-23854C**

On August 9, 2006, Change Application No. for G4-23854C was submitted to the Department of Ecology (Ecology). The application was accepted and assigned Ground Water Change No. CG4-23854C. The City of Okanogan (Okanogan/City) is seeking a Temporary Change Authorization to establish a second point of withdrawal under Water Right No. G4-23854C, with a priority date of December 24, 1975. The water will be used for municipal supply as authorized under the original Certificate.

Certificate No. G4-23854C authorizes water withdrawal from Well No. 4. Okanogan is temporarily suspending use of Well No. 4 to make improvements needed to satisfy new EPA arsenic standards. The temporary suspension leaves Okanogan with a significant deficit in their sources available to meet water supply needs for the City.

The temporary change request is to allow use of Well No. 5 as an additional point of withdrawal for the period while Well No. 4 is removed from service, to get the City through the impending low flow period for the 2006/2007 period.

Well No. 5 has two water rights associated with it:

1. The first is GWC 369-A. It authorizes withdrawal from the well at an instantaneous rate of 350 gallons per minute, 200 acre-feet per year, for municipal supply.
2. The second water right is G4-29193P which authorizes withdrawal from the well at an instantaneous rate of 650 gpm, 400 acre-feet per year, for municipal supply. The 400 acre feet per year allocation, including foreseeable growth, was the recognized total of all the City's rights in existence when this permit issued. The water right is interruptible whenever the flow of the Okanogan River falls below the minimum flows as set by Chapter 173-549 WAC. WAC 173-549, the Okanogan River Basin Plan, established minimum instream flows in the Okanogan and Similkameen Rivers as well as seasonally closing all tributary perennial streams to further consumptive appropriation and establishing guidelines for further appropriation from lakes and ponds.

**FILE COPY**



- Well No. 4 is located 450 feet north and 375 feet west from the east quarter corner of section 17, being within the SE $\frac{1}{4}$ NE $\frac{1}{4}$  of Section 17, T. 33 N., R. 26 E.W.M. It is 525 feet west of the Okanogan River.
- Well No. 5 is located 1250 feet north and 1650 feet east of the southwest corner of Section 17, being within the SE $\frac{1}{4}$ SW $\frac{1}{4}$  of Section 17, T. 33N., R. 26 E.W.M. Well No. 5. It is 875 feet west of the Okanogan River and 3700 feet southwest from Well No. 4.

Okanogan wishes to continue withdrawal from Well No. 5 at a rate not to exceed 650 gallons per minute. That amount is equal to the existing 350 gpm authorized under GWC 369-A and an additional 300 gallons per minute of the instantaneous rate authorized for withdrawal from Well No. 4 under G4-23854C.

**Conclusion:**

1. Since the requested authorization from Well No. 5 is less than the authorized rate when the level of the Okanogan River is above the established minimum flow, there will be no impairment of existing rights.
2. Withdrawal from the well is limited to a total of 650 gallons per minute of non-interruptible instantaneous rate.
3. The short term change in source is processed prior to competing applications because it is determined that immediate action is necessary to maintain options for the highest quality potable water supply for the patrons of the City water system (WAC 173-152-050 (2)(a)).
4. This Temporary Change Authorization is granted in accordance with RCW 90.03.390.

**Provisions:**

No well construction or well modification is anticipated with this temporary authorization.

**The operator of the system under this authorization shall:**

- Have a copy of this Temporary Change Authorization at or near the wells when pumping water;
- Provide said copy as evidence of this authorization upon request by Department of Ecology or Department of Fish and Wildlife staff;
- Be aware of the parameters and provisions and operate accordingly;
- An up to date record of water use for this project shall be maintained.
- The second source of water for Ground Water Certificate G4-23854C is a well (Well No. 5), located 1250 feet north and 1650 feet east of the southwest corner of Section 17, being within the SE $\frac{1}{4}$ SW $\frac{1}{4}$  of Section 17, T. 33 N., R. 26 E.W.M.
- Withdrawal from Well No. 5 under this authorization is limited to a total of 650 gallons per minute (at a non-interruptible rate). The total annual quantity from all sources shall not exceed 400 acre-feet per year.

Y400 2006

City of Okanogan  
Temporary Change Authorization  
CG4-23854C  
August 17, 2006

**Withdrawal of water under this temporary authorization may take place for one year, from August 7, 2006, to August 1, 2007.**

This authorization shall in no way excuse the permittee from compliance with any applicable federal, state, or local statutes, ordinances, or regulations including those administered by other programs of the Department of Ecology and those administered by local and state health departments for public water supplies.

An approved measuring device shall be installed and maintained for each of the sources identified by this water right in accordance with the rule "Requirements for Measuring and Reporting Water Use", Chapter 173-173 WAC.

Water use data shall be recorded daily. The recorded daily records, the maximum monthly rate of withdrawal and the monthly total volume shall be submitted to Ecology by January 1, 2007 and August 31, 2007. Ecology is requiring recording of daily meter readings to collect seasonal information for water resource planning, management and compliance.

The following information shall be included with each submittal of water use data: owner, contact name if different, mailing address, daytime phone number, WRIA 49, all certificate and permit numbers including TEMPORARY Change no. CG4-23854C, source name, annual quantity used including units of measurement, maximum rate of withdrawal, *monthly meter readings including units of measurement, peak monthly flow including units of measurement, Department of Health WFI water system number and source number(s), purpose of use, well tag number,* and period of use. Ecology prefers web based data entry, but does accept hard copies. Ecology will provide forms and electronic data entry information.

Chapter 173-173 WAC describes the requirements for data accuracy, device installation and operation, and information reporting. It also allows a water user to petition Ecology for modifications to some of the requirements. Installation, operation and maintenance requirements are enclosed as a document entitled "Water Measurement Device Installation and Operation Requirements".

Department of Ecology personnel, upon presentation of proper credentials, shall have access at reasonable times, to the records of water use that are kept to meet the above conditions, and to inspect at reasonable times any measuring device used to meet the above conditions.

You have the right to appeal this decision to the Pollution Control Hearings Board. Pursuant to Chapter 43.21B RCW, your appeal must be filed with the Pollution Control Hearings Board, and served on the Department of Ecology, within thirty (30) days of the date of your receipt of this document.

To appeal this decision, your notice of appeal must contain a copy of the Ecology decision you are appealing.

City of Okanogan  
Temporary Change Authorization  
CG4-23854C  
August 17, 2006

Your appeal must be filed with:

The Pollution Control Hearings Board  
4224 - 6th Avenue SE Rowe Six Bldg 2  
PO Box 40903  
Lacey WA 98504-0903

Your appeal must also be served on:

The Department of Ecology  
Appeals Coordinator  
PO Box 47608  
Olympia WA 98504-7608

In addition, please send a copy of your appeal to:

G. Thomas Tebb, L.E.G.  
Department of Ecology  
15 W Yakima Ave Ste 200  
Yakima WA 98902-3452

Sincerely,

 For

G. Thomas Tebb, L.E.G.  
Section Manager  
Water Resources Program

MS:CM:gg  
060821

Enclosure: Water Measurement Device Installation and Operation Requirements  
Your Right To Be Heard

cc: Philip Rigdon, Deputy Director, Natural Resources Division, Yakama Nation



G4 – 29193

*file*

STATE OF WASHINGTON  
DEPARTMENT OF ECOLOGY

**REPORT OF EXAMINATION  
TO APPROPRIATE PUBLIC WATERS OF THE STATE OF WASHINGTON**

- Surface Water (Issued in accordance with the provisions of Chapter 117, Laws of Washington for 1917, and amendments thereto, and the rules and regulations of the Department of Ecology.)
- Ground Water (Issued in accordance with the provisions of Chapter 263, Laws of Washington for 1945, and amendments thereto, and the rules and regulations of the Department of Ecology.)

PRIORITY DATE January 30, 1987	APPLICATION NUMBER G4-29193	PERMIT NUMBER	CERTIFICATE NUMBER
-----------------------------------	--------------------------------	---------------	--------------------

NAME City of Okanogan			
ADDRESS (STREET) P.O. Box 752	(CITY) Okanogan,	(STATE) Washington	(ZIP CODE) 98840

**PUBLIC WATERS TO BE APPROPRIATED**

SOURCE A well (Well No. 5)		
TRIBUTARY OF (IF SURFACE WATERS)		

MAXIMUM CUBIC FEET PER SECOND	MAXIMUM GALLONS PER MINUTE 650	MAXIMUM ACRE-FEET PER YEAR 400
-------------------------------	-----------------------------------	-----------------------------------

QUANTITY, TYPE OF USE, PERIOD OF USE  
To be used continuously for municipal supply.

**LOCATION OF DIVERSION/WITHDRAWAL**

APPROXIMATE LOCATION OF DIVERSION—WITHDRAWAL  
1250 feet north and 1650 feet east of the southwest corner of Section 17

LOCATED WITHIN (SMALLEST LEGAL SUBDIVISION) SE 1/4 SW 1/4	SECTION 17	TOWNSHIP N. 33	RANGE, (E. OR W.) W.M. 26 E	W.R.I.A. 49	COUNTY Okanogan
--	---------------	-------------------	--------------------------------	----------------	--------------------

**RECORDED, PLATTED PROPERTY**

LOT 17	BLOCK	OF (GIVE NAME OF PLAT OR ADDITION) Shirley Garden Tracts
-----------	-------	---

**LEGAL DESCRIPTION OF PROPERTY ON WHICH WATER IS TO BE USED**

City of Okanogan municipal service area

---

DESCRIPTION OF PROPOSED WORKS

---

An 18-inch diameter well 110 feet deep. Pump size to be determined.

---

DEVELOPMENT SCHEDULE

---

BEGIN PROJECT BY THIS DATE: Begun	COMPLETE PROJECT BY THIS DATE: October 1, 1988	WATER PUT TO FULL USE BY THIS DATE: October 1, 1990
--------------------------------------	---	--

---

---

REPORT

---

Background

On January 30, 1987, the City of Okanogan filed an application to appropriate public ground waters. The application was accepted, assigned number G4-29193, and public notice was made. The 30 day protest period expired on March 21, 1987. During that time a letter of protest was received from Philip W. Gum. Mr. Gum's letter had attached to it a petition signed by 26 people expressing concern over the water use proposed by the city. Three additional letters were received from Lewis Jones, Mildred Goff, and Jack and Orvilla Graves objecting to the city's application. These three letters were received two to three weeks following the end of the protest period and could not be accepted as formal protests. Their concerns are much the same as those expressed by Philip Gum and his concerns will be addressed later in this report.

Investigation

The following information was obtained from a pump test of the proposed well, site inspection by Don Abbott a Department of Ecology Geologist, review of office records, conversations with Mrs. Philip Gum, and conversations with Ron Cook of Gray and Osborne, consultant for the City of Okanogan.

The instant application requests authorization to construct a new well (well No. 5) and withdraw up to 650 gallons per minute (gpm) from the well for continuous municipal supply.

The city currently receives its municipal supply from four wells and Watercress Springs. The existing distribution system includes five reservoirs, one near the springs, two west of the central business district, one in the Elmway area and one east of the Okanogan River. The total storage capacity is 1,831,000 gallons. The system has two inline booster stations, each having two booster pumps (two 15 horsepower boosters are at the Highland Drive station and two 5 horsepower boosters are at the Murray Street station). The city is experiencing problems with delivering water to the southwest part of the city since none of the water sources or reservoirs are located in this area and the mainlines are undersized. In order to deal with this problem it was recommended to the city by their consulting engineers that they construct a well in the southwest area of town.

The city holds the following water rights:

1. Ground Water Certificate No. 266-D: 100 gpm, 29 acre-feet per year for municipal supply at Alma Park. The authorized well is located within the SE1/4NE1/4 of Section 17, T. 33 N., R. 26 E.W.M., approximately 100 feet from the Okanogan River. This dug well has been abandoned and an application for change has been filed to change the point of withdrawal to the city's well No. 1.
2. Ground Water Certificate No. 369-A: 500 gpm, 200 acre-feet per year for municipal supply. The authorized well is located in the SE1/4NE1/4 of Section 17, T. 33 N., R. 26 E.W.M., approximately 50 feet from the well described in Certificate No. 266-D. This drilled well is referred to as Well No. 1. Currently a 25 horsepower pump is installed in the well and 250 gpm is being withdrawn. Reportedly 350 gpm may be the maximum that has been withdrawn from the well.

3. Ground Water Certificate No. 3410-A: 200 gpm, 320 acre-feet per year for municipal supply. The certificate issued supplemental to existing rights, meaning that the total annual water use would not exceed 320 acre-feet per year under all rights. The authorized well is within the SE1/4NW1/4 Section 16, T. 33 N., R. 26 E.W.M. This drilled well is referred to as Well No. 2. A 25 horsepower pump is installed in the well and 180 to 200 gpm is currently being withdrawn.
4. Ground Water Certificate No. 5327-A: 650 gpm, 700 acre-feet per year for municipal supply. The certificate issued supplemental to existing rights, meaning that the total annual water use would not exceed 700 acre-feet per year under all rights. The authorized well is located in Government Lot 2 in Section 9, T. 33 N., R. 26 E.W.M. This drilled well is referred to as Well No. 3. A 75 horsepower pump is installed in the well and the authorized 650 gpm is currently being withdrawn.
5. Ground Water Certificate No. G4-23854C: 550 gpm, 400 acre-feet per year for municipal supply. The authorized well is located in the SE1/4NE1/4 Section 17, T. 33 N., R. 26 E.W.M. This drilled well is referred to as Well No. 4. A 100 horsepower pump is installed in the well and approximately 500 gpm is currently being withdrawn.
6. Water Right Claim No. 000052: Claims a right to divert 300 gpm, 484 acre-feet per year from springs (now called Watercress Springs) for municipal supply. The date of first water use on the claim is 1908. The springs are located in the SW1/4 Section 5, T. 33 N., R. 26 E.W.M. The springs flow seasonally varies from 175 gpm to the claimed 300 gpm.

The water right claim was filed as a result of Chapter 90.14 of the Revised Code of Washington (RCW), which required filing a water right claim for any use that was initiated prior to adoption of the State Surface and Ground Water Codes. The Surface Water Code was adopted in June 1917 and the Ground Water Code was adopted in June 1945. The determination of the validity and extent of a water right claim can be made only through a Superior Court general adjudication.

The existing ground water certificates authorize the use of a total of 2,000 gpm, 1,100 acre-feet per year. An additional 484 acre-feet per year is claimed from the springs, for a total annual water quantity of 1,584 acre-feet per year. According to the city's Water System Comprehensive Plan and Engineering Report, prepared in August 1986 by Gray & Osborne, Inc., the city's current population is approximately 2,337 and has a per capita water demand of 240 gallons per day. The city projects their population to be between 2,554 and 3,283 by the year 2010, which would require between 687 and 883 acre-feet per year. The existing water rights clearly allocate a sufficient annual quantity of water to meet the population needs well into the future. However, the city is in need of an additional instantaneous source of water in the south end of their service area in order to compensate for system deficiencies and peak daily demands.

The well proposed in the instant application has been constructed and is the city's Well No. 5. It is 18 inches in diameter and 110 feet deep. The well penetrates sands and gravels with interbedded silts. The well is located approximately 1,250 feet north and 1,650 feet east of the southwest corner of Section 17, being within the SE1/4SW1/4 Section 17, T. 33 N., R. 26 E.W.M. A pump test was conducted by Gray & Osborne with department staff monitoring. Department analysis of the pump test revealed that the aquifer penetrated by this well has an extremely high transmissivity, which allows for withdrawal of large quantities of water with little effect on water levels in neighboring wells. The well penetrates a water table aquifer that is recharged from the Okanogan River. The well is approximately 750 feet from the river, but is near the edge of an old flood channel, which contains water year-round. Following analysis of the aquifer characteristics, it was determined that over 80 percent of the water withdrawn from the well would be Okanogan River water if the well was pumped only 30 days. If the well was pumped the entire year almost 95 percent of the water would be from the river.

Under authority of, and in response to, the Water Resources Act of 1971, Chapter 90.54 RCW, the Department of Ecology was required to formulate a management and use program for the waters of the State of Washington. With the help of the Okanogan River Basin Advisory Group, the program for the Okanogan Basin was drafted and in July of 1976 was adopted as Chapter 173-549 of the Washington Administrative Code (WAC). It was revised effective July 19, 1984.

WAC 173-549, the Okanogan River Basin Plan, established minimum instream flows in the Okanogan and Similkameen Rivers as well as seasonally closing all tributary perennial streams to further consumptive appropriation and establishing guidelines for further appropriation from lakes and ponds. The basin plan provides that if development of ground water affects surface waters subject to the provisions of WAC 173-549, then rights to said ground water shall be subject to the same conditions as the affected surface water.

The City of Okanogan has filed an application for change to change the point of withdrawal for Certificate No. 369-A from their Well No. 1 in Alma Park to the new well. If the department is able to approve that request, the request under the instant application would be reduced to the difference between 650 gpm (capacity of well) and the quantity we approve for transfer under Certificate No. 369.

#### Consideration of Objections

Mr. Gum owns property and has two wells to the north and west of the newly constructed city well. He indicates that last year one of his wells almost went dry and he and his neighbors do not think that the aquifer can stand the pressure of a withdrawal the size proposed by the city. A petition signed by 26 neighboring landowners was attached to his letter. The petition also expresses concern over the proposed withdrawal by the City of Okanogan.

Mr. Gum is the holder of three certificates. Ground Water Certificate No. 1075, with a priority date of 1922, and Certificate No. G4-26085C, with a priority date of January 10, 1979, are appurtenant to the Gum property. They issued on a dug well 48 inches in diameter and 20 feet deep. The well is located approximately 900 feet from city well No. 5. The well is located within the E1/2NW1/4SW1/4 of Section 17, T. 33 N., R. 26 E.W.M. It is used to irrigate 19 acres within that parcel. An additional five acres are irrigated in the W1/2NW1/4SW1/4 Section 17 from the same well. Under the two certificates, a maximum of 300 gpm, 120.5 acre-feet per year for the irrigation of 24 acres is authorized. This is the well that almost went dry last year and is Mr. Gum's primary concern. He has a second well, which is authorized for use by Certificate No. G4-27385C, with a priority date of March 19, 1981. It is located over 1,000 feet from the city well. Mr. Gum's second well is six inches in diameter and 135 feet deep.

Besides the Gum certificates, there are three other ground water certificates with wells within half a mile of the city's new well. The wells authorized by these three certificates are between 25 and 48 feet deep and are constructed in the alluvial materials of the Okanogan River valley floor. There are several homes constructed in this area, but outside the city limits, that presumably receive their domestic water from wells constructed at their homes. Water right claims have been filed for several domestic wells in this neighborhood, however, there are no water well reports for these domestic wells. The authors of two of the three letters received after the protest period state that their source of water is a shallow well (30 feet deep). Considering that the wells in the valley floor that we have construction information for are very shallow, it is reasonable to assume that many of the unrecorded domestic wells are also shallow.

Well reports for deeper wells constructed along the Okanogan River indicate that the alluvial material in the valley floor is rather extensive, extending several hundred feet below land surface. Infiltration from the river into this material provides the water table aquifer that is utilized by both the shallow domestic and irrigation wells and the new well constructed by the city. The sands and gravels into which the wells are constructed are permeable, allowing for migration of water through the materials. Given the aquifer characteristics determined through the pump test, we can determine that the water level in a well 150 feet from the city well would drop only three feet if the city well were pumped at 650 gpm for an entire year.

As previously stated, the aquifer which the existing shallow wells utilize is considerably more extensive than the 20 to 48 feet they currently penetrate. Deepening of the wells would more fully penetrate the aquifer and eliminate the effect of minor fluctuations of water level. During the past three years, the annual precipitation has been well below normal, causing low flows in many of the rivers and streams in Okanogan County, including the Okanogan River. It is very likely that the fluctuations in the water table observed by Mr. Gum and his neighbors is the result of the lower flow in the Okanogan River, and not the result of an over allocated aquifer. Data collected by the department for wells adjacent to the Okanogan River indicates that they demonstrate regular cycles in water levels and that they are recharged annually by the spring freshet.

The Ground Water Code, Chapter 90.44 RCW, does provide that the prior appropriator shall as against subsequent appropriators from the same ground water body be entitled to the preferred use of such ground water to the extent of his appropriation and beneficial use, and shall enjoy the right to have any withdrawals by a subsequent appropriator of ground water limited to an amount that will maintain and provide a safe sustaining yield in the amount of prior appropriation. This does not mean that the prior appropriator is guaranteed his right to continue using a shallow well that has barely penetrated the aquifer. If he can obtain a safe sustaining yield in the amount of his prior appropriation by deepening the well, but still being within the same aquifer, subsequent appropriators would not be limited.

#### Conclusions

Based on the foregoing information, the following conclusions are made:

Subject to the provisions of WAC 173-549, water is available for the proposed beneficial use. Due to the extremely high transmissivity of the aquifer, the proposed water use should not be detrimental to existing rights. Granting a permit is not contrary to the public interest.

#### Recommendations

It is recommended that a permit issue for 650 gpm, 400 acre-feet per year for continuous municipal supply.

All water wells constructed within the state shall meet the minimum standards for construction and maintenance as provided under RCW 18.104 (Washington Water Well Construction Act of 1971) and Chapter 173-160 WAC (Minimum Standards for Construction and Maintenance of Water Wells).

Installation and maintenance of an access port as described in Ground Water Bulletin No. 1 is required. An air line and gage may be installed in addition to the access port.

A totalizing flow meter shall be installed on the well distribution system.

If the application for change which has been filed to change the point of withdrawal under Certificate No. 369-A is approved, the instantaneous quantity herein authorized shall be reduced by whatever quantity is approved.

During periods when the minimum flows for the lower reach of the Okanogan River are being violated, the city shall cease their pumping from well No. 5, under this authorization.

The annual quantity herein authorized is not in addition to the annual quantities authorized by Ground Water Certificates No. 266-D, No. 369-D, No. 3410-A, No. 5327-A and No. G4-23854C and claimed by Water Right Claim No. 000052, should a right be confirmed following an adjudication.

This authorization is subject to the provisions of Chapter 173-549 WAC as adopted in Olympia, Washington, August 14, 1976, and revised effective July 19, 1984, and the general rules of the Department of Ecology as specified under Chapter 173-500 WAC.

Instream flows as established at monitoring station 12.4472.00 at river mile 17, Section 9, T. 32 N., R. 25 E.W.M. and as presented in the table below shall be maintained by regulation of diversions as set forth in said WAC 173-549.

Instream flow hydrographs, as represented in WAC 173-549-900, shall be used for definition of instream flows on those days not specifically identified in WAC 173-549-020(2).  
Instream flows at Station 12.4472.00.

Month	Day	Instream Flow (cfs)	Month	Day	Instream Flow (cfs)
Jan.	1	860	Jul.	1	2100
	15	830		15	1200
Feb.	1	820	Aug.	1	800
	15	850		15	600
Mar.	1	880	Sep.	1	620
	15	900		15	700
Apr.	1	925	Oct.	1	750
	15	1100		15	960
May	1	1750	Nov.	1	950
	15	3800		15	950
Jun.	1	3800	Dec.	1	930
	15	3800		15	900

No diversion of water under this authorization shall take place when the flow of the river falls below the above flows.

REPORT BY: Becky Johnson  
Becky Johnson

DATE: 9/14/87

APPROVED BY: Doug Clausing  
Doug Clausing, Regional Supervisor

DATE: 9/14/1987

ska  
4x18



GWC – 3838

# Report of Examination on Ground Water

Received date 8-12-60 Date of exam. 9-21-60 No. 5702

Name Progressive Flat Water Assn. Address c/o Charles Rappo, Basy., Okanogan

Type of works well Dimensions 30" x 27"

Progress of works well dug to depth of 30 feet, may be deepened later.

Quantity claimed or applied for 150 g.p.m. \_\_\_\_\_ acre-feet per year

Legal sub. SW1/4 Sec. 6 Twp. 33 N. Rge. 26 E. County Okanogan

Use community domestic supply

Irrigation-acreage: Present \_\_\_\_\_ Planned \_\_\_\_\_ Feasible \_\_\_\_\_

Community of Progressive Flat as of the present

Municipal Population 87-100

Industrial \_\_\_\_\_

Time pump will be operated continuously

Other water rights appurtenant to this land none

Proximity to existing works, springs, wells, or streams Okanogan Valley Golf Club SNE 3/16 mi.

Area \_\_\_\_\_ Sub-area \_\_\_\_\_ Zone \_\_\_\_\_

## RECOMMENDATIONS

Approved for 150 g.p.m. 39 acre-feet per year, subject to existing

water rights. (1 acre-foot 325,850 gallons.) The installation of an access port to well as described in attached (Ground Water Bulletin No. 1 is recommended.

The water requirement for this application is calculated on a per capita use of 350 gallons per day or 39 acre-feet annually for a population of 100 persons.

Signed this 18th day of October, 1960.  
Division of Water Resources

*Ernest E. Levasseur*  
ERNEST E. LEVASSEUR, Engineer

GWC – 03410

# Report of Examination on Ground Water

Received date 2-21-48 Date of exam 5-21-59 Appl. No. 712  
Name City of Okanogan Address Okanogan, Wash.  
Type of works well Dimensions 12"x95"  
Progress of works well completed (march 1948)  
Quantity applied for 200 g.p.m. \_\_\_\_\_ acre-feet per year  
Legal sub. S2134 Sec 16 Twp. 13 N. Rge. 26 E. County Okanogan  
Use municipal supply

Irrigation-acreage: Present \_\_\_\_\_ Planned \_\_\_\_\_ Feasible \_\_\_\_\_  
Municipal: Population 2500 as of 1970  
Industrial \_\_\_\_\_  
Time pump will be operated continuously

Other water rights appurtenant to this land SW Cert 592, G.W. Certificates 265 & 266-D and 369-A.  
Proximity to existing works, springs, wells, or streams Okanogan River to the west

Area \_\_\_\_\_ Sub-area \_\_\_\_\_ Zone \_\_\_\_\_

## RECOMMENDATIONS

Approved for 200 g.p.m. 320 acre-feet per year, subject to existing water rights. (1 acre-foot 325,850 gallons.)

The City of Okanogan has the four certificates of water right listed above issued for a total withdrawal rate of 1675 gallons per minute and for an annual quantity of 1488 acre feet per year.  
Therefore, permit will issue for a continuous withdrawal rate of 200 g.p.m. or 320 acre-feet per year which will be supplemental to the above listed certificates.  
The applicant will furnish information to this office as to the size and type of equipment installed and the gallons per minute furnished. The size of hole openings and number of sprinklers operated, if such be the case, will give this information.

Signed this 19th day of May, 1959.

*Stuart E. Shumway*  
STUART E. SHUMWAY, Hydrogeologist  
Division of Water Resources

REPORT OF FINDINGS ON GROUND WATER Appl. 742

NAME City of Okanogan

TYPE OF WORKS: Well

Date of Examination March 9, 1948

Dimensions: 12" x 95'

Progress of Works well in - no pump

QUANTITY ~~Estimated~~

Applied for: 200

g.p.m.

acre feet per year

LOCATION NE $\frac{1}{2}$  of NW $\frac{1}{4}$  of 16-35-36 E.W.M.

USE: municipal

Irrigation- acreage: Present \_\_\_\_\_ Planned \_\_\_\_\_ Feasible \_\_\_\_\_

Municipal: Population 2150 as of \_\_\_\_\_

Industrial: \_\_\_\_\_

Time Pump Will be Operated: \_\_\_\_\_

Other Water Rights of Applicant: \_\_\_\_\_

Proximity to existing works, springs or streams: 500 feet West to

Okanogan River

Water Bearing Zone: \_\_\_\_\_

RECOMMENDATIONS

Approved for 200 g.p.m. 162 acre-feet  
per year, subject to existing water rights. (1 acre-foot = 325,950 gallons)

This well for the City of Okanogan is located across the bridge in the Eastern part of town which is part of the Colville Indian Reservation.

The present plan is to use it at 200 g.p.m. for 6 months in the summer so that 162 acre-feet a year will be produced.

Ground Water Application #321, Permit #341 will probably be cancelled as soon as this well is put into satisfactory operation.

Signed this 17th day of March, 1948

Fred E. Roberts  
FRED E. ROBERTS  
Ground Water Geologist

CG4 – GWC3838-A

GWC 3838-a

### Report of Examination on Ground Water

Received date 8-12-60 Date of exam. 9-21-60 No. 5702  
 Name Progressive Flat Water Assn. Address c/o Charles Rappo, Secy., Okanogan  
 Type of works well Dimensions 30"x27"  
 Progress of works well dug to depth of 30 feet, may be deepened later.  
 Quantity claimed or applied for 150 g.p.m. acre-feet per year  
 Legal sub. NW 1/4 Sec. 4 Twp. 33 N. Rge. 26 E. County Okanogan  
 Use community domestic supply  
 Irrigation-acreage: Present Community of Progressive Flat Planned \_\_\_\_\_ Feasible \_\_\_\_\_  
 Municipal: Population 87-100 as of the present  
 Industrial \_\_\_\_\_  
 Time pump will be operated continuously  
 Other water rights appurtenant to this land none  
 Proximity to existing works, springs, wells, or streams Okanogan Valley Golf Club ENE 3/16 mi.  
 Area \_\_\_\_\_ Sub-area \_\_\_\_\_ Zone \_\_\_\_\_

#### RECOMMENDATIONS

Approved for 150 g.p.m. 39 acre-feet per year, subject to existing

water rights. (1 acre-foot 325,850 gallons.) The installation of an access port to well as described in attached Ground Water Bulletin No. 1 is recommended.

The water requirement for this application is calculated on a per capita use of 350 gallons per day or 39 acre-feet annually for a population of 100 persons.

Signed this 18th day of October, 1960.  
 Division of Water Resources

*Ernest E. Levasseur*  
 ERNEST E. LEVASSEUR, Engineer



CG4 – GWC3838-A@2



STATE OF WASHINGTON  
DEPARTMENT OF ECOLOGY

**REPORT OF EXAMINATION FOR CHANGE**  
TO APPROPRIATE PUBLIC WATERS OF THE STATE OF WASHINGTON

- Surface Water (Issued in accordance with the provisions of Chapter 117, Laws of Washington for 1917, and amendments thereto, and the rules and regulations of the Department of Ecology.)
- Ground Water (Issued in accordance with the provisions of Chapter 263, Laws of Washington for 1945, and amendments thereto, and the rules and regulations of the Department of Ecology.)

PRIORITY DATE August 12, 1960	APPLICATION NUMBER CG4-GWC3838-A@2	PERMIT NUMBER	CERTIFICATE NUMBER
----------------------------------	---------------------------------------	---------------	--------------------

NAME Progressive Flat(s) Water Association (contact: Wayne Dezellem)			
ADDRESS (STREET) 7 Cherry Lane Road	(CITY) Okanogan	(STATE) WA	(ZIP CODE) 98840-8226

**PUBLIC WATERS TO BE APPROPRIATED**

SOURCE A well	TRIBUTARY OF (IF SURFACE WATERS)		
MAXIMUM CUBIC FEET PER SECOND	MAXIMUM GALLONS PER MINUTE 50	MAXIMUM ACRE- FEET PER YEAR 39	
QUANTITY, TYPE OF USE, PERIOD OF USE 50 gallons per minute and 39 acre-feet per year for municipal water supply and stockwatering.			

**LOCATION OF DIVERSION/WITHDRAWAL**

APPROXIMATE LOCATION OF DIVERSION-WITHDRAWAL Approximately 1350 feet south and 2080 feet west from the NE corner of Section 9, T. 33 N., R. 26 E.W.M.					
LOCATED WITHIN (SMALLEST LEGAL SUBDIVISION) SW¼NE¼	SECTION 9	TOWNSHIP N. 33	RANGE, (E OR W.) W.M. 26 E.	W.R.L.A. 49	COUNTY Okanogan

**RECORDED PLATTED PROPERTY**

LOT	BLOCK	OF (GIVE NAME OF PLAT OR ADDITION)
-----	-------	------------------------------------

**LEGAL DESCRIPTION OF PROPERTY ON WHICH WATER IS TO BE USED**

The place of use of this water right is the more recently approved of the following: (1) the legal description below, OR (2) the service area described in the most recent Water System Plan approved by the Washington State Department of Health after September 9, 2003, so long as the water right holder is and remains in compliance with the criteria in RCW 90.03.386(2). RCW 90.03.386 may have the effect of revising the place of use of this water right.

Section 4, 5, and 9, T. 33 N., R. 26 E.W.M.

**FILE COPY**

**DESCRIPTION OF PROPOSED WORKS**

Change the point of withdrawal for Ground Water Certificate No. 3838-A because of high uranium content and a severe decline in water production.

**DEVELOPMENT SCHEDULE**

BEGIN PROJECT BY THIS DATE: June 30, 2006	COMPLETE PROJECT BY THIS DATE: December 31, 2006	WATER PUT TO FULL USE BY THIS DATE: In good standing
--	---	---

**REPORT**

On January 27, 2006, Progressive Flat(s) Water Association of Okanogan, Washington, applied to change the point of withdrawal under Ground Water Certificate No. 3838-A to be used for continuous domestic supply. The application was accepted and assigned identifier No. CG4-GWC3838-A@2. RCW 90.44.100 allows changing the point of withdrawal for ground water certificates. Public Notice of the application was given in the Okanogan County Chronicle on February 15 and 22, 2006. There were no letters of protest or concern received during the 30-day protest period. This water right change application is categorically exempt under SEPA WAC 197-11-305 and WAC 197-11-800(4).

WAC 173-152-050(1)(c) Criteria for Priority Processing of Competing Applications states, "an application may be processed prior to competing applications if the application resolves or alleviates a public health or safety emergency caused by a failing public water supply system currently providing potable water to existing users." And, "a change in source is required to meet drinking water quality standards and avoid unreasonable treatment costs, or the State Department of Health determines that the existing source of supply is unacceptable for human use." Department of Health sent a letter to expedite the processing of associated Emergency Drought Authorization No. CG4-GWC3838-A@1 on November 5, 2005, because of a severe decline in water production and high uranium content. The letter to expedite the Emergency Drought Authorization also applies to this permanent change.

**Attributes of Ground Water Certificate No. 3838-A**

<b>Name on Certificate:</b>	Progressive Flat Water Association
<b>Priority Date:</b>	August 12, 1960
<b>Instantaneous Quantity:</b>	50 gallons per minute (gpm)
<b>Source:</b>	A well
<b>Annual Quantity:</b>	39 acre-feet per year (acre-ft/yr)
<b>Point of Withdrawal:</b>	NW $\frac{1}{4}$ NW $\frac{1}{4}$ Section 4, T. 33 N., R. 26 E.W.M.
<b>Period and Purpose of Use:</b>	Continuous community domestic supply and stockwatering
<b>Place of Use:</b>	Area served by Progressive Flat Water Association

**Proposed Change for Ground Water Certificate No. 3838A**

<b>Name of Applicant:</b>	Progressive Flat(s) Water Association
<b>Date of Application for Change:</b>	January 27, 2006
<b>Instantaneous Quantity:</b>	50 gpm
<b>Annual Quantity:</b>	39 acre-ft/yr
<b>Source:</b>	A well
<b>Point of Withdrawal:</b>	SW $\frac{1}{4}$ NE $\frac{1}{4}$ Section 9, T. 33 N., R. 26 E.W.M.
<b>Period and Purpose of Use:</b>	Continuous municipal supply and stockwatering
<b>Place of Use:</b>	Section 4, 5, and 9, T. 33 N., R. 26 E.W.M.

**INVESTIGATION**

To evaluate the change application for Water Ground Water Certificate No. G4-3838-A, the author conducted research of office records, maps and documents including, but not limited to the following: letter from the Department of Health (DOH), drought files, and the City of Okanogan Water System Plan. A summary of pertinent facts resulting from the research, investigations, and consultations follows.

**History of Water Use**

Ground Water Certificate No. 3838-A was issued to Progressive Flat Water Association (PFWA) with an August 12, 1960 priority date for community domestic supply and livestock. The original permit included 32 residences. Wayne Dezellum mentioned that water from this system is used for stockwatering during the winter. Irrigation water provides stockwater during the irrigation season.

Ground Water Change Authorization No. CG4-GWC3838-A was issued on April 10, 1994 to add a point of withdrawal (well) to an existing Certificate, for a total of two points of withdrawal. The original point of withdrawal is a shallow well with perforated casing that has had problems with the perforations becoming obstructed. The approved change application increased the number of residences that PFWA serves to 48 residences and 25 seasonal cabins for agricultural workers, but did not enlarge the water right. The file for the 1994 change application did not contain data for water use. The applicant also submitted a new application for additional water which was assigned identifier No. G4-30573 (see table below for water right information). The Department of Ecology (Ecology) approved this new application and issued a permit for 20 gpm and 6.3 acre-ft/yr for livestock and domestic use on March 11, 1994. Both Reports of Examination signed in 1994 mentioned that the well was dependant on irrigation water seeping into the aquifer.

During the summer of 2004, PFWA had problems with leaks in their system, which decreased water availability. Although the leaks were worked on, water production still diminished. During the winter of 2004-2005, water levels of the second well declined because of a mild winter and low snow pack that did not meet PFWA needs. Well water levels from March to October 2005 were critical. PFWA submitted a drought application on November 1, 2005 that was assigned identifier No. CG4-GWC3838-A@1 to withdraw water from the City of Okanogan Well No. 3. Ecology issued an Emergency Drought Authorization on November 4, 2005, that expired on December 31, 2005.

PFWA submitted metering information from their wells. The data is incomplete because of metering problems. From April through October 2004, water use varied from 14,000 to 28,434 gallons per day. PFWA water use has been less than what their authorized water rights because of low well yields. PFWA has not completed a water system plan. With the combination of incomplete metering information and no water system plan, the precise water use is uncertain. The City of Okanogan Water System Plan (issued in October 2000) estimates the daily per capita metered consumption at 222 gallons per day. Assuming an average occupancy of 2.5 people in each of the 73 residences, PFWA requires 45.38 acre-ft/yr. PFWA has two water rights (Ground Water Certificate No. 3838 and Permit No. G4-30573) that add up to 45.3 acre-ft/yr.

In Ground Water Application No. CG4-GWC3838-A@2, the applicant requests to transfer their points of withdrawal to existing City of Okanogan Well No. 3. In the application, the proposed gpm was included for City of Okanogan Well No. 3 instead of the amount of water to be transferred from the existing Progressive Flats Ground Water Certificate No. 3838-A. A phone conversation with Joe Mitschelen from the Rural Community Assistance Corporation clarified the transfer was for same quantity as Ground Water Certificate No. 3838-A.

#### Associated Water Rights

The City of Okanogan Well No. 3 is being proposed to serve the following Water Right Certificates and Permit (see table below). PFWA also applied to change the point of withdrawal for Ground Water Permit No. G4-30573P. The change application has a priority date of April 20, 2006 and was assigned identifier No. CG4-30573P. Ecology will process this application after receiving the affidavit of publication. The hydrogeology analysis for this report includes the change for Ground Water Permit No. G4-30573P, because it is part of the same overall project.

Water Right No.	Name on Water Right	Priority Date	Qi (gpm)	Qa (acre-ft/yr)	Point of Withdrawal
GWC-3838A	Progressive Flat Water Association	08/12/1960	50	39	NW¼NW¼ Section 4, T. 33 N., R. 26 E.W.M.
G4-30573P	Progressive Flat Water Association	01/22/1991	20	6.3	NW¼NW¼ Section 4, T. 33 N., R. 26 E.W.M.
GWC-5327A	City of Okanogan	09/13/1963	650	700	SW¼ NE¼ Section 9, T. 33 N., R. 26 E.W.M.

#### Other Ground Water Rights in the Vicinity

Ground Water Certificate No. 4738A issued to Columbia Concrete Pipe Company on August 14, 1963 for 200 gpm and 320 acre-ft/yr. Ray Clements, a public works employee for the City of Okanogan, said when the Concrete Pipe Company pumps its well at 200 gpm, it does not lower the water level at City Well No. 3. There are approximately 17 ground water exempt wells with ½ mile radius of City of Okanogan Well No. 3.

Water Right No.	Name on Water Right	Priority Date	Qi (gpm)	Qa (acre-ft/yr)	Point of Withdrawal
GWC-4738	Columbia Concrete Pipe Co.	08/14/1963	200	320	NW¼SW¼ Section 04, T. 33 N., R. 26 E.W.M.

#### HYDROGEOLOGIC SETTING

A licensed Ecology staff hydrogeologist reviewed and stamped a separate technical memorandum which discusses the hydrogeologic analysis of this application. The hydrogeologic interpretations provided below are extracted from this memorandum.

This section describes the general geology and hydrogeology in the vicinity of the PFWA wells located within the NW¼NW¼, Section 4, T. 33 N., R. 26 E.W.M. and the City of Okanogan's Well No. 3, located within the NW¼SW¼NE¼, Section 9, T. 33 N., R. 26 E.W.M. In the subject area, the Okanogan River flows in an overall southwesterly direction past the towns of Omak and Okanogan, and bedrock hills rising to the west. To the south-southwest, Salmon Creek, and the Salmon Creek Fault border the area of interest along the creek's lower reach near its confluence with the mainstem Okanogan. To the north-northeast, an unnamed intermittent creek drains the terraced highland in the direction of the Okanogan River Valley that lies below (details in hydrogeology report in file).

Here, as it also does to the north, the Okanogan River Valley runs generally coincident with the fault trace that defines the western edge of the Okanogan Metamorphic Core Complex. To the east of the Okanogan River Valley and the fault trace, mixed metamorphic rocks of the core complex form the eastern bedrock basement and walls of the main valley. To the west, igneous Pouge Mountain quartz monzonite and granite forms the western main valley walls and valley basement. The Pouge Mountain unit underlies the majority of the subject area, while minor occurrences of dacitic volcanic flows outcrop immediately to the north near the un-named creek drainage. Together, the metamorphic, igneous and volcanic units can be regarded as the bedrock floor or the lower boundary of the overlying unconsolidated sedimentary aquifer.

The overlying unconsolidated sediments were, for the most part, deposited during the most recent continental glaciation when the entire Okanogan drainage was overridden by the Okanogan Lobe of the Cordilleran ice sheet. As the ice melted and receded, deposits of cobbles, gravel, sand, till, silt and clay were left behind thinly lapping up onto and over bedrock surfaces, in terraces along the valley walls and as valley fill. More recently, the modern Okanogan River and its tributaries have re-worked much of the glacial materials and re-deposited them along with sands and gravels scoured from bedrock in the form of thin mantling, additional terraces and flood plains. Consequently, sediment thickness varies greatly with location from zero to more than 400 feet. Thickness variation is particularly apparent along the valley edges where ice marginal glacial sediments were deposited over valley fill sediments and onto an extremely irregular bedrock surface. Sediments within the mainstem valley more generally follow a pattern of greatest thickness in the vicinity of the valley axis.

Distribution of sediment packages transitions west to east from unsorted glacial drift to stratified ice marginal sediments to reworked glacial and alluvial sediments. The drift may contain till, outwash and glaciolacustrine silt and clay. Ice marginal sediments, having been washed of fines by glacial meltwater streams tend to consist of sands and gravels with negligible silt or clay content. Discontinuous lenses of silt and clay interfingered with the more dominant sands and gravels are common in the reworked glacial and alluvial valley fill sediments. A few well logs from this area record penetration of silt/clay in thicknesses from a few feet to some tens of feet; however, they do not suggest any vertical and horizontal prevalence of fine sediments as is observed farther north in the Okanogan River Valley above Ellisford.

Saturated thickness likewise transitions from west to east with the least saturated thickness occurring along the western sediment-bedrock boundary. Some perched lenses may occur within the terrace sediments with the main water table occurring just above the sediment-bedrock interface. Within the valley fill sediments, ground water levels range from about 80 feet to near land surface depending on location. Sediments here are assumed to be saturated from the water table surface to the bedrock base. Altogether, the saturated portion of the unconsolidated glacial and alluvial sediments form the aquifer that modern wells in this area draw ground water from today.

Recharge to the western and middle region of the aquifer is from precipitation and from imported recharge from irrigation conveyance losses, reclamation pond leakage and irrigation return flow. Discharge from this region of the aquifer is to wells, springs and to the lower portion of the aquifer to the east. Recharge to the lower portion of the aquifer is from precipitation, surface water exchange and discharge from the upper region. Discharge from the lower region is to wells, springs and to surface water when head relationships facilitate.

#### **Impairment, Qualifying Ground Water Withdrawal Facilities, and Well Interference**

There are three concepts that are important when considering whether a withdrawal of water from a well would impair another existing water right. The concepts are defined as follows:

Impairment is an adverse impact on the physical availability of water for a beneficial use that is entitled to protection (i.e. a water right).

Qualifying ground water withdrawal facilities are defined as those wells, which in the opinion of Ecology, are adequately constructed. An adequately constructed well is one that: (a) is constructed in compliance with well construction requirements; (b) fully penetrates the saturated thickness of an aquifer or withdraws water from a reasonable and feasible pumping lift (WAC 173-150); (c) the withdrawal facilities must be able to accommodate a reasonable variation in seasonal pumping water levels; and (d) the withdrawal facilities including pumping facilities must be properly sized to the ability of the aquifer to produce water.

Well interference may occur when several wells penetrate and withdraw ground water from the same aquifer. Each pumping well creates a drawdown cone. When several wells pump from the same aquifer, well density, aquifer characteristics and pumping demand, may result in individual drawdown cones that intersect and form a composite drawdown cone. At any point in an aquifer, the composite drawdown caused by pumping wells will be greatly influenced by the transmissivity (T) of the aquifer. In aquifers with high Ts, composite drawdown will generally be much less than in aquifers with similar properties but with low Ts. Transmissivity is related to hydraulic conductivity (K) and the saturated thickness (b) of an aquifer by the relationship  $T=Kb$ .

An aquifer's hydraulic conductivity (K) is derived from the physical properties of both the fluid and geologic materials that form an aquifer. Once formed, an aquifer's saturated thickness (b) becomes important in evaluating its Transmissivity. For regions of similar K in an aquifer, a large saturated thickness will result in a much higher T than a small saturated thickness. As a result, regions of similar K in an aquifer with a large saturated thickness will experience less composite drawdown or well interference than with a small saturated thickness.

Some conditions, however, will increase or steepen composite drawdown in an aquifer. For instance, where characteristics (such as very fine, clay rich, or poorly sorted sediments) of an unconfined aquifer cause significant drawdown relative to the saturated thickness, the composite drawdown will increase as the saturated thickness is reduced and the T becomes smaller. Additionally, in regions where negative or no-flow boundaries occur, such as near the edges of a valley fill aquifer where it is bounded by bedrock, composite drawdown will be steeper than in the central part (generally the greatest thickness region) of the aquifer. Consequently, it is commonly understood that the greatest composite drawdown or well interference is more likely to occur in regions of low transmissivities, thin saturated thicknesses and near negative or no-flow boundaries than in regions of high transmissivities, large saturated thicknesses, and away from negative or no-flow boundaries.

### **Aquifer Characteristics in the Vicinity of the PFWA Wells**

Ecology's well database contains three well logs for the PFWA. The original well, a 48-inch diameter dug well was constructed in 1960 and is located approximately 550 feet SE of the NW corner of Section 4, T. 33 N., R. 26 E.W.M. Two steel casings were later installed inside the original concrete casing and were noted by Ecology field staff during a site visit in 1994. A second well, drilled in 1987, was constructed approximately 45 feet NW of the original well and to a depth of 60 feet although it encounters bedrock at a depth of only 34 feet. The second well is screened into the sediments from 25 to 35 feet and was reportedly constructed to remedy chronic fouling of the original well's perforations. A third well was constructed in 2003, Well ID Tag No. AGM-015. Wayne Dezelle, contact for the water system, indicates this well is not approved by DOH and is not used by the system.

The PFWA wells are located in an outlying boundary region of the subject unconsolidated sediment aquifer. Bedrock outcrops suggest this area of the aquifer is limited by no-flow boundaries on two and possibly three sides. In addition, the aquifer here is limited by thickness and sediment characteristics. Locally, sediment thickness ranges from zero to perhaps 60 feet at the most and consists of poorly sorted gravel, sand, silt, hardpan, sandy clay, clay and broken rock. The broken rock tends to be present only at the sediment-bedrock interface.

Natural recharge to the aquifer in this area is limited to precipitation. Data collected at the Omak 2 NW Climate Station indicates precipitation here averages approximately 12 inches annually, only part of which is available as recharge to the aquifer. Imported recharge from irrigation conveyance losses, reclamation pond leakage and irrigation return flow appears to supplement aquifer recharge in this area and has been cited as a recharge source for this and other area systems in Ecology site investigations.

Construction of the PFWA wells demonstrated that the aquifer's saturated thickness measured only 16 to 24 feet locally. A pump test on the PFWA's well drilled in 1987 by CCT Well Drilling illustrates the aquifer's limitations in this specific area: Pumping at a rate of 45 to 120 gpm, it took only 12 minutes to draw ground water levels from 18 feet down to the top of the well screens at 25 feet. At 70 minutes, the driller began incremental reductions in the pumping rate to prevent water levels from dropping below the pump intake set at 32 feet. At 140 minutes, the pump rate had been dropped to 70 gpm when water levels had dropped to within 7 inches of the pump intake. Reduction of the pump rate to 52 gpm appeared to stabilize water levels briefly between 183 minutes to 240 minutes when the test was stopped. Recovery data indicates that at 25 minutes water levels had recovered to only 65% of the pre-test level.

The sediment type, thin saturated thickness, aquifer boundary conditions and the test performance all suggest this area of the aquifer may be characterized with a relatively low transmissivity. Further, as the aquifer is locally dewatered by either pumping or below average precipitation or both, transmissivity will decrease and well performance will deteriorate. This characterization appears to be consistent with declining water level data and system response reported by Gray & Osborne in a November 7, 2005, letter to Ecology requesting relief assistance.

Additionally, samples analyzed for RAD-RADIONUCLIDES from individual PFWA wells and collectively from the system indicate the presence of uranium and exceedances of Maximum Contaminant Levels (mcls) for gross alpha (minus uranium) in the ground water here. Samples taken over the period 1982 to the present confirm the condition is persistent and chronic. Although such conditions can vary widely from season to season, in this area they are directly related to the underlying rock type and possibly to the proximity of bedrock faults. While the condition can be successfully treated by coagulation/filtration, lime softening, reverse osmosis and ion exchange, the contaminants are naturally occurring and will continue to persist.

The PFWA wells are located at an elevation of approximately 1250 feet mean sea level (msl) and about 1800 feet horizontally from the un-named creek which discharges to the Okanogan River Valley below. From the well locations, bedrock boundaries are visible to the northwest and southeast. A bedrock boundary is also suspected to occur to the southwest below glacial drift materials, connecting the exposed NW and SE bedrock bodies. As a result, the ground water pathway to the lower portion of the aquifer likely reflects the influence of sub-surface bedrock boundaries. Ground water flow likely discharges from this area to the NE around the bedrock obstructions, toward the unnamed drainage, where it ultimately discharges to creek flow, the lower portion of the terrace sediments and to the river valley sediments.

### **Aquifer Characteristics in the Vicinity of Okanogan City Well No. 3**

City of Okanogan Well No. 3 is located approximately 1350 feet south and 2080 feet west of the NE corner of Section 9, T. 33 N., R. 26 E.W.M., at an elevation of approximately 900 feet msl. At this location, City Well No. 3 is approximately 6950 feet southeast horizontally of the PFWA wells. The 12-inch well was drilled in September of 1963 to a depth of 117 feet and exhibited a static water level of 75 feet on September 4, 1963. The well penetrates predominately coarse sands and gravels with only negligible occurrences of clay. The well's casing was perforated between 80 and 117 feet. A four hour pump test was performed, resulting in an estimated yield of approximately 1150 gpm with only 20 feet of drawdown.

A later test was conducted by the City in 1965 in response to reports of well interference at nearby shallow (16 to 30 feet) wells due to pumping at Well No. 3. The test monitored several neighboring wells while pumping Well No. 3 at a rate of 610 gpm for a period of four to five days. Results indicated that shallow wells at distances of up to 875 feet were affected with at least three wells reported to have gone dry. While the shallow wells clearly did not meet qualifying ground water withdrawal facilities requirements, lack of complaints in the file after July 2, 1965 suggest a satisfactory settlement was likely negotiated between the City and the affected parties.

Well No. 3 is positioned at the base of an ice marginal glacial terrace on the western edge of the mainstem valley floor. Between the PFWA wells and City Well No. 3, sediment thickness increases rapidly west to east reflecting both ice marginal and valley fill processes that deposited the sediment framework of the subject aquifer. For instance, while sediment thickness

at the PFWA wells is less than 60 feet, a well near the same elevation (~1250 feet msl), identified by Well ID Tag No. ALC512 and located approximately halfway between the PFWUA wells and City Well No. 3, encountered approximately 425 feet of sediments overlaying the apparent steeply sloping bedrock basement. By contrast, wells drilled into lower elevation (~900 to 810 feet msl) valley fill sediments generally do not penetrate the full saturated thickness of the aquifer since they tend to encounter sufficient water for their needs at relatively shallow depths. As a result, while well logs demonstrate valley floor sediment thicknesses of at least 138 feet, the total thickness in the valley area of the aquifer has not been established.

In contrast to the PFWA wells, sample history for City Well No. 3 suggests that only secondary (esthetic) contaminant exceedances, such as manganese, are related to the local geology. Sustainable capacity at City Well No. 3, in the range of 1000 gpm likewise contrasts with the comparatively poor yield of the PFWA wells (although well interference may be an issue). City Well No. 3 also has additional aquifer thickness that could be explored if necessary while the PFWUA wells have no additional aquifer thickness to exploit.

**Hydrogeologic Analysis**

Currently, City of Okanogan Well No. 3 is authorized to pump a maximum of 650 gpm and 700 acre-ft/yr under authorization No. G4-\*06878C (Ground Water Certificate No. 5327A). If approved for transfer, the authorization from Change Application No. CG4-GWC3838-A@2 will add a maximum of 50 gpm and 39 acre-ft/yr to the pumping rate at City Well No. 3 for a total of 700 gpm and 739 acre-ft/yr. If Permit No. G4-30573P is likewise transferred to City Well No. 3, another 20 gpm and 6.3 acre-ft/yr will also be added and result in a total maximum pumping rate of 720 gpm and 745.3 acre-ft/yr.

The pump tests discussed earlier and ground water literature suggest that aquifer transmissivity (T) is likely in the range of 65,000 to 100,000 gallons per day per foot (gpd/ft) in the vicinity of Well No. 3. Using T values within this range, evaluation by the Theis non-equilibrium equation for the additional 50 to 70 gpm suggests that additional drawdown as a result of the change approximately 50 feet from the well will be in the range of a foot or less. Consequently, effects due to the proposed change are expected to be largely unnoticed at nearby wells, which are also qualifying ground water withdrawal facilities. With the closest known well associated with a water right claim or certificate located approximately 300 feet from the subject well, composite drawdown/well interference which may be observed is not expected to be significant.

**Relationship Between the Original Source and Proposed Source**

In order to transfer or add a well to a water right, "the additional or replacement well or wells shall tap the same body of public ground water as the original well or wells," as stated in chapter 90.44.100(2a) RWC. The subject PFWA wells tap the same unconsolidated glacial/alluvial sediment aquifer as City of Okanogan Well No. 3 and do not appear to be separated by any continuous hydraulic barrier. Therefore, City of Okanogan Well No. 3 is considered to utilize the same body of ground water as the original PFWA wells.

**FINDINGS AND RECOMMENDATION**

The Legislature recently clarified the definition of municipal water supply (RCW 90.03.015). Under the authority of RCW 90.03.560, the purpose of use under this permit is now municipal supply since over 15 residences are served. The unperfected portion of this water right is not relinquished because it is a municipal water right.

In accordance with chapters 90.03 and 90.44 RCW, the author makes a tentative determination that Ground Water Certificate No. 3838-A is a valid right and is eligible for change.

Approval of this change as provisioned below will not cause impairment of existing water rights nor enlarge the water right.

Exercising this beneficial use of water at the new source will not be contrary to the public interest.

The proposed well taps the same body of ground water as the original well.

Based on the above investigation and findings, I recommend that the request to change a point of withdrawal to Omak Well No. 3 be authorized, subject to the provisions listed below.

**Purpose of Use and Authorized Quantities**

50 gpm for a maximum of 39 acre-ft/yr for municipal water supply.

**Point of Withdrawal**

Approximately 1350 feet south and 2080 feet west from the NE corner of Section 9, T. 33 N., R. 26 E.W.M.

**Place of Use**

Section 4, 5, and 9, T. 33 N., R. 26 E.W.M.

**Construction Schedule**

Begin construction by:	June 30, 2006
Complete construction by:	December 31, 2006
Apply water to full beneficial use by:	In good standing



**Provisions**

If the criteria in RCW 90.03.386(2) are not met, the place of use of this water right reverts to the service area described in the Water System Plan/Small Water System Management Program most recently approved after September 9, 2003. If the criteria in RCW 90.03.386(2) are not met and no WSP/SWSMP has been approved after September 9, 2003, the place of use reverts to the last place of use described by Ecology in a water right authorization.

An approved measuring device shall be installed and maintained for each of the sources identified by this water right in accordance with the rule "Requirements for Measuring and Reporting Water Use", Chapter 173-173 WAC.

Water use data shall be recorded weekly. The maximum rate of withdrawal and the annual total volume shall be submitted to Ecology by January 31<sup>st</sup> of each calendar year.

Chapter 173-173 WAC describes the requirements for data accuracy, device installation and operation, and information reporting. It also allows a water user to petition Ecology for modifications to some of the requirements. Installation, operation and maintenance requirements are enclosed as a document entitled "Water Measurement Device Installation and Operation Requirements".

The following information, including appropriate units of measure, shall be included with each submittal of water use data: owner, contact name if different, mailing address, daytime phone number, WRIA No., Permit No., source name, annual quantity used, maximum rate of withdrawal, Department of Health WFI water system number and source number(s), purpose of use, well tag number, and period of use. In the future, Ecology may require additional parameters to be reported or more frequent reporting. Ecology prefers web based data entry, but does accept hard copies. Ecology will provide forms and electronic data entry information.

Department of Ecology personnel, upon presentation of proper credentials, shall have access at reasonable times, to the records of water use that are kept to meet the above conditions, and to inspect at reasonable times any measuring device used to meet the above conditions.

All water wells constructed within the state shall meet the minimum standards for construction and maintenance as provided under RCW 18.104 (Washington Water Well Construction Act of 1971) and Chapter 173-160 WAC (Minimum Standards for Construction and Maintenance of Water Wells).

Installation and maintenance of an access port as described in Ground Water Bulletin No. 1 is required. An air line and gage may be installed in addition to the access port.

Report by: Virginia Stone  
Virginia Stone, Water Resources Program

6/7/06  
Date

**FINDINGS OF FACT AND DECISION**

Upon reviewing the above report, I find all facts, relevant and material to the subject application, have been thoroughly investigated. Furthermore, I find water is available for appropriation and the appropriation as recommended is a beneficial use and will not be detrimental to existing rights or the public welfare.

Therefore, I ORDER the requested changes for point of withdrawal and purpose of use under Ground Water Application No. CG4-GWC3838-A@2, be approved subject to existing rights and provisions specified in the foregoing report.

Signed at Yakima, Washington, this 2<sup>th</sup> day of June 2006.

G. Thomas Tebb For  
G. Thomas Tebb, L.E.G.  
Section Manager  
Water Resources Program  
Central Region Office

CG4 – 30573P



STATE OF WASHINGTON  
DEPARTMENT OF ECOLOGY

**REPORT OF EXAMINATION FOR CHANGE**  
TO APPROPRIATE PUBLIC WATERS OF THE STATE OF WASHINGTON

- Surface Water (Issued in accordance with the provisions of Chapter 117, Laws of Washington for 1917, and amendments thereto, and the rules and regulations of the Department of Ecology.)
- Ground Water (Issued in accordance with the provisions of Chapter 263, Laws of Washington for 1945, and amendments thereto, and the rules and regulations of the Department of Ecology.)

PRIORITY DATE January 22, 1991	APPLICATION NUMBER CG4-30573	PERMIT NUMBER	CERTIFICATE NUMBER
-----------------------------------	---------------------------------	---------------	--------------------

NAME Progressive Flat(s) Water Association (contact: Wayne Dezellem)			
ADDRESS (STREET) 7 Cherry Lane Road	(CITY) Okanogan	(STATE) WA	(ZIP CODE) 98840-8226

**PUBLIC WATERS TO BE APPROPRIATED**

SOURCE A well		
TRIBUTARY OF (IF SURFACE WATERS)		
MAXIMUM CUBIC FEET PER SECOND	MAXIMUM GALLONS PER MINUTE 20	MAXIMUM ACRE- FEET PER YEAR 6.3
QUANTITY, TYPE OF USE, PERIOD OF USE 20 gallons per minute and 6.3 acre-feet per year for municipal water supply and stockwatering.		

**LOCATION OF DIVERSION/WITHDRAWAL**

APPROXIMATE LOCATION OF DIVERSION-WITHDRAWAL Approximately 1350 feet south and 2080 feet west from the NE corner of Section 9, T. 33 N., R. 26 E.W.M.					
LOCATED WITHIN (SMALLEST LEGAL SUBDIVISION) SW $\frac{1}{4}$ NE $\frac{1}{4}$	SECTION 9	TOWNSHIP N. 33 N.	RANGE, (E. OR W.) W.M. 26 E.	W.R.L.A. 49	COUNTY Okanogan

**RECORDED PLATTED PROPERTY**

LOT	BLOCK	OF (GIVE NAME OF PLAT OR ADDITION)
-----	-------	------------------------------------

**LEGAL DESCRIPTION OF PROPERTY ON WHICH WATER IS TO BE USED**

The place of use of this water right is the more recently approved of the following: (1) the legal description below; OR (2) the service area described in the most recent Water System Plan approved by the Washington State Department of Health after September 9, 2003, so long as the water right holder is and remains in compliance with the criteria in RCW 90.03.386(2). RCW 90.03.386 may have the effect of revising the place of use of this water right.

Sections 4, 5, and 9, T. 33 N., R. 26 E.W.M.

**FILE COPY**

**DESCRIPTION OF PROPOSED WORKS**

Change the point of withdrawal for Ground Water Permit No. G4-30573 because of high uranium content and a severe decline in water production.

**DEVELOPMENT SCHEDULE**

BEGIN PROJECT BY THIS DATE October 1, 2006	COMPLETE PROJECT BY THIS DATE December 31, 2006	WATER PUT TO FULL USE BY THIS DATE December 31, 2007
---	--	---

**REPORT**

On April 20, 2006, Progressive Flat(s) Water Association of Okanogan, Washington, applied to change the point of withdrawal under Ground Water Permit No. G4-30573P to be used for continuous community supply. The application was accepted and assigned identifier No. CG4-30573. RCW 90.44.100 allows changing the point of withdrawal for ground water permits. Public Notice of the application was given in the Omak-Okanogan County Chronicle on April 26 and May 3, 2006. There were no letters of protest or concern received during the 30-day protest period. This water right change application is categorically exempt under SEPA WAC 197-11-305 and WAC 197-11-800(4).

WAC 173-152-050(1)(c) Criteria for Priority Processing of Competing Applications states, "an application may be processed prior to competing applications if the application resolves or alleviates a public health or safety emergency caused by a failing public water supply system currently providing potable water to existing users." And, "a change in source is required to meet drinking water quality standards and avoid unreasonable treatment costs, or the State Department of Health determines that the existing source of supply is unacceptable for human use." Department of Health (DOH) sent a letter to expedite the processing of application No. CG4-30573 on April 12, 2006, because of a severe decline in water production and high uranium content.

**Attributes of Water Right**

<b>Name on Permit:</b>	Progressive Flat Water Association
<b>Priority Date:</b>	January 22, 1991
<b>Instantaneous Quantity:</b>	20 gallons per minute (gpm)
<b>Source:</b>	2 wells
<b>Annual Quantity:</b>	6.3 acre-feet per year (acre-ft/yr)
<b>Point of Withdrawal:</b>	NW¼NW¼ Section 4, T. 33 N., R. 26 E.W.M
<b>Period and Purpose of Use:</b>	Continuous community domestic supply and stockwater
<b>Place of Use:</b>	Sections 4, 5, and 9, T. 33 N., R. 26 E.W.M.

**Proposed Change for Change Application No. G4-30573**

<b>Name of Applicant:</b>	Progressive Flat(s) Water Association
<b>Date of Application for Change:</b>	January 27, 2006
<b>Instantaneous Quantity:</b>	20 gpm
<b>Annual Quantity:</b>	6.3 acre-ft/yr
<b>Source:</b>	A well
<b>Point of Withdrawal:</b>	SW¼NE¼ Section 9, T. 33 N., R. 26 E.W.M.
<b>Period and Purpose of Use:</b>	Continuous municipal supply and stockwater
<b>Place of Use:</b>	Area served by Progressive Flat Water Association

**INVESTIGATION**

To evaluate the change application for Ground Water Permit No. G4-30573P, the author conducted research of office records, maps and documents including, but not limited to the following: letter from the DOH, drought files, and the City of Okanogan Water System Plan. A summary of pertinent facts resulting from the research, investigations, and consultations follows.

**History of Water Use and Associated Water Rights**

Department of Ecology (Ecology) issued Ground Water Permit No. G4-30573 to Progressive Flat Water Association (PFWA) with a January 22, 1991 priority date for community domestic supply and stockwater. The permit included 18 full time residences and 25 seasonal cabins. Wayne Dezellum mentioned that water from this system is used for stockwatering during the winter. Irrigation water provides stockwater during the irrigation season.

PFWA also has Ground Water Certificate No. 3838 for 50 gpm and 39 acre-ft/yr. PFWA submitted a change application to add a point of withdrawal and Ecology issued it on April 10, 1994. The approved change application increased the number of residences that PFWA serves to 48 residences and 25 seasonal cabins for agricultural workers. The file for the 1994 change application did not contain data for water use. Both PFWA Reports of Examination signed in 1994, including the original approval for Ground Water Permit No. G4-30573P, mentioned that the well was dependant on irrigation water seeping into the aquifer.

During the summer of 2004, PFWA had problems with leaks in their system which decreased water availability. Although the leaks were worked on, water production still diminished. During the winter of 2004-2005, water levels of the second well declined because of a mild winter and low snow pack that did not meet PFWA needs. Well water levels from March to October 2005 were below low/critical. PFWA submitted a drought application on November 1, 2005 that was assigned identifier No. CG4-GWC3838-A@1 to withdraw water from the City of Okanogan well. Ecology issued an Emergency Drought Authorization on November 4, 2005, that expired on December 31, 2005.

PFWA submitted metering information from their wells. The data is incomplete because of metering problems. From April through October 2004, water use varied from 14,000 to 28,434 gallons per day. PFWA water use has been less than what their water rights because of low well yields. PFWA has not completed a water system plan. With the combination of incomplete metering information and no water system plan, the precise water use is uncertain. The City of Okanogan Water System Plan (issued in October 2000) estimates the daily per capita metered consumption at 222 gallons per day. Assuming an average occupancy of 2.5 people in each of the 73 residences, PFWA requires 45.38 acre-ft/yr. PFWA has two water rights (Ground Water Certificate No. 3838A and Permit No. G4-30573P) that add up to 45.3 acre-ft/yr.

In Ground Water Application No. CG4-30573, the applicant requests to transfer their points of withdrawal to existing City of Okanogan Well No. 3. The City of Okanogan Well No. 3 is being proposed to serve the following Water Right Certificates and Permit (see table below). PFWA also applied to change the point of withdrawal for Ground Water Certificate No. 3838. The change application was assigned identifier No. CG4-GWC3838-A@2 and Ecology issued the Report of Examination (ROE) in June 2006. The hydrogeology analysis for this report includes the change for Ground Water Certificate No. CG4-GWC3838-A@2, because it is part of the same overall project.

Water Right No.	Name on Water Right	Priority Date	Qi (gpm)	Qa (acre-ft/yr)	Point of Withdrawal
GWC-3838A	Progressive Flat Water Assn	08/12/1960	50	39	NW¼NW¼ Section 4, T. 33 N., R. 26 E.W.M.
G4-30573P	Progressive Flat Water Assn	01/22/1991	20	6.3	NW¼NW¼ Section 4, T. 33 N., R. 26 E.W.M.
GWC-5327	City of Okanogan	09/13/1963	650	700	SW¼ NE¼ Section 9, T. 33 N., R. 26 E.W.M

#### Other Ground Water Rights

Ground Water Certificate No. 4738A issued to Columbia Concrete Pipe Company on August 14, 1963 for 200 gpm and 320 acre-ft/yr. Ray Clements, a public works employee for the City of Okanogan, said when Concrete Pipe Company pumps its well at 200 gpm, that it does not lower the water level at City Well No. 3. There are approximately 17 ground water exempt wells with ½-mile radius of City of Okanogan Well No. 3.

Water Right No.	Name on Water Right	Priority Date	Qi (gpm)	Qa (acre-ft/yr)	Point of Withdrawal
GWC-4738A	Columbia Concrete Pipe Co	08/14/1963	200	320	NW¼SW¼ Section 4, T. 33 N., R. 26 E.W.M.

#### HYDROGEOLOGIC SETTING

A licensed Ecology staff hydrogeologist reviewed and stamped a separate technical memorandum which discusses the hydrogeologic analysis of this application. The hydrogeologic interpretations provided below are extracted from this memorandum.

This section describes the general geology and hydrogeology in the vicinity of the PFWA wells located within the NW¼NW¼, Section 4, T. 33 N., R. 26 E.W.M., and the City of Okanogan's Well No. 3, located within the NW¼SW¼NE¼, Section 9, T. 33 N., R. 26 E.W.M. In the subject area, the Okanogan River flows in an overall southwesterly direction past the towns of Omak, Okanogan, and bedrock hills rising to the west. To the south-southwest, Salmon Creek, and the Salmon Creek Fault border the area of interest along the creek's lower reach near its confluence with the mainstem Okanogan. To the north-northeast, an unnamed intermittent creek drains the terraced highland in the direction of the Okanogan River Valley that lies below (details in hydrogeology report in file).

Here, as it also does to the north, the Okanogan River Valley runs generally coincident with the fault trace that defines the western edge of the Okanogan Metamorphic Core Complex. To the east of the Okanogan River Valley and the fault trace, mixed metamorphic rocks of the core complex form the eastern bedrock basement and walls of the main valley. To the west, igneous Pouge Mountain quartz monzonite and granite forms the western main valley walls and valley basement. The Pouge Mountain unit underlies the majority of the subject area, while minor occurrences of dacitic volcanic flows outcrop immediately to the north near the un-named creek drainage. Together, the metamorphic, igneous and volcanic units can be regarded as the bedrock floor or the lower boundary of the overlying unconsolidated sedimentary aquifer.

The overlying unconsolidated sediments were, for the most part, deposited during the most recent continental glaciation when the entire Okanogan drainage was overridden by the Okanogan Lobe of the Cordilleran ice sheet. As the ice melted and receded, deposits of cobbles, gravel, sand, till, silt and clay were left behind thinly lapping up onto and over bedrock surfaces, in terraces along the valley walls and as valley fill. More recently, the modern Okanogan River and its tributaries have re-worked much of the glacial materials and re-deposited them along with sands and gravels scoured from bedrock in the form of thin mantling, additional terraces and flood plains. Consequently, sediment thickness varies greatly with location from zero to more than 400 feet. Thickness variation is particularly apparent along the valley edges where ice marginal glacial sediments were deposited over valley fill sediments and onto an extremely irregular bedrock surface. Sediments within the mainstem valley more generally follow a pattern of greatest thickness in the vicinity of the valley axis.

Distribution of sediment packages transitions west to east from unsorted glacial drift to stratified ice marginal sediments to reworked glacial and alluvial sediments. The drift may contain till, outwash and glaciolacustrine silt and clay. Ice marginal sediments, having been washed of fines by glacial meltwater streams tend to consist of sands and gravels with negligible silt or clay content. Discontinuous lenses of silt and clay interfingering with the more dominant sands and gravels are common in the reworked glacial and alluvial valley fill sediments. A few well logs from this area record penetration of silt/clay in thicknesses from a few feet to some tens of feet; however, they do not suggest any vertical and horizontal prevalence of fine sediments as is observed farther north in the Okanogan River Valley above Ellisford.

Saturated thickness likewise transitions from west to east with the least saturated thickness occurring along the western sediment-bedrock boundary. Some perched lenses may occur within the terrace sediments with the main water table occurring just above the sediment-bedrock interface. Within the valley fill sediments, ground water levels range from about 80 feet to near land surface depending on location. Sediments here are assumed to be saturated from the water table surface to the bedrock base. Altogether, the saturated portion of the unconsolidated glacial and alluvial sediments form the aquifer that modern wells in this area draw ground water from today.

Recharge to the western and middle region of the aquifer is from precipitation and from imported recharge from irrigation conveyance losses, reclamation pond leakage and irrigation return flow. Discharge from this region of the aquifer is to wells, springs and to the lower portion of the aquifer to the east. Recharge to the lower portion of the aquifer of the aquifer is from precipitation, surface water exchange and discharge from the upper region. Discharge from the lower region is to wells, springs and to surface water when head relationships facilitate.

#### **Impairment, Qualifying Ground Water Withdrawal Facilities, and Well Interference**

There are three concepts that are important when considering whether a withdrawal of water from a well would impair another existing water right. The concepts are defined as follows:

Impairment is an adverse impact on the physical availability of water for a beneficial use that is entitled to protection (i.e. a water right).

Qualifying ground water withdrawal facilities are defined as those wells which in the opinion of the Department are adequately constructed. An adequately constructed well is one that (a) is constructed in compliance with well construction requirements; (b) fully penetrates the saturated thickness of an aquifer or withdraws water from a reasonable and feasible pumping lift (WAC 173-150); (c) the withdrawal facilities must be able to accommodate a reasonable variation in seasonal pumping water levels; and (d) the withdrawal facilities including pumping facilities must be properly sized to the ability of the aquifer to produce water.

Well interference may occur when several wells penetrate and withdraw ground water from the same aquifer. Each pumping well creates a drawdown cone. When several wells pump from the same aquifer, well density, aquifer characteristics and pumping demand, may result in individual drawdown cones that intersect and form a composite drawdown cone. At any point in an aquifer, the composite drawdown caused by pumping wells will be greatly influenced by the transmissivity (T) of the aquifer. In aquifers with high Ts, composite drawdown will generally be much less than in aquifers with similar properties but with low Ts. Transmissivity is related to hydraulic conductivity (K) and the saturated thickness (b) of an aquifer by the relationship  $T=Kb$ .

An aquifer's hydraulic conductivity (K) is derived from the physical properties of both the fluid and geologic materials that form an aquifer. Once formed, an aquifer's saturated thickness (b) becomes important in evaluating its Transmissivity. For regions of similar K in an aquifer, a large saturated thickness will result in a much higher T than a small saturated thickness. As a result, regions of similar K in an aquifer with a large saturated thickness will experience less composite drawdown or well interference than with a small saturated thickness.

Some conditions, however, will increase or steepen composite drawdown in an aquifer. For instance, where characteristics (such as very fine, clay rich, or poorly sorted sediments) of an unconfined aquifer cause significant drawdown relative to the saturated thickness, the composite drawdown will increase as the saturated thickness is reduced and the T becomes smaller. Additionally, in regions where negative or no-flow boundaries occur, such as near the edges of a valley fill aquifer where it is bounded by bedrock, composite drawdown will be steeper than in the central part (generally the greatest thickness region) of the aquifer. Consequently, it is commonly understood that the greatest composite drawdown or well interference is more likely to occur in regions of low transmissivities, thin saturated thicknesses and near negative or no-flow boundaries than in regions of high transmissivities, large saturated thicknesses, and away from negative or no-flow boundaries.

### **Aquifer Characteristics in the Vicinity of the PFWA Wells**

Ecology's well database contains three well logs for the PFWA. The original well, a 48-inch diameter dug well was constructed in 1960 and is located approximately 550 feet SE of the NW corner of Section 4, T. 33 N., R. 26 E.W.M. Two steel casings were later installed inside the original concrete casing and were noted by Ecology field staff during a site visit in 1994. A second well, drilled in 1987, was constructed approximately 45 feet NW of the original well and to a depth of 60 feet although it encounters bedrock at a depth of only 34 feet. The second well is screened into the sediments from 25 to 35 feet and was reportedly constructed to remedy chronic fouling of the original well's perforations. A third well was constructed in 2003, Well ID Tag No. AGM-015. Wayne Dezelle, contact for the water system, indicates this well is not approved by DOH and is not used by the system.

The PFWA wells are located in an outlying boundary region of the subject unconsolidated sediment aquifer. Bedrock outcrops suggest this area of the aquifer is limited by no-flow boundaries on two and possibly three sides. In addition, the aquifer here is limited by thickness and sediment characteristics. Locally, sediment thickness ranges from zero to perhaps 60 feet at the most and consists of poorly sorted gravel, sand, silt, hardpan, sandy clay, clay and broken rock. The broken rock tends to be present only at the sediment-bedrock interface.

Natural recharge to the aquifer in this area is limited to precipitation. Data collected at the Omak 2 NW Climate Station indicates precipitation here averages approximately 12 inches annually, only part of which is available as recharge to the aquifer. Imported recharge from irrigation conveyance losses, reclamation pond leakage and irrigation return flow appears to supplement aquifer recharge in this area and has been cited as a recharge source for this and other area systems in Ecology site investigations.

Construction of the PFWA wells demonstrated that the aquifer's saturated thickness measured only 16 to 24 feet locally. A pump test on the PFWA's well drilled in 1987 by CCT Well Drilling illustrates the aquifer's limitations in this specific area: Pumping at a rate of 45 to 120 gpm, it took only 12 minutes to draw ground water levels from 18 feet down to the top of the well screens at 25 feet. At 70 minutes, the driller began incremental reductions in the pumping rate to prevent water levels from dropping below the pump intake set at 32 feet. At 140 minutes, the pump rate had been dropped to 70 gpm when water levels had dropped to within 7 inches of the pump intake. Reduction of the pump rate to 52 gpm appeared to stabilize water levels briefly between 183 minutes to 240 minutes when the test was stopped. Recovery data indicates that at 25 minutes water levels had recovered to only 65% of the pre-test level.

The sediment type, thin saturated thickness, aquifer boundary conditions and the test performance all suggest this area of the aquifer may be characterized with a relatively low transmissivity. Further, as the aquifer is locally dewatered by either pumping or below average precipitation or both, transmissivity will decrease and well performance will deteriorate. This characterization appears to be consistent with declining water level data and system response reported by Gray & Osborne in a November 7, 2005, letter to Ecology requesting relief assistance.

Additionally, samples analyzed for RAD-RADIONUCLIDES from individual PFWA wells and collectively from the system indicate the presence of uranium and exceedances of Maximum Contaminant Levels (mcls) for gross alpha (minus uranium) in the ground water here. Samples taken over the period 1982 to the present confirm that the condition is persistent and chronic. Although such conditions can vary widely from season to season, in this area they are directly related to the underlying rock type and possibly to the proximity of bedrock faults. While the condition can be successfully treated by coagulation/filtration, lime softening, reverse osmosis and ion exchange, the contaminants are naturally occurring and will continue to persist.

The PFWA wells are located at an elevation of approximately 1250 feet mean sea level (msl) and about 1800 feet horizontally from the un-named creek which discharges to the Okanogan River Valley below. From the well locations, bedrock boundaries are visible to the northwest and southeast. A bedrock boundary is also suspected to occur to the southwest below glacial drift materials, connecting the exposed NW and SE bedrock bodies. As a result, the ground water pathway to the lower portion of the aquifer likely reflects the influence of sub-surface bedrock boundaries. Ground water flow likely discharges from this area to the NE around the bedrock obstructions, toward the unnamed drainage, where it ultimately discharges to creek flow, the lower portion of the terrace sediments and to the river valley sediments.

### **Aquifer Characteristics in the Vicinity of Okanogan City Well No. 3**

City of Okanogan Well No. 3 is located approximately 1350 feet south and 2080 feet west of the NE corner of Section 9, T. 33 N., R. 26 E.W.M., at an elevation of approximately 900 feet msl. At this location, City Well No. 3 is approximately 6950 feet southeast horizontally of the PFWA wells. The 12-inch well was drilled in September of 1963 to a depth of 117 feet and exhibited a static water level of 75 feet on September 4, 1963. The well penetrates predominately coarse sands and gravels with only negligible occurrences of clay. The well's casing was perforated between 80 and 117 feet. A four hour pump test was performed, resulting in an estimated yield of approximately 1150 gpm with only 20 feet of drawdown.

A later test was conducted by the City in 1965 in response to reports of well interference at nearby shallow (16 to 30 feet) wells due to pumping at Well No. 3. The test monitored several neighboring wells while pumping Well No. 3 at a rate of 610 gpm for a period of four to five days. Results indicated that shallow wells at distances of up to 875 feet were affected with at least three wells reported to have gone dry. While the shallow wells clearly did not meet qualifying ground water withdrawal facilities requirements, lack of complaints in the file after July 2, 1965 suggest a satisfactory settlement was likely negotiated between the City and the affected parties.

Well No. 3 is positioned at the base of an ice marginal glacial terrace on the western edge of the mainstem valley floor. Between the PFWA wells and City Well No. 3, sediment thickness increases rapidly west to east reflecting both ice marginal and valley fill processes that deposited the sediment framework of the subject aquifer. For instance, while sediment thickness



at the PFWA wells is less than 60 feet, a well near the same elevation (~1250 feet msl), identified by Well ID Tag No. ALC512 and located approximately halfway between the PFWA wells and City Well No. 3, encountered approximately 425 feet of sediments overlying the apparent steeply sloping bedrock basement. By contrast, wells drilled into lower elevation (~900 to 810 feet msl) valley fill sediments generally do not penetrate the full saturated thickness of the aquifer since they tend to encounter sufficient water for their needs at relatively shallow depths. As a result, while well logs demonstrate valley floor sediment thicknesses of at least 138 feet, the total thickness in the valley area of the aquifer has not been established.

In contrast to the PFWA wells, sample history for City Well No. 3 suggests that only secondary (esthetic) contaminant exceedances, such as manganese, are related to the local geology. Sustainable capacity at City Well No. 3, in the range of 1000 gpm likewise contrasts with the comparatively poor yield of the PFWA wells (although well interference may be an issue). City Well No. 3 also has additional aquifer thickness that could be explored if necessary while the PFWUA wells have no additional aquifer thickness to exploit.

**Hydrogeologic Analysis**

Currently, City of Okanogan Well No. 3 is authorized to pump a maximum of 650 gpm and 700 acre-ft/yr under authorization No. G4-06878C (Ground Water Certificate No. 5327). The approval of Change Application No. CG4-GWC3838-A@2 added 50 gpm and 39 acre-ft/yr to the pumping rate at City Well No. 3. If Ground Water Permit No. G4-30573P is also transferred to City Well No. 3, an additional 20 gpm and 6.3 acre-ft/yr will be added and result in a total maximum pumping rate of 720 gpm and 745.3 acre-ft/yr.

The pump tests discussed earlier and ground water literature suggest that aquifer transmissivity (T) is likely in the range of 65,000 to 100,000 gallons per day per foot (gpd/ft) in the vicinity of Well No. 3. Using T values within this range, evaluation by the Theis non-equilibrium equation for the additional 50 to 70 gpm suggests that additional drawdown as a result of the change approximately 50 feet from the well will be in the range of a foot or less. Consequently, effects due to the proposed change are expected to be largely unnoticed at nearby wells which are also qualifying ground water withdrawal facilities. With the closest known well associated with a water right claim or certificate located approximately 300 feet from the subject well, composite drawdown/well interference which may be observed is not expected to be significant.

**Relationship Between the Original Source and Proposed Source**

In order to transfer or add a well to a water right, "the additional or replacement well or wells shall tap the same body of public ground water as the original well or wells," as stated in chapter 90.44.100(2a) RWC. The subject PFWA wells tap the same unconsolidated glacial/alluvial sediment aquifer as City of Okanogan Well No. 3 and do not appear to be separated by any continuous hydraulic barrier. Therefore, City of Okanogan Well No. 3 is considered to utilize the same body of ground water as the original PFWA wells.

**FINDINGS AND RECOMMENDATION**

The Legislature recently clarified the definition of municipal water supply (RCW 90.03.015). Under the authority of RCW 90.03.560, the purpose of use under this permit is now municipal supply since over 15 residences are served. The unperfected portion of this water right is not relinquished because it is a municipal water right.

In accordance with chapters 90.03 and 90.44 RCW, the author makes a tentative determination that Ground Water Permit No. G4-30573P is a valid right and is eligible for change.

Approval of this change as provisioned below will not cause impairment of existing water rights nor enlarge the water right.

Exercising this beneficial use of water at the new source will not be contrary to the public interest.

The proposed well taps the same body of ground water as the original well.

Water is available in the aquifer at the new source.

Based on the above investigation and findings, I recommend that the request to change a point of withdrawal to City of Okanogan Well No. 3 be authorized, subject to the provisions listed below.

**Purpose of Use and Authorized Quantities**

20 gpm for a maximum of 6.3 acre-ft/yr for municipal water supply.

**Point of Withdrawal**

Approximately 1350 feet south and 2080 feet west from the NE corner of Section 9, T. 33 N., R. 26 E.W.M.

**Place of Use**

Sections 4, 5, and 9, T. 33 N., R. 26 E.W.M.

**Construction Schedule**

<b>Begin construction by:</b>	October 1, 2006
<b>Complete construction by:</b>	December 31, 2006
<b>Apply water to full beneficial use by:</b>	December 31, 2007

Provisions

If the criteria in RCW 90.03.386(2) are not met, the place of use of this water right reverts to the service area described in the Water System Plan/Small Water System Management Program most recently approved after September 9, 2003. If the criteria in RCW 90.03.386(2) are not met and no WSP/SWSMP has been approved after September 9, 2003, the place of use reverts to the last place of use described by Ecology in a water right authorization.

An approved measuring device shall be installed and maintained for each of the sources identified by this water right in accordance with the rule "Requirements for Measuring and Reporting Water Use", Chapter 173-173 WAC.

Water use data shall be recorded weekly. The maximum rate of withdrawal and the annual total volume shall be submitted to Ecology by January 31<sup>st</sup> of each calendar year.

Chapter 173-173 WAC describes the requirements for data accuracy, device installation and operation, and information reporting. It also allows a water user to petition Ecology for modifications to some of the requirements. Installation, operation and maintenance requirements are enclosed as a document entitled "Water Measurement Device Installation and Operation Requirements".

The following information, including appropriate units of measure, shall be included with each submittal of water use data: owner, contact name if different, mailing address, daytime phone number, WRIA No., Permit No., source name, annual quantity used, maximum rate of withdrawal, Department of Health WFI water system number and source number(s), purpose of use, well tag number, and period of use. In the future, Ecology may require additional parameters to be reported or more frequent reporting. Ecology prefers web based data entry, but does accept hard copies. Ecology will provide forms and electronic data entry information.

Department of Ecology personnel, upon presentation of proper credentials, shall have access at reasonable times, to the records of water use that are kept to meet the above conditions, and to inspect at reasonable times any measuring device used to meet the above conditions.

All water wells constructed within the state shall meet the minimum standards for construction and maintenance as provided under RCW 18.104 (Washington Water Well Construction Act of 1971) and Chapter 173-160 WAC (Minimum Standards for Construction and Maintenance of Water Wells).

Installation and maintenance of an access port as described in Ground Water Bulletin No. 1 is required. An air line and gage may be installed in addition to the access port.

Report by: Virginia Stone  
Virginia Stone, Water Resources Program

7/15/06  
Date

**FINDINGS OF FACT AND DECISION**

Upon reviewing the above report, I find all facts, relevant and material to the subject change application, have been thoroughly investigated. Furthermore, I find water is available for appropriation and the appropriation as recommended is a beneficial use and will not be detrimental to existing rights or the public welfare.

Therefore, I ORDER the requested changes for point of withdrawal and purpose of use under Ground Water Application No. CG4-30273, be approved subject to existing rights and provisions specified in the foregoing report.

Signed at Yakima, Washington, this 10<sup>th</sup> day of July 2006.

  
G. Thomas Tebb, L.E.G.  
Section Manager  
Water Resources Program  
Central Region Office

G4 – 30573

STATE OF WASHINGTON  
DEPARTMENT OF ECOLOGY

*file*

**REPORT OF EXAMINATION**

TO APPROPRIATE PUBLIC WATERS OF THE STATE OF WASHINGTON

Surface Water (Issued in accordance with the provisions of Chapter 117, Laws of Washington for 1917, and amendments thereto, and the rules and regulations of the Department of Ecology.)

Ground Water (Issued in accordance with the provisions of Chapter 263, Laws of Washington for 1945, and amendments thereto, and the rules and regulations of the Department of Ecology.)

PRIORITY DATE January 22, 1991	APPLICATION NUMBER G4-30573	PERMIT NUMBER	CERTIFICATE NUMBER
-----------------------------------	--------------------------------	---------------	--------------------

NAME Progressive Flat Water Users Association			
ADDRESS (STREET) PO Box 581	(CITY) Okanogan	(STATE) Washington	(ZIP CODE) 98840-0581

**PUBLIC WATERS TO BE APPROPRIATED**

SOURCE two wells
TRIBUTARY OF (IF SURFACE WATERS)

MAXIMUM CUBIC FEET PER SECOND	MAXIMUM GALLONS PER MINUTE 20	MAXIMUM ACRE-FEET PER YEAR 6.3
-------------------------------	----------------------------------	-----------------------------------

QUANTITY, TYPE OF USE, PERIOD OF USE  
6.3 acre-feet per year for continuous community domestic supply to 18 full time residences, 25 seasonal cabins, and stockwater.

**LOCATION OF DIVERSION/WITHDRAWAL**

APPROXIMATE LOCATION OF DIVERSION-WITHDRAWAL  
502.55 feet southeast from the northwest corner of Section 4;  
550 feet southeast from the northwest corner of Section 4.

LOCATED WITHIN (SMALLEST LEGAL SUBDIVISION) NW $\frac{1}{4}$ NW $\frac{1}{4}$	SECTION 4	TOWNSHIP N. 33	RANGE, (E. OR W.) W.M. 26 E.	W.R.L.A. 49	COUNTY Okanogan
--	--------------	-------------------	---------------------------------	----------------	--------------------

**RECORDED PLATTED PROPERTY**

LOT	BLOCK	OF (GIVE NAME OF PLAT OR ADDITION)
-----	-------	------------------------------------

**LEGAL DESCRIPTION OF PROPERTY ON WHICH WATER IS TO BE USED**

Sections 4, 5, and 9 of T. 33 N., R. 26 E.W.M., Okanogan County, Washington.

---

---

**DESCRIPTION OF PROPOSED WORKS**

---

---

A well 8 inches in diameter and 60 feet deep and an older well 30 feet deep, both with 5 horsepower submersible pumps.

---

---

**DEVELOPMENT SCHEDULE**

---

---

BEGIN PROJECT BY THIS DATE:	COMPLETE PROJECT BY THIS DATE:	WATER PUT TO FULL USE BY THIS DATE:
Begun	July 1, 1995	July 1, 1996

---

---

---

---

**REPORT**

---

---

Background

On January 22, 1991, Progressive Flat Water Users Association of Okanogan, Washington filed an application to appropriate public waters from two wells in the amount of 20 gallons per minute (gpm) each year for continuous multiple domestic supply and stockwater. The application was accepted, assigned number G4-30573, and public notice was made. There was one protest received from the Okanogan Irrigation District during the 30 day protest period and later withdrawn.

The Progressive Flat Water Users Association (PFWUA) under Ground Water Certificate No. 3838-A is authorized the withdrawal of 50 gpm and 39 acre-feet per year to provide community domestic water for up to 32 rural residences. Even though the Certificate did not mention a specific number of residences, this number is derived from the underlying Report of Examination and Permit. The State Department of Health has approved the PFWUA for 41 hook ups. Applicant also submitted an application for change under Certificate No. 3838-A which has been recommended for approval to add a point of withdrawal.

Site Inspection

The following information was obtained from a site inspection conducted by Philip Kerr on January 10, 1994, research of department records, and conversations with the PFWUA president Ray Moon, other members of the association, and department staff.

The applicant requests authorization for 20 gpm to provide water to 18 additional full time residences, 25 seasonal temporary cabins and stockwater for approximately 10 animals. The requested 20 gpm was to be in addition to the 50 gpm already authorized under Certificate No. 3838-A for a total of 70 gpm.

The place of use is located approximately ½ mile northwest of Okanogan, Washington. The PFWUA has approximately 42 active hook ups with plans for expansion to 50 hook ups within Sections 4, 5, and 9, T. 33 N., R. 26 E.W.M. Some of these hook ups also serve cabins for farm workers which are only used a few months a year. There are a total of 25 cabins.

The points of withdrawal are located approximately 502.55 feet southeast of the northwest corner of Section 4 within the NW¼NW¼ of Section 4, T. 33 N., R. 26 E.W.M. The new well is reported to be 8 inches in diameter and 60 feet deep with a static water level of 18 feet below the top of the well in July 1987. The static water level on January 10, 1994 was 12 feet below the ground surface. The well report shows that the well penetrates top soil to 3 feet, sandy clay to 14 feet, brown clay to 21 feet; broken rock, silt and water to 34 feet and granite to 60 feet.

The new well was constructed because the old well located approximately 45 feet southeast from the new well was having problems with the well casing perforations sealing off. The old well located inside the pump house was reported to be a 30 foot deep dug well which now has two steel casings inside. Only one casing has a pump installed. The static water level during the inspection was 14 feet below the top of the well casing. Both wells appear to be getting water from the same aquifer and each well has a 5 horsepower submersible pump connected to a common pressure tank and distribution system.

### Water Quantities

Ground Water Certificate No. 3838-A authorized the withdrawal of 50 gpm and 39 acre-feet per year for continuous community domestic supply for 32 homes. With improved water conservation measures and the requirement for in-house use only of 800 gallons per day for each house, a total of 44.8 acre-feet of water would be needed for 50 full time residences. The 25 seasonal temporary cabins, each cabin using 50 gallons per day for 90 days, would only require .35 acre-feet of water per year. The stockwater requirement of 15 gallons per day for 10 animals would require .17 acre-feet of water per year. This would require a total of 45.3 acre-feet of water per year. This means only an additional 20 gpm and 6.9 acre-feet of water is required under instant application in addition to the 50 gpm and 39 acre-feet authorized under Certificate No. 3838-A.

### Water Availability

The aquifer penetrated by the subject wells appears to be a shallow aquifer lying over granite. There are numerous wells within 1 mile of the subject well with well logs showing penetration of soil, sand and gravel to about 20 feet, then clay and some sand and gravel to about 60 feet, then soft granite or bedrock. Most wells show a static water level of 11 to 36 feet. The aquifer is thought to be recharged from seepage out of an Okanogan Irrigation District reclamation pond, local precipitation, and irrigation water return flows.

There is an Okanogan Irrigation District (OID) irrigation ditch which is located approximately ¼ mile west and upslope from applicants property. The ditch is concrete lined and diverts water from Salmon Creek to Duck Lake. There is also a reclamation pond within ½ mile of subject well which the OID keeps full from the ditch. The author believes water is seeping from the reclamation pond and significantly contributing to the aquifer from which water is being withdrawn by the subject wells and other wells in the vicinity. The shallow depth to water in the wells suggests a water table aquifer which is directly continuous with the OID pond. Should the pond go dry or action be taken to reduce its leakage, many wells in the area may go dry or at least their yields significantly reduced.

### Impairment of Existing Rights

There are numerous Water Right Certificates and Claims within 1 mile of the subject well. These rights are primarily for single domestic and small irrigation projects. The additional withdrawal of 20 gpm and 6.3 acre-feet per year should not impair existing rights. The addition of 18 full time residences and the other uses to the Progressive Flat Water Users Association community domestic supply system would be more advantageous to the aquifer than additional exempt wells being drilled to meet the demand.

### Conclusions

Based on the foregoing information, the following conclusions are made:

Continuous community domestic supply and stockwater are beneficial uses. Water is physically available at the site for the proposed beneficial uses.

The water availability at this setting could change drastically should the OID reclamation pond use be discontinued or the pond sealed to prevent seepage. The department could not preclude OID improvements to cut water loss from the pond even if it is the primary reason this aquifer system exists.

Granting a permit for multiple domestic supply and stockwater is not contrary to the public interest.

### Recommendations

Based on the above facts and conclusions a continued instantaneous quantity of 20 gpm and 6.3 acre-feet per year are recommended for approval in addition to that authorized under Certificate No. 3838-A for continuous multiple domestic use to 18 full time residences, 25 seasonal temporary cabins, and stockwater. The following provisions apply:

Report Continued

Water pumped from the old well or the new well or both wells at the same time must not exceed 70 gpm and 45.3 acre-feet per year.

The water sources and/or water transmission facilities may not be located entirely upon the land owned by the applicant. Therefore, the applicant is advised that issuance of a permit by this department for appropriation of the waters in question does not convey a right of access to, or other right to use, land which the applicant does not legally possess.

This authorization shall in no way excuse the permittee from compliance with any applicable federal, state, or local statutes, ordinances, or regulations including those administered by other programs of the Department of Ecology and those administered by local and state health departments for public water supplies (2 or more service units). Increasing the number of hook ups may require additional storage capacity.

A suitable measuring device approved by the Department of Ecology shall be installed and maintained in accordance with WAC 508-64-020 through WAC 508-64-040. (Installation, operation and maintenance requirements attached hereto.)

Whenever water is being diverted, bi-weekly (every two weeks) readings of the measuring device shall be recorded and maintained by the permittee. These records shall be made available to the Department of Ecology upon request.

A proof inspection will be conducted prior to final certificate issuance. The certificate will reflect the extent of the project perfected within the limitations of the permit. Aspects will include as appropriate the source(s), system instantaneous capacity, beneficial use(s), annual quantity, home services designed, place of use, and satisfaction of provisions.

REPORT BY: Philip N. Kerr DATE: March 9, 1994  
Philip N. Kerr

APPROVED BY: Doug Clausing DATE: 3/11/1994  
Doug Clausing, Section Manager

6x114 ska



at the PFWA wells is less than 60 feet, a well near the same elevation (~1250 feet msl), identified by Well ID Tag No. ALC512 and located approximately halfway between the PFWA wells and City Well No. 3, encountered approximately 425 feet of sediments overlaying the apparent steeply sloping bedrock basement. By contrast, wells drilled into lower elevation (~900 to 810 feet msl) valley fill sediments generally do not penetrate the full saturated thickness of the aquifer since they tend to encounter sufficient water for their needs at relatively shallow depths. As a result, while well logs demonstrate valley floor sediment thicknesses of at least 138 feet, the total thickness in the valley area of the aquifer has not been established.

In contrast to the PFWA wells, sample history for City Well No. 3 suggests that only secondary (esthetic) contaminant exceedances, such as manganese, are related to the local geology. Sustainable capacity at City Well No. 3, in the range of 1000 gpm likewise contrasts with the comparatively poor yield of the PFWA wells (although well interference may be an issue). City Well No. 3 also has additional aquifer thickness that could be explored if necessary while the PFWUA wells have no additional aquifer thickness to exploit.

**Hydrogeologic Analysis**

Currently, City of Okanogan Well No. 3 is authorized to pump a maximum of 650 gpm and 700 acre-ft/yr under authorization No. G4-\*06878C (Ground Water Certificate No. 5327). The approval of Change Application No. CG4-GWC3838-A@2 added 50 gpm and 39 acre-ft/yr to the pumping rate at City Well No. 3. If Ground Water Permit No. G4-30573P is also transferred to City Well No. 3, an additional 20 gpm and 6.3 acre-ft/yr will be added and result in a total maximum pumping rate of 720 gpm and 745.3 acre-ft/yr.

The pump tests discussed earlier and ground water literature suggest that aquifer transmissivity (T) is likely in the range of 65,000 to 100,000 gallons per day per foot (gpd/ft) in the vicinity of Well No. 3. Using T values within this range, evaluation by the Theis non-equilibrium equation for the additional 50 to 70 gpm suggests that additional drawdown as a result of the change approximately 50 feet from the well will be in the range of a foot or less. Consequently, effects due to the proposed change are expected to be largely unnoticed at nearby wells which are also qualifying ground water withdrawal facilities. With the closest known well associated with a water right claim or certificate located approximately 300 feet from the subject well, composite drawdown/well interference which may be observed is not expected to be significant.

**Relationship Between the Original Source and Proposed Source**

In order to transfer or add a well to a water right, “the additional or replacement well or wells shall tap the same body of public ground water as the original well or wells,” as stated in chapter 90.44.100(2a) RWC. The subject PFWA wells tap the same unconsolidated glacial/alluvial sediment aquifer as City of Okanogan Well No. 3 and do not appear to be separated by any continuous hydraulic barrier. Therefore, City of Okanogan Well No. 3 is considered to utilize the same body of ground water as the original PFWA wells.

**FINDINGS AND RECOMMENDATION**

The Legislature recently clarified the definition of municipal water supply (RCW 90.03.015). Under the authority of RCW 90.03.560, the purpose of use under this permit is now municipal supply since over 15 residences are served. The unperfected portion of this water right is not relinquished because it is a municipal water right.

In accordance with chapters 90.03 and 90.44 RCW, the author makes a tentative determination that Ground Water Permit No. G4-30573P is a valid right and is eligible for change.

Approval of this change as provisioned below will not cause impairment of existing water rights nor enlarge the water right.

Exercising this beneficial use of water at the new source will not be contrary to the public interest.

The proposed well taps the same body of ground water as the original well.

Water is available in the aquifer at the new source.

Based on the above investigation and findings, I recommend that the request to change a point of withdrawal to City of Okanogan Well No. 3 be authorized, subject to the provisions listed below.

**Purpose of Use and Authorized Quantities**

20 gpm for a maximum of 6.3 acre-ft/yr for municipal water supply.

**Point of Withdrawal**

Approximately 1350 feet south and 2080 feet west from the NE corner of Section 9, T. 33 N., R. 26 E.W.M.

**Place of Use**

Sections 4, 5, and 9, T. 33 N., R. 26 E.W.M.

**Construction Schedule**

<b>Begin construction by:</b>	October 1, 2006
<b>Complete construction by:</b>	December 31, 2006
<b>Apply water to full beneficial use by:</b>	December 31, 2007

**Provisions**

If the criteria in RCW 90.03.386(2) are not met, the place of use of this water right reverts to the service area described in the Water System Plan/Small Water System Management Program most recently approved after September 9, 2003. If the criteria in RCW 90.03.386(2) are not met and no WSP/SWSMP has been approved after September 9, 2003, the place of use reverts to the last place of use described by Ecology in a water right authorization.

An approved measuring device shall be installed and maintained for each of the sources identified by this water right in accordance with the rule "Requirements for Measuring and Reporting Water Use", Chapter 173-173 WAC.

Water use data shall be recorded weekly. The maximum rate of withdrawal and the annual total volume shall be submitted to Ecology by January 31<sup>st</sup> of each calendar year.

Chapter 173-173 WAC describes the requirements for data accuracy, device installation and operation, and information reporting. It also allows a water user to petition Ecology for modifications to some of the requirements. Installation, operation and maintenance requirements are enclosed as a document entitled "Water Measurement Device Installation and Operation Requirements".

The following information, including appropriate units of measure, shall be included with each submittal of water use data: owner, contact name if different, mailing address, daytime phone number, WRIA No., Permit No., source name, annual quantity used, maximum rate of withdrawal, Department of Health WFI water system number and source number(s), purpose of use, well tag number, and period of use. In the future, Ecology may require additional parameters to be reported or more frequent reporting. Ecology prefers web based data entry, but does accept hard copies. Ecology will provide forms and electronic data entry information.

Department of Ecology personnel, upon presentation of proper credentials, shall have access at reasonable times, to the records of water use that are kept to meet the above conditions, and to inspect at reasonable times any measuring device used to meet the above conditions.

All water wells constructed within the state shall meet the minimum standards for construction and maintenance as provided under RCW 18.104 (Washington Water Well Construction Act of 1971) and Chapter 173-160 WAC (Minimum Standards for Construction and Maintenance of Water Wells).

Installation and maintenance of an access port as described in Ground Water Bulletin No. 1 is required. An air line and gage may be installed in addition to the access port.

Report by: Virginia Stone  
Virginia Stone, Water Resources Program

7/5/06  
Date

**FINDINGS OF FACT AND DECISION**

Upon reviewing the above report, I find all facts, relevant and material to the subject change application, have been thoroughly investigated. Furthermore, I find water is available for appropriation and the appropriation as recommended is a beneficial use and will not be detrimental to existing rights or the public welfare.

Therefore, I ORDER the requested changes for point of withdrawal and purpose of use under Ground Water Application No. CG4-30273, be approved subject to existing rights and provisions specified in the foregoing report.

Signed at Yakima, Washington, this 10th day of July 2006.

  
G. Thomas Tebb, L.E.G.  
Section Manager  
Water Resources Program  
Central Region Office

000052CL



STATE OF WASHINGTON  
DEPARTMENT OF WATER RESOURCES  
DIVISION OF WATER MANAGEMENT

**WATER RIGHT CLAIM**

RECEIVED  
DEPT. OF WATER RESOURCES  
FEB 24 70000076  
CASH  OTHER  NONE

1. NAME City of Okanogan  
ADDRESS c/o City Clerk  
Okanogan, Washington ZIP CODE 98840

2. SOURCE FROM WHICH THE RIGHT TO TAKE AND MAKE USE OF WATER IS CLAIMED: Surface  
(SURFACE OR GROUND WATER)  
W.R.I.A. 49  
(LEAVE BLANK)

A. IF GROUND WATER, THE SOURCE IS \_\_\_\_\_  
B. IF SURFACE WATER, THE SOURCE IS Springs ("Shull Springs")

3. THE QUANTITIES OF WATER AND TIMES OF USE CLAIMED:  
A. QUANTITY OF WATER CLAIMED 300 g.p.m. (All water) PRESENTLY USED 300 g.p.m. (All water)  
(CUBIC FEET PER SECOND OR GALLONS PER MINUTE)  
B. ANNUAL QUANTITY CLAIMED 484 acre-feet per year PRESENTLY USED 484 acre-feet per year  
(ACRE FEET PER YEAR)  
C. IF FOR IRRIGATION, ACRES CLAIMED \_\_\_\_\_ PRESENTLY IRRIGATED \_\_\_\_\_  
D. TIME(S) DURING EACH YEAR WHEN WATER IS USED: Continuously

4. DATE OF FIRST PUTTING WATER TO USE. MONTH Unknown YEAR 1908

5. LOCATION OF THE POINT(S) OF DIVERSION/WITHDRAWAL: Shull springs-located between a point 1200  
feet west and 800 feet south from the center of Sec. 5 and a point located 100 feet west  
of the SE corner of Sec. 5  
road 350 feet north of the south quarter corner of Sec. 5; Said points  
BEING WITHIN N 2 1/2 W 1/2 S 5 OF SECTION 5 T. 33 N. R. 26 (E 1/4 SW 1/4) W.A.  
See attached map  
IF THIS IS WITHIN THE LIMITS OF A RECORDED PLATTED PROPERTY, LOT \_\_\_\_\_ BLOCK \_\_\_\_\_ OF \_\_\_\_\_

(GIVE NAME OF PLAT OR ADDITION)  
6. LEGAL DESCRIPTION OF LANDS ON WHICH THE WATER IS USED: Within the corporate limits of the  
City of Okanogan, Washington

\_\_\_\_\_ COUNTY Okanogan

7. PURPOSE(S) FOR WHICH WATER IS USED: Municipal water supply

8. THE LEGAL DOCTRINE(S) UPON WHICH THE RIGHT OF CLAIM IS BASED: Appropriation

DO NOT USE THIS SPACE  
THE FILING OF A STATEMENT OF CLAIM DOES NOT CONSTITUTE AN ADJUDICATION OF ANY CLAIM TO THE RIGHT TO USE OF WATER AS BETWEEN THE WATER USE CLAIMANT AND THE STATE OR AS BETWEEN ONE OR MORE WATER USE CLAIMANTS AND ANOTHER OR OTHERS. THIS ACKNOWLEDGEMENT CONSTITUTES RECEIPT FOR FILING FEE.  
DATE RETURNED \_\_\_\_\_ REGISTRY NUMBER \_\_\_\_\_  
FEB 24 70000052  
THIS HAS BEEN ASSIGNED WATER RIGHT CLAIM REGISTRY NO. \_\_\_\_\_  
Assistant Director DIVISION OF WATER MANAGEMENT - DEPARTMENT OF WATER RESOURCES  
John H. Liddle

I HEREBY SWEAR THAT THE ABOVE INFORMATION IS TRUE AND ACCURATE TO THE BEST OF MY KNOWLEDGE AND BELIEF  
X R. E. Johnson  
DATE February 24, 1970  
IF CLAIM FILED BY DESIGNATED REPRESENTATIVE PRINT OF TYPE FULL NAME AND MAILING ADDRESS OF AGENT BELOW  
R. E. Johnson, City Attorney  
Okanogan, Washington 98840  
 ADDITIONAL INFORMATION RELATING TO WATER QUALITY AND OF WELL CONSTRUCTION IS AVAILABLE

A FEE OF \$7.50 MUST ACCOMPANY THIS WATER RIGHT CLAIM  
ORIGINAL  
EWR  
RETURN ALL THREE COPIES WITH LAWRSON'S INITIAL ALONG WITH YOUR FEE TO DEPARTMENT OF WATER RESOURCES, DIVISION OF WATER MANAGEMENT, UNION AVE BUILDING CLYDE WASHINGTON 98901

GWC-03410

*as amended*

PROGRESS SHEET - GROUND WATER APPLICATION

NAME: City of Okanogan  
Okanogan Washington

Assigned to: \_\_\_\_\_

G.W. APPL. NO. 742 PERMIT NO. 4842 CERT. NO. 3410

AMENDED

CANCELLED

Appl. received 2-21-48 Initial \$5.00 fee received 2-21-48  
Statement of Additional Examination Fee \$ \_\_\_\_\_ Sent \_\_\_\_\_  
Received \_\_\_\_\_

Application returned for completion or correction  
Received \_\_\_\_\_

TEMPORARY PERMIT: Approved by \_\_\_\_\_ Issued \_\_\_\_\_

PUBLICATION:

O.K'd by W.B. Date 7-25-48 Notice sent 2-25-48  
Protests filed 5-15-59 new notice sent 5-21-59

Affidavit received and checked 5-18-59 Time Expires 5-11-59

GAME REPORT: \_\_\_\_\_

EXAMINATION:

Made 5-14-59 by W.B.

O.K'd for Permit 6-1-59 by W.B.

Statement of Permit Fee sent 5-20-59 Amount \$ 20.00  
Received 6-8-59

PERMIT NO. 4842 Issued 6-11-59

BEGINNING OF CONSTRUCTION: Notice sent started Filed \_\_\_\_\_  
Extension fee \$ \_\_\_\_\_ Extended to \_\_\_\_\_  
Extended to \_\_\_\_\_

WELL DRILLER'S REPORT: Sent 3-26-59 Filed unfiled

COMPLETION OF CONSTRUCTION: Notice sent completed Filed \_\_\_\_\_  
Time extended to \_\_\_\_\_

COMPLETE APPLICATION OF WATER: Notice sent \_\_\_\_\_ Filed \_\_\_\_\_  
Time extended to \_\_\_\_\_

PROOF OF APPROPRIATION: Sent 6-11-59 Filed 8-7-59

Statement of Certificate Fee sent 6-11-59 Received 8-11-59

CERTIFICATE OF GROUND WATER RIGHT NO. 3410 A Issued 8-13-59



STATE OF WASHINGTON, COUNTY OF Okanogan

Certificate of Ground Water Right

Issued in accordance with the provisions of Chapter 203, Laws of Washington for 1918, and amendments thereto, and the rules and regulations of the State Supervisor of Water Resources thereunder.

This is to Certify That CITY OF OKANOGAN, WASHINGTON

has made proof to the satisfaction of the State Supervisor of Water Resources of Washington, of a right to the use of the ground waters of a well

located within SR1994

Sec. 16, Twp. 33 N., R. 26 E.W. M.

for the purpose of municipal supply

under and subject to provisions contained in Ground Water Permit No. 4842 issued by the State Supervisor of Water Resources and that said right to the use of said ground waters has been perfected in accordance with the laws of Washington, and is hereby confirmed by the State Supervisor of Water Resources of Washington and entered of record in Volume 7 at page 3410-A

that the right hereby confirmed dates from February 21, 1948; that the quantity of ground water under the right hereby confirmed for the purposes aforesaid, is limited to an amount actually beneficially used for said purposes, and shall not exceed 200 gallons per minute; 320 acre-foot per year for municipal supply.

A description of the lands to which such ground water right is appurtenant, and the place where such water is put to beneficial use, is as follows:

City of Okanogan, Okanogan County, Washington.

The right to the use of the ground water aforesaid hereby confirmed is restricted to the lands or place of use herein described, except as provided in Sections 6 and 7, Chapter 122, Laws of 1929.

WITNESS the seal and signature of the State Supervisor of Water Resources after this

13th day of August, 1959.

ENGINEERING DATA

M. Walker State Supervisor of Water Resources

0.5 26



STATE OF WASHINGTON  
DEPARTMENT OF CONSERVATION  
DIVISION OF WATER RESOURCES

Permit to appropriate Public Ground Waters  
of the State of Washington

Book No. 10 of Ground Water Permits, on page 4842 under Application No. 752

CITY OF OKANOGAN, WASHINGTON

is hereby granted a permit to appropriate the following described public ground waters of the State of Washington, subject to existing rights, and to the limitations and provisions set out herein.

Priority date of this permit is February 21, 1948

Source of the proposed ground water appropriation is a well

within \_\_\_\_\_ area, \_\_\_\_\_ sub-area  
\_\_\_\_\_ zone. Name or number of works is \_\_\_\_\_

Quantity of water appropriated shall be limited to the amount which can be beneficially applied and not to exceed 200 gallons per minute; 320 acre-feet per year, to be used for the following purposes: municipal supply

as more definitely set out below.

Location of the well, tunnel, or infiltration trench is 1050 feet west and 320 feet north of center of sec. 16

being within SE1/4, sec. 16, T.11 N., R.26 E., N.M.

county of Okanogan

Use, or uses to which water is to be applied:

For municipal supply: 200 gallons per minute; 320 acre-feet per year,  
to supply City of Okanogan.

For irrigation: \_\_\_\_\_ gallons per minute; \_\_\_\_\_ acre-feet per year,  
for the irrigation of \_\_\_\_\_ acres.

For miscellaneous uses: \_\_\_\_\_ gallons per minute; \_\_\_\_\_ acre-feet per year,  
for \_\_\_\_\_

LEGAL DESCRIPTION OF PROPERTY ON WHICH WATER IS TO BE USED

City of Okanogan, Okanogan County, Washington.



DESCRIPTION OF WORKS FROM WHICH WATER IS TO BE WITHDRAWN

The well will be drilled and have a diameter of 18 inches, and depth of 95 feet.

Description of tunnel or infiltration trench:

(Please read carefully provisions below)

Particular specifications required by the Supervisor of Water Resources for the purpose of preventing waste of public waters:

Construction work shall begin on or before Started  
and shall thereafter be prosecuted with reasonable diligence and completed on or before Completed  
and complete application of water to proposed use shall be made on or before June 1, 1960

Given under my hand and the seal of this office at Olympia, Washington, this 11th day of June, 1959.

[Signature]  
State Supervisor of Water Resources

# Report of Examination on Ground Water

Received date 2-21-58 Date of exam 5-11-59 Appl. No. 742  
Name City of Okanogan Address Okanogan, Wash.  
Type of works well Dimensions 12" x 5'  
Progress of works well completed (march 1958)  
Quantity applied for 200 g.p.m. \_\_\_\_\_ acre-feet per year  
Legal sub. S1/4 Sec. 16 Twp. 13 N. Rge. 26 E. County Okanogan  
Use municipal supply

Irrigation-acreage: Present \_\_\_\_\_ Planned \_\_\_\_\_ Feasible \_\_\_\_\_

Municipal: Population 2500 as of 1970

Industrial \_\_\_\_\_

Time pump will be operated continuously

OK: water rights appurtenant to this land SW Cert 592, G.W. Certificates 265 & 266-D and 369-A.

Proximity to existing works, springs, wells, or streams Okanogan River to the west

Area \_\_\_\_\_ Sub-area \_\_\_\_\_ Zone \_\_\_\_\_

## RECOMMENDATIONS

Approved for 200 g.p.m. 320 acre-feet per year, subject to existing water rights. (1 acre-foot 325,860 gallons.)

The City of Okanogan has the four certificates of water right listed above issued for a total withdrawal rate of 1675 gallons per minute and for an annual quantity of 11,880 acre feet per year.

Therefore, permit will issue for a continuous withdrawal rate of 200 g.p.m. or 320 acre-feet per year which will be supplemental to the above listed certificates.

The applicant will furnish information to this office as to the size and type of equipment installed and the gallons per minute furnished. The size of hole openings and number of sprinklers operated, if such be the case, will give this information.

Signed this 19th day of May, 1959.

*Stuart E. Shumway*  
STUART E. SHUMWAY, Hydrogeologist  
Division of Water Resources



REPORT OF FINDINGS ON GROUND WATER Appl. 742

NAME City of Okanogan

TYPE OF WORKS: Well

Date of Examination March 9, 1948

Dimensions: 12" x 95'

Progress of Works well in - no pump

QUANTITY ~~of water~~

Applied for: 200

g.p.m.

acre feet per year

LOCATION NE $\frac{1}{4}$  of NW $\frac{1}{4}$  of 16-35-26 E.W.M.

USE: municipal

Irrigation- acreage: Present \_\_\_\_\_ Planned \_\_\_\_\_ Feasible \_\_\_\_\_

Municipal: Population 2150 as of \_\_\_\_\_

Industrial: \_\_\_\_\_

Time Pump Will be Operated: \_\_\_\_\_

Other Water Rights of Applicant: \_\_\_\_\_

Proximity to existing works, springs or streams: 500 feet West to Okanogan River

Water Bearing Zone: \_\_\_\_\_

RECOMMENDATIONS

Approved for 200 g.p.m. 162 acre-feet  
per year, subject to existing water rights. (1 acre-foot = 325,960 gallons)

This well for the City of Okanogan is located across the bridge in the Eastern part of town which is part of the Colville Indian Reservation.

The present plan is to use it at 200 g.p.m. for 6 months in the summer so that 162 acre-feet a year will be produced.

Ground Water Application #321, Permit #341 will probably be cancelled as soon as this well is put into satisfactory operation.

Signed this 17th day of March, 1948

Fred B. Roberts  
FRED B. ROBERTS  
Ground Water Geologist

# SPORTS COMPLEX WELL PERMIT



# Confederated Tribes of the Colville Reservation

P.O. Box 150, Nespelem, WA 99155

(509)634-2200

FAX: (509)634-4116

March 8, 2000

# RECEIVED

APR 07 2000

CITY OF OKANOGAN  
P.O. BOX 752  
OKANOGAN, WA 98840

<input checked="" type="checkbox"/>	MAYOR	
<input checked="" type="checkbox"/>	C/TREAS.	
<input checked="" type="checkbox"/>	CITY SUPT.	
<input checked="" type="checkbox"/>	E. CHIEF	
<input checked="" type="checkbox"/>	BLD. INS.	
<input checked="" type="checkbox"/>	PLAN. COM.	
<input checked="" type="checkbox"/>	COUNCIL	
<input checked="" type="checkbox"/>	REC. MGR.	
<input checked="" type="checkbox"/>	ATTORNEY	
<input checked="" type="checkbox"/>	PLANNING	

Ella Schreckengost, Mayor  
City of Okanogan  
P.O. Box 750  
Okanogan, WA. 98840

Re: Permit number 99-06-04-11G.

Dear Mayor,

This letter serves as notice that your pending application to use water on the reservation has been approved.

Within the "Located At" section of your approved permit you will see that I wrote "Notify Water Administrator". To this I would like to add that I will want a copy of the well drillers report when the new well is drilled.

Your application was brought to the Natural Resources Committee on March 6, 2000. If I may assist you with information in the future in regard to water issues of the Colville Tribes, please do not hesitate to contact me. My office number is 634-2200, extension 7212. The Environmental Trust fax number is 634-2427.

Sincerely,

Lois M. Trevino, Water Administrator  
Colville Confederated Tribes

cc: file

SERIAL NUMBER 99-06-04-116

PERMIT TO USE WATERS OF THE  
COLVILLE INDIAN RESERVATION

WHEREAS THE APPLICANT, Ella Schreckengost, Mayor, City of Okanogan  
OF P.O. Box 750,

(Route, Street, or P.O. Box Number)

Okanogan, WA, 98840 HAS  
(City or Town) (State and Zip Code)

REQUESTED PERMISSION TO USE THE WATERS OF THE COLVILLE INDIAN  
RESERVATION; & WHEREAS THE APPLICANT HAS COMPLIED SATISFACTORILY  
WITH THE REGULATIONS OF THE COLVILLE WATER ADMINISTRATOR AND  
COLVILLE WATER COMMITTEE AS SET FORTH IN CHAPTER 6 OF THE COLVILLE  
WATER CODE; AND WHEREAS, THE COLVILLE WATER COMMITTEE HAS  
APPROVED THIS PERMIT APPLICATION, THIS PERMIT NUMBER 99-06-04-116  
THE APPLICANT IS HEREBY GRANTED PERMISSION TO USE 92.31 ACRE-FEET  
OF WATER AT A RATE OF 270 gpm WHICH WILL BE WITHDRAWN/DIVERTED  
FROM a well LOCATED AT Notify Water Administrator  
BY METHOD OF Electric Pump

FOR THE PURPOSE (S) OF Irrigating sports fields.

TO BE USED ON 1650 ft. West, 350 ft. North, Southeast corner of Sec 9,  
SW 4, SE 4, Section 9, T.33N, R.16E.

DURING THE PERIOD OF TIME Annually  
WITH THE FOLLOWING PROVISIONS Permit may be revoked if found  
necessary to protect Okanogan River Fishery.

THIS PERMIT CONSTITUTES TRIBAL PERMISSION TO USE WATERS  
OF THE COLVILLE INDIAN RESERVATION

THIS WATER PERMIT, NUMBER 99-06-04-116 WAS PRESENTED TO THE  
NATURAL RESOURCES COMMITTEE AND Approved ON March 6, 2000  
BY A VOTE OF Five FOR AND Zero AGAINST.

ATTEST:

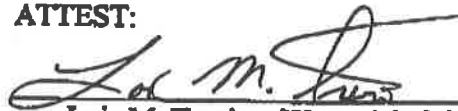

Lois M. Trevino, Water Administrator

REMARKS: Approved by Water Administrator per 37.73 of the Colville Water Code.  
Per 37.74 applicant consents to entry upon land for purposes relating to Colville Water Code.

Water use unauthorized without permittee's consent to Department officials to enter upon land  
for the purposes set forth in the Water Code (CTC 37.74).

COLVILLE CONFEDERATED TRIBES  
Environmental Trust Department  
P.O. Box 150  
Nespelem, WA 99155-0150

(509) 634-2425 (office)  
(509) 634-2427 (fax)  
lmerita@televar.com



# JUSTMENT KSON

## LEGAL DESCRIPTION

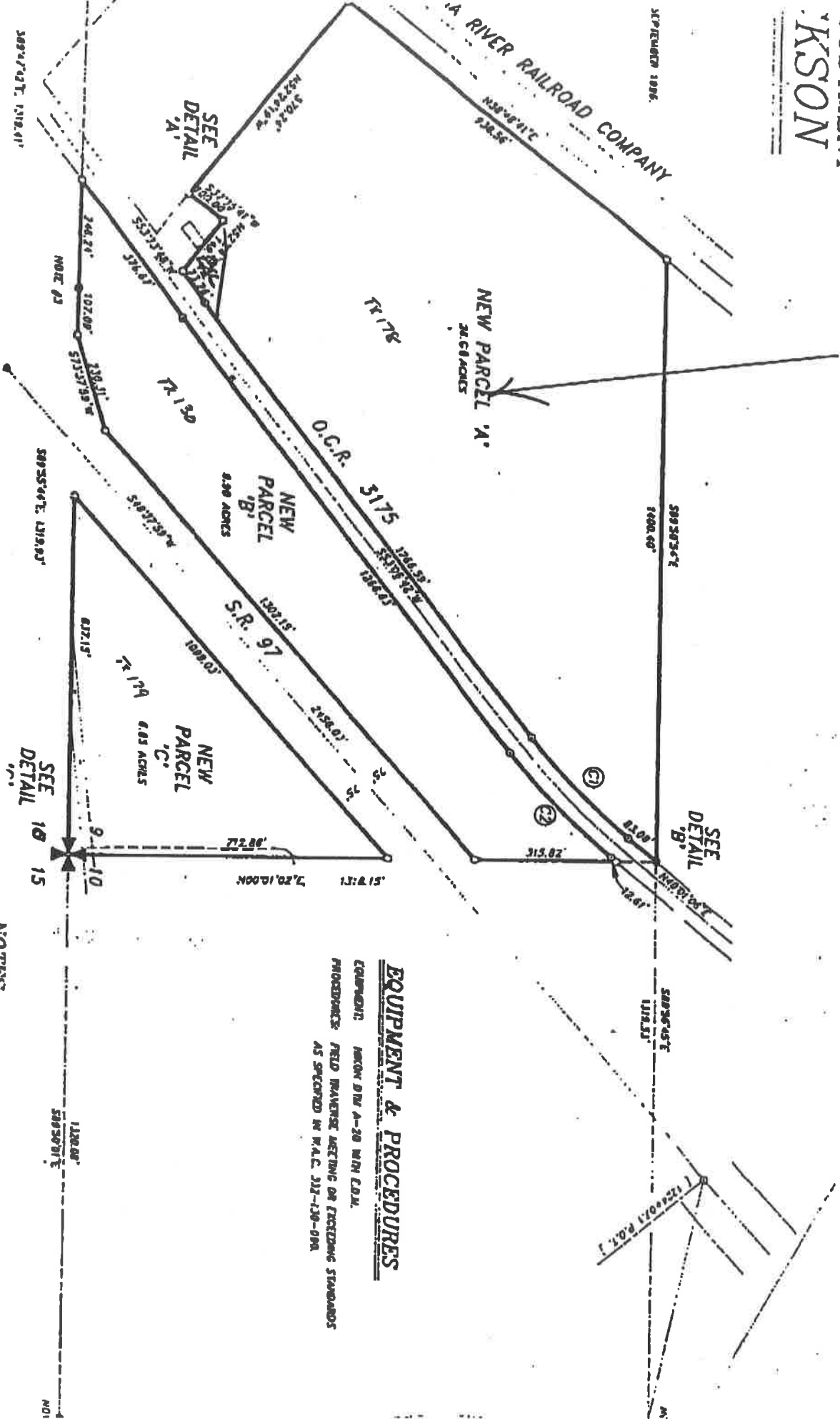

This sketch is provided, without charge, for your information. It is not intended to show all matters related to the property including, but not limited to, area dimensions, easements, encroachments, or location of boundaries. It is not a part of, nor does it modify, the contract or policy to which it is attached. The Company assumes no liability for any matters related to this sketch. Reference should be made to an accurate survey for further information.

### EQUIPMENT & PROCEDURES

EQUIPMENT: HICON DTM A-30 WITH EDM.  
 PROCEDURES: FIELD TRAVERSE METHOD OF EXCEEDING STANDARDS  
 AS SPECIFIED IN N.A.C. 212-120-09A

### NOTES

**COLVILLE CONFEDERATED TRIBES**  
Nespelem, Washington

March 6, 2000

TO: COLVILLE BUSINESS COUNCIL  
FROM: Natural Resource Committee  
SUBJECT: Approve application number 99-06-04-11G.

Initiated by: \_\_\_\_\_ Program: \_\_\_\_\_

Committee Recommendations

Approve Serial Number 99-06-04-11G, Permit To Use Waters Of The Colville Indian Reservation with the following provision: This water will not be co-mingled with the City of Okanogan municipal water system.

The Tribes reserves the right to restrict this withdrawal of water to protect the Okanogan fishery in the event "minimum instream flows" are not being met.

The minimum flows for the lower Okanogan as measured at the state guage near Mallot shall apply to this permit as minimum instream flows until such time as they are revised as required to protect the fishery.

Approve the amount of water use to be set at 85 acre feet.

<u>COMMITTEE MEMBERS</u>	<u>VOTE CAST</u>		<u>COMMITTEE MEMBERS</u>	<u>VOTE CAST</u>	
	(YES)	(NO)		(YES)	(NO)
<u><i>Dell Laine</i></u>	<input checked="" type="checkbox"/>	_____	_____	_____	_____
<u><i>Gene Joseph</i></u>	<input checked="" type="checkbox"/>	_____	_____	_____	_____
<u><i>Matthew Ross</i></u>	<input checked="" type="checkbox"/>	_____	_____	_____	_____
<u><i>Margie Hutchinson</i></u>	<input checked="" type="checkbox"/>	_____	_____	_____	_____
_____	_____	_____	_____	_____	_____
_____	_____	_____	_____	_____	_____
_____	_____	_____	_____	_____	_____

Business Council Actions:

Seconded by: \_\_\_\_\_

\_\_\_ FOR \_\_\_\_\_

Signed: \_\_\_\_\_

\_\_\_ NAY \_\_\_\_\_

Signed: \_\_\_\_\_

\_\_\_ ABSTAINED \_\_\_\_\_

Date Enacted: \_\_\_\_\_

*Dell Laine*  
Committee Chairperson

\_\_\_\_\_  
CBC Chairperson

Amendments: \_\_\_\_\_

Emergency (10 Affirmative Signatures): Rationale attached: \_\_\_\_\_

APPLICATION FOR PERMIT TO USE WATER  
OF THE  
COLVILLE INDIAN RESERVATION

1. (Print or Type) I, Ella Schreckengost, Mayor, City of Okanogan, Box of 750, Okanogan, WA 98840, (509) 422-3600  
(Address - Street #, Box #, City or Town, State, Zip Code, & Telephone)  
Apply for a permit to use waters of the Colville Indian Reservation, as hereinafter stated. (If applicant is a corporation, give date and place of incorporation; if a co-partnership or association give names of members.) City of Okanogan is a municipal corporation organized under the laws of the State of Washington.
2. The source of water is (name of stream, lake, spring, groundwater or other source.) Okanogan River - and ground water in hydraulic continuity therewith.
3. The quantity of water which is to be diverted from surface water or withdrawn as ground water: up to 100 acre feet per year
4. Peak use expected (gallons/minute or cubic feet/second): up to 600 gallons per minute
5. Total volume of water used per year in acre-feet (one acre foot = 43560 cubic foot) up to 100 acre feet per year
6. Use will begin about (day/month) April 1 annually  
and end about (day/month) October 31 annually
7. If stored in a reservoir or large tank give number of acre-feet or gallons N/A
8. The purpose(s) for which the water is to be used is (see instructions):  
Irrigation of park land and athletic fields and ultimate incorporation into City's municipal water system.
9. Describe the works to be used in diverting and/or withdrawing, transmitting and applying water. (State manner in which water is to be diverted, whether by dam or other works, whether through pipes, ditches, flumes, etc. and type and HP of pumps, if used; and type of sprinkling, drip, furrow or other irrigation used. Attach maps, plans, & diagrams if necessary). Applicant requests change of point of diversion of surface water to point of withdrawal from existing well on subject property. Existing well has not yet been tested.

CCT ENROLLMENT #  
TRUST LAND / FEE LAND  
LEASED: YES / NO  
LEASE EXPIRATION DATE:

Colville Confederated Tribes  
Environmental Trust (509)634-8844  
Post Office 150  
Nespelem, WA 99155

10. The water is to be diverted or withdrawn from the above source at the following point (Describe as being within the smallest legal subdivision of public survey, and by direction and distance to a section corner):

Legal Description	SEC	TWP	RGE
SW $\frac{1}{4}$ of SE $\frac{1}{4}$	9	33	26

1650 ft. N S E (W) and 350 ft. (N) S E W of the ~~N S E W~~ (Circle One) (Circle One) (Circle One) quarter corner or NE NW (SE) SW corner of SEC 9 TWP 33 RGE 26 (whichever location applies).

11. The legal description of the property on which the water is to be used is (Describe as being within the smallest legal subdivision):

Legal Description	SEC	TWP	RGE
See attached Exhibit A			

(Attach additional pages if necessary)

12. Construction of water diversion, transmission, and/or withdrawal works will commence on or about August, 1999, and end on or about March 31, 2000. Use of water will begin on or about October, 1999.

13. Include remarks below or on additional sheets as required for the following: If a use is an existing use describe the history of the use, including the names of any predecessors in title and the dates of their ownership, if known, and their uses of water. If any pre-existing right is claimed, describe any documents or records upon which it is based, any statute or statutes or legal doctrine upon which the claim is based, and any pertinent litigation creating or affecting the claim. If a pre-existing use or uses are described, indicate any problems of water levels and supply or problems of declining quality that have been encountered in the past. REMARKS: The property was acquired by the applicant from Warren Dickson in 1998, together with a portion of federally reserved water right. Water has historically been used continuously for irrigation since land came out of trust status (former Allotment S-240). See attachments.

14. Describe your plans for future development of your water use or uses and related activities. Water is to be used for irrigation of park land and athletic fields initially, ultimately to be integrated into the City's municipal water system.

*Ella Shindler* 1-1-99  
 OKANOGAN COUNTY PM 15:18 NOV-27-2007



**APPENDIX L**  
**COST ESTIMATES**



City of Okanogan					
(September 2015 ENR National Construction Cost Index #10406)					
G&O #15012					
No.	Item	Quantity	Unit	Unit Price	Amount
1	Water Rights Consolidation	1	LS	\$10,000	\$10,000
1	Telemetry System	1	LS	\$60,000	\$60,000
<b>Watercress Springs Feasibility Study</b>					
1	Feasibility Study	1	LS	\$5,000	\$5,000
2	Source Facilities Inspection	1	LS	\$5,000	\$5,000
3	Pipeline Video Inspection	1	LS	\$5,000	\$5,000
Construction Subtotal					\$15,000
					<b>ROUNDED</b>
					<b>\$15,000</b>
<b>Well Improvements</b>					
1	Mobilization and Demobilization	1	LS	\$20,000	\$20,000
2	Well No. 2	1	LS	\$12,000	\$12,000
3	Well No. 3	1	LS	\$14,000	\$14,000
4	Well No. 4	1	LS	\$25,000	\$25,000
5	Well No. 5	1	LS	\$82,000	\$82,000
Construction Subtotal					\$153,000
Contingency (25%, rounded)					\$38,300
Sales Tax (8.2%, rounded))					\$15,700
Design/CA Services (25%, rounded))					\$38,300
Total Estimated Project Cost					\$245,300
					<b>ROUNDED</b>
					<b>\$246,000</b>
<b>Well Decommissioning</b>					
1	Mobilization and Demobilization	1	LS	\$20,000	\$20,000
2	Temporary Erosion Control	2	LS	\$5,000	\$10,000
3	SPCC Plan	2	LS	\$1,000	\$2,000
4	Downhole Television Inspection	2	EA	\$2,000	\$4,000
5	Concrete Sealant	50	CY	\$750	\$37,500
6	Old Well No. 1 Decommissioning	1	LS	\$20,000	\$20,000
7	Old Well No. 4 Decommissioning	1	LS	\$20,000	\$20,000
8	Sports Complex Well Decommissioning	1	LS	\$20,000	\$20,000
9	Surface Restoration	1	LS	\$5,000	\$5,000
Construction Subtotal					\$138,500
Contingency (25%, rounded)					\$34,600
Sales Tax (8.2%, rounded))					\$14,200
Design/CA Services (25%, rounded))					\$34,600
Total Estimated Project Cost					\$221,900
					<b>ROUNDED</b>
					<b>\$222,000</b>
<b>Well No. 3 Inspection</b>					
1	Mobilization and Demobilization	1	LS	\$10,000	\$10,000
2	Remove pump, motor and piping	1	LS	\$5,000	\$5,000
3	Downhole Video Inspection	1	LS	\$2,000	\$2,000
4	Reinstall pump, motor and piping	1	LS	\$5,000	\$5,000
Construction Subtotal					\$22,000
Contingency (25%, rounded)					\$5,500
Sales Tax (8.2%, rounded))					\$2,300
Design/CA Services (25%, rounded))					\$5,500
Total Estimated Project Cost					\$35,300
					<b>ROUNDED</b>
					<b>\$36,000</b>

City of Okanogan					
(September 2015 ENR National Construction Cost Index #10406)					
G&O #15012					
No.	Item	Quantity	Unit	Unit Price	Amount
<b>Well No. 4 Bypass</b>					
1	Bypass Piping	1	LS	\$15,000	\$15,000
2	Surface Restoration	1	LS	\$2,000	\$2,000
				Construction Subtotal	\$17,000
				Contingency (25%, rounded)	\$4,300
				Sales Tax (8.2%, rounded))	\$1,700
				Design/CA Services (25%, rounded))	\$4,300
				Total Estimated Project Cost	\$27,300
				<b>ROUNDED</b>	<b>\$28,000</b>
<b>Arsenic Treatment Facility Improvements</b>					
1	Mobilization and Demobilization	1	LS	\$5,000	\$5,000
2	Sludge Drying Beds	1	LS	\$25,000	\$25,000
				Construction Subtotal	\$30,000
				Contingency (25%, rounded)	\$7,500
				Sales Tax (8.2%, rounded))	\$3,100
				Design/CA Services (25%, rounded))	\$7,500
				Total Estimated Project Cost	\$48,100
				<b>ROUNDED</b>	<b>\$50,000</b>

City of Okanogan					
Murray Street Master Meter					
(September 2015 ENR National Construction Cost Index #10406)					
G&O #15012					
No.	Item	Quantity	Unit	Unit Price	Amount
1	Mobilization and Demobilization	1	LS	\$10,000	\$10,000
2	Demolish Building	1	LS	\$5,000	\$5,000
3	Meter Vault	1	LS	\$15,000	\$15,000
4	Piping and Appurtenances	1	LS	\$5,000	\$5,000
5	Surface Restoration	1	LS	\$2,000	\$2,000
				Construction Subtotal	\$37,000
				Contingency (25%, rounded)	\$9,300
				Sales Tax (8.2%, rounded))	\$3,800
				Design/CA Services (25%, rounded))	\$9,300
				<b>Total Estimated Project Cost</b>	<b>\$59,400</b>
				<b>ROUNDED</b>	<b>\$60,000</b>

City of Okanogan					
Murray Street Booster Pump Station					
(September 2015 ENR National Construction Cost Index #10406)					
G&O #15012					
No.	Item	Quantity	Unit	Unit Price	Amount
1	Mobilization and Demobilization	1	LS	\$30,000	\$30,000
2	Trench Excavation Safety Systems	1	LS	\$2,000	\$2,000
3	Temporary Erosion Control	1	LS	\$2,000	\$2,000
4	Traffic Control	1	LS	\$2,000	\$2,000
5	SPCC Plan	1	LS	\$1,000	\$1,000
6	Foundation Material	5	CY	\$25	\$125
7	Bank Run Gravel for Trench Backfill	50	CY	\$25	\$1,250
8	Site Piping	1	LS	\$5,000	\$5,000
9	Booster Pumping Station	1	LS	\$75,000	\$75,000
10	Butterfly Valve 12-Inch	4	EA	\$3,000	\$12,000
11	Water Main Fittings	1	LS	\$10,000	\$10,000
12	Additional Water Main Fittings	1,000	LB	\$3	\$3,000
13	Additional Concrete Thrust Block	10	CY	\$100	\$1,000
14	Connect to Existing System	2	EA	\$2,000	\$4,000
15	Electrical w/Building	1	LS	\$120,000	\$120,000
16	Crushed Surfacing Top Course	30	TN	\$25	\$750
17	HMA for Pavement Repair Cl. 1/2" PG 64-28	200	SY	\$60	\$12,000
18	Site Restoration and Rehabilitation	1	LS	\$10,000	\$10,000
				Construction Subtotal	\$291,125
				Contingency (25%, rounded)	\$72,800
				Sales Tax (8.2%, rounded))	\$29,800
				Design/CA Services (25%, rounded))	\$72,800
				<b>Total Estimated Project Cost</b>	<b>\$466,525</b>
				<b>ROUNDED</b>	<b>\$467,000</b>

**City of Okanogan**

**5th Avenue Water Main Replacement - Spruce St. to Oak St.  
(September 2015 ENR National Construction Cost Index #10406)**

**G&O #15012**

No.	Item	Quantity	Unit	Unit Price	Amount
1	Mobilization and Demobilization	1	LS	\$30,000	\$30,000
2	Trench Excavation Safety Systems	1	LS	\$5,000	\$5,000
3	Temporary Erosion Control	1	LS	\$2,000	\$2,000
4	Traffic Control	1	LS	\$5,000	\$5,000
5	SPCC Plan	1	LS	\$1,000	\$1,000
6	Foundation Material	20	CY	\$25	\$500
7	Bank Run Gravel for Trench Backfill	200	CY	\$25	\$5,000
8	DI Pipe for Water Main 12-Inch Diameter, Including Bedding Material	100	LF	\$70	\$7,000
9	PVC Pipe for Water Main 12-Inch Diameter, Including Bedding Material	1,200	LF	\$50	\$60,000
10	PVC Pipe for Water Main 8-Inch Diameter, Including Bedding Material	150	LF	\$40	\$6,000
11	DI Pipe for Fire Hydrant 6-Inch Diameter, Including Bedding Material	100	LF	\$40	\$4,000
12	Butterfly Valve 12-Inch	4	EA	\$3,000	\$12,000
13	Gate Valve 8-Inch	3	EA	\$1,500	\$4,500
14	Fire Hydrant Assembly	3	EA	\$4,000	\$12,000
15	Water Main Fittings	1	LS	\$10,000	\$10,000
16	Additional Water Main Fittings	2,000	LB	\$3	\$6,000
17	Additional Concrete Thrust Block	10	CY	\$100	\$1,000
18	Connect to Existing System	5	EA	\$2,000	\$10,000
19	Service Connection 1-Inch Diameter	10	EA	\$1,000	\$10,000
20	Service Pipe 2-Inch Diameter, Including Bedding Material	200	LF	\$25	\$5,000
21	Service Pipe 1-Inch Diameter, Including Bedding Material	200	LF	\$20	\$4,000
22	Crushed Surfacing Top Course	100	TN	\$25	\$2,500
23	HMA for Pavement Repair Cl. 1/2" PG 64-28	1,300	SY	\$60	\$78,000
24	Site Restoration and Rehabilitation	1	LS	\$10,000	\$10,000
				<b>Construction Subtotal</b>	<b>\$290,500</b>
				<b>Contingency (25%, rounded)</b>	<b>\$72,600</b>
				<b>Sales Tax (8.2%, rounded))</b>	<b>\$29,800</b>
				<b>Design/CA Services (25%, rounded))</b>	<b>\$72,600</b>
				<b>Total Estimated Project Cost</b>	<b>\$465,500</b>
				<b>ROUNDED</b>	<b>\$466,000</b>

**City of Okanogan**

**Elmway Water Main Extension Phase 3 - River St. to Shell Rock Point**

**(September 2015 ENR Seattle Construction Cost Index #10406)**

**G&O #15012**

No.	Item	Quantity	Unit	Unit Price	Amount
1	Mobilization and Demobilization	1	LS	\$50,000	\$50,000
2	Trench Excavation Safety Systems	1	LS	\$8,000	\$8,000
3	Temporary Erosion Control	1	LS	\$5,000	\$5,000
4	Traffic Control	1	LS	\$15,000	\$15,000
5	SPCC Plan	1	LS	\$1,000	\$1,000
6	Foundation Material	40	CY	\$25	\$1,000
7	Bank Run Gravel for Trench Backfill	300	CY	\$25	\$7,500
8	Casing Pipe 20-Inch Diameter - Elgin Creek	40	LF	\$600	\$24,000
9	PVC Pipe for Water Main 12-Inch Diameter, Including Bedding Material	3,430	LF	\$50	\$171,500
10	PVC Pipe for Water Main 8-Inch Diameter, Including Bedding Material	20	LF	\$40	\$800
11	DI Pipe for Fire Hydrant 6-Inch Diameter, Including Bedding Material	100	LF	\$40	\$4,000
12	Butterfly Valve 12-Inch	4	EA	\$3,000	\$12,000
13	Gate Valve 8-Inch	1	EA	\$1,500	\$1,500
14	Fire Hydrant Assembly	9	EA	\$4,000	\$36,000
15	Water Main Fittings	1	LS	\$15,000	\$15,000
16	Additional Water Main Fittings	2,000	LB	\$3	\$6,000
17	Additional Concrete Thrust Block	10	CY	\$100	\$1,000
18	Connect to Existing System	1	EA	\$2,000	\$2,000
19	Crushed Surfacing Top Course	225	TN	\$25	\$5,625
20	HMA for Pavement Repair Cl. 1/2" PG 64-28	1,600	SY	\$100	\$160,000
21	Site Restoration and Rehabilitation	1	LS	\$20,000	\$20,000
				Construction Subtotal	\$546,925
				Contingency (25%)	\$136,731
				Sales Tax (8.2%)	\$56,060
				Design/CA Services (25%)	\$136,731
				<b>Total Estimated Project Cost</b>	<b>\$876,447</b>
				<b>ROUNDED</b>	<b>\$877,000</b>

**City of Okanogan**

**1st Avenue Water Main - Ione St. to Tye St.**

**(September 2015 ENR Seattle Construction Cost Index #10406)**

**G&O #15012**

No.	Item	Quantity	Unit	Unit Price	Amount
1	Mobilization and Demobilization	1	LS	\$80,000	\$80,000
2	Trench Excavation Safety Systems	1	LS	\$10,000	\$10,000
3	Temporary Erosion Control	1	LS	\$5,000	\$5,000
4	Traffic Control	1	LS	\$10,000	\$10,000
5	SPCC Plan	1	LS	\$1,000	\$1,000
6	Foundation Material	50	CY	\$25	\$1,250
7	Bank Run Gravel for Trench Backfill	300	CY	\$25	\$7,500
8	Casing Pipe 20-Inch Diameter - Creek Crossing	60	LF	\$600	\$36,000
9	PVC Pipe for Water Main 8-Inch Diameter, Including Bedding Material	4,200	LF	\$40	\$168,000
10	DI Pipe for Fire Hydrant 6-Inch Diameter, Including Bedding Material	400	LF	\$40	\$16,000
11	Butterfly Valve 12-Inch	2	EA	\$3,000	\$6,000
12	Gate Valve 8-Inch	13	EA	\$1,500	\$19,500
13	Fire Hydrant Assembly	10	EA	\$4,000	\$40,000
14	Water Main Fittings	1	LS	\$15,000	\$15,000
15	Additional Water Main Fittings	2,000	LB	\$3	\$6,000
16	Additional Concrete Thrust Block	10	CY	\$100	\$1,000
17	Connect to Existing System	6	EA	\$2,000	\$12,000
18	Service Connection 1-Inch Diameter	80	EA	\$1,000	\$80,000
19	Service Pipe 1-Inch Diameter, Including	4,000	LF	\$20	\$80,000
20	Crushed Surfacing Top Course	400	TN	\$25	\$10,000
21	HMA for Pavement Repair Cl. 1/2" PG 64-28	4,100	SY	\$60	\$246,000
22	Site Restoration and Rehabilitation	1	LS	\$20,000	\$20,000
				Construction Subtotal	\$870,250
				Contingency (25%)	\$217,563
				Sales Tax (8.2%)	\$89,201
				Design/CA Services (25%)	\$217,563
				<b>Total Estimated Project Cost</b>	<b>\$1,394,576</b>
				<b>ROUNDED</b>	<b>\$1,395,000</b>

City of Okanogan					
South Okanogan Water System Improvements					
(September 2015 ENR Seattle Construction Cost Index #10406)					
G&O #15012					
No.	Item	Quantity	Unit	Unit Price	Amount
1	Mobilization and Demobilization	1	LS	\$70,000	\$70,000
2	Trench Excavation Safety Systems	1	LS	\$10,000	\$10,000
3	Temporary Erosion Control	1	LS	\$5,000	\$5,000
4	Traffic Control	1	LS	\$15,000	\$15,000
5	SPCC Plan	1	LS	\$1,000	\$1,000
6	Foundation Material	40	CY	\$25	\$1,000
7	Bank Run Gravel for Trench Backfill	220	CY	\$25	\$5,500
8	PVC Pipe for Water Main 12-Inch Diameter, Including Bedding Material	900	LF	\$50	\$45,000
9	PVC Pipe for Water Main 8-Inch Diameter, Including Bedding Material	2,400	LF	\$40	\$96,000
10	DI Pipe for Fire Hydrant 6-Inch Diameter, Including Bedding Material	440	LF	\$40	\$17,600
11	Butterfly Valve 12-Inch	4	EA	\$3,000	\$12,000
12	Gate Valve 8-Inch	8	EA	\$1,500	\$12,000
13	Fire Hydrant Assembly	11	EA	\$4,000	\$44,000
14	Water Main Fittings	1	LS	\$10,000	\$10,000
15	Additional Water Main Fittings	1,000	LB	\$3	\$3,000
16	Additional Concrete Thrust Block	10	CY	\$100	\$1,000
17	Connect to Existing System	5	EA	\$2,000	\$10,000
18	Service Connection 1-Inch Diameter	50	EA	\$1,000	\$50,000
19	Service Pipe 1-Inch Diameter, Including	2,500	LF	\$20	\$50,000
20	Crushed Surfacing Top Course	250	TN	\$25	\$6,250
21	HMA for Pavement Repair Cl. 1/2" PG 64-28	3,000	SY	\$70	\$210,000
22	Site Restoration and Rehabilitation	1	LS	\$10,000	\$10,000
				Construction Subtotal	\$684,350
				Contingency (25%)	\$171,088
				Sales Tax (8.2%)	\$70,146
				Design/CA Services (25%)	\$171,088
				<b>Total Estimated Project Cost</b>	<b>\$1,096,671</b>
				<b>ROUNDED</b>	<b>\$1,097,000</b>



City of Okanogan					
Rodeo Trail Water Main Replacement					
(September 2015 ENR Seattle Construction Cost Index #10406)					
G&O #15012					
No.	Item	Quantity	Unit	Unit Price	Amount
1	Mobilization and Demobilization	1	LS	\$50,000	\$50,000
2	Trench Excavation Safety Systems	1	LS	\$5,000	\$5,000
3	Temporary Erosion Control	1	LS	\$2,500	\$2,500
4	Traffic Control	1	LS	\$10,000	\$10,000
5	SPCC Plan	1	LS	\$1,000	\$1,000
6	Foundation Material	40	CY	\$25	\$1,000
7	Bank Run Gravel for Trench Backfill	200	CY	\$25	\$5,000
8	PVC Pipe for Water Main 12-Inch Diameter, Including Bedding Material	3,000	LF	\$50	\$150,000
9	DI Pipe for Fire Hydrant 6-Inch Diameter, Including Bedding Material	160	LF	\$40	\$6,400
10	Butterfly Valve 12-Inch	3	EA	\$3,000	\$9,000
11	Gate Valve 8-Inch	1	EA	\$1,500	\$1,500
12	Fire Hydrant Assembly	5	EA	\$4,000	\$20,000
13	Water Main Fittings	1	LS	\$10,000	\$10,000
14	Additional Water Main Fittings	1,000	LB	\$3	\$3,000
15	Additional Concrete Thrust Block	5	CY	\$100	\$500
16	Connect to Existing System	1	EA	\$2,000	\$2,000
17	Service Connection 1-Inch Diameter	6	EA	\$1,000	\$6,000
18	Service Pipe 1-Inch Diameter, Including	300	LF	\$20	\$6,000
19	Crushed Surfacing Top Course	200	TN	\$25	\$5,000
20	HMA for Pavement Repair Cl. 1/2" PG 64-28	2,600	SY	\$60	\$156,000
21	Site Restoration and Rehabilitation	1	LS	\$5,000	\$5,000
				Construction Subtotal	\$454,900
				Contingency (25%)	\$113,725
				Sales Tax (8.2%)	\$46,627
				Design/CA Services (25%)	\$113,725
				<b>Total Estimated Project Cost</b>	<b>\$728,977</b>
				<b>ROUNDED</b>	<b>\$729,000</b>

City of Okanogan					
Highland Drive Water Main Replacement					
(September 2015 ENR Seattle Construction Cost Index #10406)					
G&O #15012					
No.	Item	Quantity	Unit	Unit Price	Amount
1	Mobilization and Demobilization	1	LS	\$20,000	\$20,000
2	Trench Excavation Safety Systems	1	LS	\$5,000	\$5,000
3	Temporary Erosion Control	1	LS	\$2,500	\$2,500
4	Traffic Control	1	LS	\$5,000	\$5,000
5	SPCC Plan	1	LS	\$1,000	\$1,000
6	Foundation Material	10	CY	\$25	\$250
7	Bank Run Gravel for Trench Backfill	50	CY	\$25	\$1,250
8	PVC Pipe for Water Main 8-Inch Diameter, Including Bedding Material	800	LF	\$40	\$32,000
9	Gate Valve 8-Inch	4	EA	\$1,500	\$6,000
10	Water Main Fittings	1	LS	\$3,000	\$3,000
11	Additional Water Main Fittings	1,000	LB	\$3	\$3,000
12	Additional Concrete Thrust Block	5	CY	\$100	\$500
13	Connect to Existing System	2	EA	\$2,000	\$4,000
14	Service Connection 1-Inch Diameter	12	EA	\$1,000	\$12,000
15	Service Pipe 1-Inch Diameter, Including	600	LF	\$20	\$12,000
16	Crushed Surfacing Top Course	150	TN	\$25	\$3,750
17	HMA for Pavement Repair Cl. 1/2" PG 64-28	450	SY	\$60	\$27,000
18	Site Restoration and Rehabilitation	1	LS	\$1,000	\$1,000
				Construction Subtotal	\$139,250
				Contingency (25%)	\$34,813
				Sales Tax (8.2%)	\$14,273
				Design/CA Services (25%)	\$34,813
				<b>Total Estimated Project Cost</b>	<b>\$223,148</b>
				<b>ROUNDED</b>	<b>\$224,000</b>

City of Okanogan					
Tacoma Street/Spokane Street Water Main Loop					
(September 2015 ENR Seattle Construction Cost Index #10406)					
G&O #15012					
No.	Item	Quantity	Unit	Unit Price	Amount
1	Mobilization and Demobilization	1	LS	\$40,000	\$40,000
2	Trench Excavation Safety Systems	1	LS	\$5,000	\$5,000
3	Temporary Erosion Control	1	LS	\$5,000	\$5,000
4	Traffic Control	1	LS	\$5,000	\$5,000
5	SPCC Plan	1	LS	\$1,000	\$1,000
6	Foundation Material	20	CY	\$25	\$500
7	Bank Run Gravel for Trench Backfill	100	CY	\$25	\$2,500
8	PVC Pipe for Water Main 8-Inch Diameter, Including Bedding Material	1,800	LF	\$40	\$72,000
9	DI Pipe for Fire Hydrant 6-Inch Diameter, Including Bedding Material	200	LF	\$40	\$8,000
10	Butterfly Valve 12-Inch	4	EA	\$3,000	\$12,000
11	Gate Valve 8-Inch	16	EA	\$1,500	\$24,000
12	Fire Hydrant Assembly	5	EA	\$4,000	\$20,000
13	Water Main Fittings	1	LS	\$10,000	\$10,000
14	Additional Water Main Fittings	1,000	LB	\$3	\$3,000
15	Additional Concrete Thrust Block	5	CY	\$100	\$500
16	Connect to Existing System	5	EA	\$2,000	\$10,000
17	Service Connection 1-Inch Diameter	30	EA	\$1,000	\$30,000
18	Service Pipe 1-Inch Diameter, Including	1,500	LF	\$20	\$30,000
19	Crushed Surfacing Top Course	150	TN	\$25	\$3,750
20	HMA for Pavement Repair Cl. 1/2" PG 64-28	1,600	SY	\$60	\$96,000
21	Site Restoration and Rehabilitation	1	LS	\$10,000	\$10,000
				Construction Subtotal	\$388,250
				Contingency (25%)	\$97,063
				Sales Tax (8.2%)	\$39,796
				Design/CA Services (25%)	\$97,063
				<b>Total Estimated Project Cost</b>	<b>\$622,171</b>
				<b>ROUNDED</b>	<b>\$623,000</b>

**APPENDIX M**  
**AGREEMENT WITH PFWA**

**CITY OF OKANOGAN**  
**AGREEMENT BETWEEN THE CITY OF OKANOGAN AND  
PROGRESSIVE FLAT WATER ASSOCIATION FOR DELIVERY OF  
WATER**

**RECITALS**

1. The Progressive Flat Water Association, hereinafter (Progressive), is a water district formed in 1960 pursuant to the Revised Codes of Washington and is operated as a non-profit corporation under Washington law.

2. Progressive currently provides domestic water service to 45 residences and is authorized to provide domestic water service to 90 residences in the service area described on Exhibit A. The maximum number of services may be increased by the Washington State Department of Health once system upgrades are completed in the service area.

3. The City of Okanogan, Washington, hereinafter (City) is a Washington municipal corporation and operates a water system providing domestic water service to residents within the corporate boundaries of the City.

4. In the past two years the well supplying water to Progressive's water users has been unable to supply sufficient quantity of water to meet domestic needs of its water users, and the water has been determined to have radioactive properties which may prove to be inimical to human health if ingested over long periods of time.

5. Progressive Flats has successfully transferred two water rights to the City of Okanogan, specifically, Water Right Application Number CG4-CWC3838-A@2 for 50 gallons per minute and 39 Acre Feet per year approved on June 7, 2006 and Water Right Number CG4-30573 for 20 gallons per minute and 6.3 Acre Feet per year approved on July 5, 2006.

6. The City is agreeable to providing water from its system to Progressive for domestic use by Progressive's members in exchange for Progressive conveying its water rights to the City and according to the terms and conditions of the following:

**AGREEMENT FOR DELIVERY AND USE OF  
CITY WATER**

The parties herein, PROGRESSIVE FLAT WATER ASSOCIATION and CITY OF OKANOGAN, Washington, for and in consideration of conveyance by PROGRESSIVE to CITY of all it's Water Rights as confirmed by the DEPARTMENT OF ECOLOGY of the

---

State of WASHINGTON, the mutual promises of the parties herein, and other good and valuable consideration, do this 14~~th~~ day of November, 2006 agree as follows:

I.

1.1 The City agrees to furnish water through the City's water system to Progressive for the domestic use of a maximum of 90 individual hookups (or such other maximum number of hookups as may be approved by the Washington State Department of Health and Department of Ecology) to Progressive's water system until such time as any part of the area serviced by Progressive should be annexed to the City and subject to the conditions of annexation as described elsewhere herein. Should annexation of any part of the service area occur, the approved number of hookups permissible shall be reduced by the number of hookups within the annexed service area.

1.2 Progressive asserts and confirms that it has obtained all necessary rights of way and/or easements necessary for the installation and/or continued operation of Progressive's domestic water delivery system and Progressive will maintain said system at no expense to the City. It is agreed that the dividing point between the Progressive Flats System and the City of Okanogan's Water System will be immediately after the master meter and backflow prevention valve on the main line.

1.3 The service connection for each of the hookups referenced above shall have a maximum pipe size of three quarters (3/4) inch in diameter for a single family residential unit, and a maximum pipe size of two (2) inches in diameter for multiple unit housing facilities.

1.4 Progressive agrees that any meters installed in their system will be the same type and brand of meter that is used by the City of Okanogan, and will be suitable for installation of "radio read meter transmitters" that will be compatible with equipment to be acquired by the City of Okanogan. Progressive further agrees that meters will be installed within 10 to 15 feet of the water main which serves the meter.

1.5 The water delivered by the City to Progressive is for domestic use of its members and shall be used exclusively for domestic and non-commercial livestock watering purposes. Water may also be used for farm labor housing facilities and commercial facilities but not for agricultural irrigation or commercial livestock purposes.

1.6 All hookups to the Progressive system shall comply with the City's Back Flow Prevention Ordinance.

1.7 There shall be only one equivalent residential unit ERU for each hookup to the system

except for Farm Labor Housing Facilities which are designed for several residents.

1.8 All members and/or recipients of domestic water delivered through the Progressive system shall be subject to the regulations contained to Title 13 of the Okanogan Municipal Code.

1.9 The City does not guarantee delivery of any water at any specific pressure or fire flow volume in the Progressive system unless the Progressive system is upgraded to standards required of the City system by the City's Municipal Code, the Revised Code of Washington and pertinent regulations of the Washington Administrative Code. Any easements necessary to upgrade the Progressive system will be the responsibility of Progressive.

1.10 Progressive shall install a back flow prevention device acceptable to the City and consistent with City standards and specification at the location of the main valve connecting the City water system to the Progressive water system.

1.11 Progressive will install at least one sampling station at the location where the City's water system is connected to the Progressive system. Material specification for the sampling station shall be in accordance with City requirements and all costs of labor, materials and equipment necessary for installation of the sampling station shall be at the expense of Progressive.

1.12 The City will take water samples monthly from the sampling station as indicated in Paragraph 1.10 above to test for the presence of coliforms as required by the Washington State Department of Health. The water samples will be shipped to an independent laboratory for testing. The City will invoice Progressive and Progressive will pay the City on a monthly basis for all costs to take, ship and test the samples.

1.13 Should the presence of coliforms be detected, repeat samples will be taken and tests made as required by Chapter 246-290 of the Washington Administrative Code. If the source of contamination is determined to be from the Progressive system, Progressive will be responsible for all costs of the contamination as relates to the Department of Health Regulations, including additional testing, within the City system and the Progressive system, and Progressive agrees that it will install City approved back flow devices at Progressive's costs for all individual hookups. If the source of contamination is determined to be caused from the City's system, the City will assume all costs for the contamination as relates to the Department of Health Regulations, including testing.

1.14 Should the Washington State Department of Ecology or Washington State Department of Health increase the testing frequency or add other monitoring requirements, Progressive agrees to pay additional costs for these tests whenever they are imposed upon the City.



## II.

2.1 Progressive agrees that it and its members will hold City harmless from any liabilities of persons or property for any damages to persons or property which may result from the use or operation or maintenance of the system installed by Progressive including but not limited to lack of water or water pressure.

2.2 Progressive will at its own expense maintain in force general comprehensive liability insurance naming the City as additional insured in order to protect the City and its personnel against liability for loss or damages or bodily injury, death, and property damages caused by the activities of Progressive under this agreement. Minimum limits under the policy will be ONE MILLION and NO/100 (\$1,000,000.00) Dollars resulting from any one occurrence. Evidence of said coverage in the form of a valid certificate of insurance, showing the City named as additional insured, will be submitted to the City Clerk within 60 days of final execution of this agreement.

2.3 Progressive agrees that it will reimburse the City in full within 15 days of receiving an invoice showing the amount of water delivered to Progressive through the City's water delivery system as metered by a meter to be installed at the connection of the City water system to Progressive's water system. Wholesale water rates to be charged to Progressive shall be at the beginning rate of \$1.08 for every thousand gallons delivered to Progressive during a preceding month. The parties also agree that the rate per thousand gallons will be reviewed and adjusted annually as are the City's water rates.

The City shall not interfere in any way or require any arrangement pursuant to which Progressive secures reimbursement of the wholesale cost of water delivered to its system from those receiving water through Progressive's delivery system.

2.4 In the event that the Progressive Board of Directors dissolves, or does not pay the invoice by the end of the month in which it is sent, the City's recourse will be to discontinue water service to the Progressive Flat System. This action will be preceded by an attempt to provide telephonic notice to the Progressive Flats Board of Directors 24 hours in advance of the turn off. In event of a delinquency of this account, the standard penalties and turn off, turn on charges specified in the City's Fee Schedule in affect at the time will be imposed prior to resumption of service.

## III.

It is understood and agreed between the parties that in the event that there is insufficient water to serve all the demand on the City's water system, that water rationing or restrictions will be equally applied to Progressive Flats and the City's individual customers.

Progressive Flats agrees to enforce any such rationing or restrictions on their customers as is applied to other City customers.

**IV.**

Progressive agrees to furnish the City Water Department and Public Works Department engineered As-Built plans of Progressive's system, including any upgrades or modifications to Progressive system, within 30 days after any installation or modification to Progressive's system.

**V.**

Though not a requirement of this agreement, it is understood and anticipated by the parties that some property owners of areas served by Progressive's water system may request annexation to the City, and in which event, annexation shall proceed as follows:

1. Annexations, if any, shall occur in a progressive sequence that does not create islands or peninsulas.
2. In the event of such annexation, all City utilities, including water and sewer, shall be upgraded by the property owner/developer in accordance with the City's comprehensive plan for Progressive's service area.

**VI.**

Progressive shall be responsible to inform its members no less than 48 hours in advance of water outages due to planned maintenance or upgrading of Progressive's water system. Progressive shall be responsible for all water taps, permits, and costs of maintenance and construction of its system on County roads or City street rights of way.

**VII.**

This agreement shall be binding upon and inure to the benefit of heirs, successors and assigns of the members of Progressive.

**VIII.**

This agreement shall continue for a period of Twenty (20) years from the date of this agreement. At the end of the initial twenty-year period this agreement may be renewed, amended or terminated by mutual agreement of the Parties.

IN WITNESS WHEREOF, we have hereunto set our hands this 14<sup>th</sup> day of November, 2006.

CITY OF OKANOGAN

PROGRESSIVE FLAT WATER ASSN.

  
\_\_\_\_\_  
Michael Blake, Mayor

  
\_\_\_\_\_  
President

Attested:

  
\_\_\_\_\_  
Ralph Malone, City Clerk

  
\_\_\_\_\_  
Secretary

Approved as to form:

  
\_\_\_\_\_  
Owen M. Gardner, City Attorney

STATE OF WASHINGTON )

:SS

County of Okanogan )

On this 7<sup>th</sup> day of November, 2006, before me, a Notary Public in and for the above-named County and State, personally appeared Michael Blake and Ralph Malone to be known to be the Mayor and City Clerk respectively of the municipality that executed the within and foregoing instrument, and acknowledged the said instrument to be the free and voluntary act and deed of said municipality, for the uses and purposes therein mentioned, and each on oath stated that he was authorized to execute said instrument.

In witness whereas I have hereunto set my hand and affixed by official seal the day and year first above written.

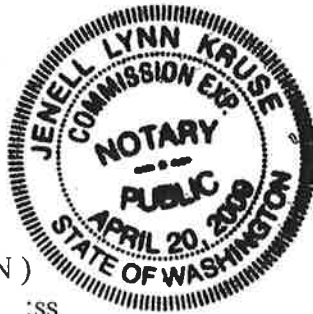

Jenell Lynn Kruse  
Notary Public for the State of Washington,  
residing in Okanogan.  
My Commission Expires 04-20-09.

STATE OF WASHINGTON )

:SS

County of Okanogan )

On this 14<sup>th</sup> day of November, 2006, before me, a Notary Public in and for the above-named County and State, personally appeared John Sherlock and \_\_\_\_\_ to be known to be the President and Secretary respectively of the corporation that executed the within and foregoing instrument, and acknowledged the said instrument to be the free and voluntary act and deed of said corporation, for the uses and purposes therein mentioned, and each on oath stated that he/she was authorized to executed said instrument.

In witness whereas I have hereunto set my hand and affixed by official seal the day and year first above written.

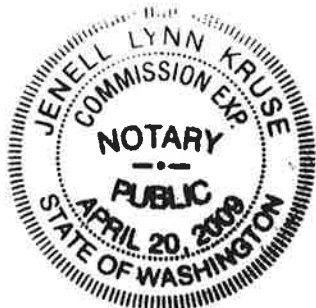

Jenell Lynn Kruse  
Notary Public for the State of Washington,  
residing in Okanogan.  
My Commission Expires April 20, 2009

STATE OF WASHINGTON )

:ss

County of Okanogan )

On this 9<sup>th</sup> day of November, 2006, before me, a Notary Public in and for the above-named County and State, personally appeared Michael Blake and Ralph Malone to be known to be the Mayor and City Clerk respectively of the municipality that executed the within and foregoing instrument, and acknowledged the said instrument to be the free and voluntary act and deed of said municipality, for the uses and purposes therein mentioned, and each on oath stated that he was authorized to execute said instrument.

In witness whereas I have hereunto set my hand and affixed by official seal the day and year first above written.

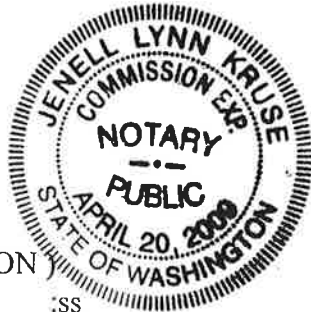

Jenell Lynn Kruse  
Notary Public for the State of Washington,  
residing in Okanogan.  
My Commission Expires 04-20-09.

STATE OF WASHINGTON )

:ss

County of Okanogan )

On this 9<sup>th</sup> day of November, 2006, before me, a Notary Public in and for the above-named County and State, personally appeared B.D. Blank and [redacted] to be known to be the ~~President and Secretary respectively~~ of the corporation that executed the within and foregoing instrument, and acknowledged the said instrument to be the free and voluntary act and deed of said corporation, for the uses and purposes therein mentioned, and each on oath stated that he/she was authorized to executed said instrument.

In witness whereas I have hereunto set my hand and affixed by official seal the day and year first above written.



Jenell Lynn Kruse  
Notary Public for the State of Washington,  
residing in Okanogan.  
My Commission Expires 04-20-09.

**APPENDIX N**  
**RESOLUTION**

## SUBSTITUTE

### RESOLUTION No. 2006-19

#### **A RESOLUTION OF THE CITY COUNCIL OF THE CITY OF OKANOGAN, WASHINGTON, FORMALIZING ITS POLICY ON WATER UTILITY CONNECTIONS IN LOCATIONS OUTSIDE OF THE OKANOGAN CITY LIMITS**

**WHEREAS**, the City of Okanogan has maintained a policy of not providing water service connections to properties outside of the city limits for many years, and this policy is evidenced by repeated references thereto in council minutes over the years; and

**WHEREAS**, it is a prudent policy to reserve the limited water resources of the City of Okanogan for distribution to those areas that are located within the City Limits of the City of Okanogan; and

**WHEREAS**, adoption of a formal policy through Resolution will establish with certainty the conditions under which the City of Okanogan will provide water service.

**NOW, THEREFORE, BE IT RESOLVED by the City Council of the City of Okanogan:**

**Section 1.** No water service connection will be allowed to a property outside of the Okanogan city limits unless one of the following three conditions are met.

A. The City or Applicant can demonstrate that a health emergency exists that warrants extension of city services to said property or properties. In all such cases, the Applicant shall demonstrate that adequate water rights exist to offset any such commitment by the City and shall take all steps necessary to transfer said rights to the City.

OR

B. The Applicant is an instrumentality of the State, Federal or Tribal Government and the service is for a public purpose and the City finds that it is in its best interest to provide the service.

OR

C. Applicant can demonstrate through physical evidence that a city water service existed at the proposed service site in the past,

OR

Applicant can provide acceptable documentation that a city water service existed at the service site by production of city billing



---

records, recorded easements or other definitive evidence to demonstrate that the property was served by city water in the past,

OR

Applicant can provide acceptable documentation of past agreements reached between the City and the property owners providing for extension of rural water to said property or properties,

AND

Applicant is unable to annex the property into the City.

**Section 2.** The following requirements must be met before service will be restored or extended to any property outside the boundaries of the City.

- A. The necessary water line must be installed or repaired to City specifications at the expense of the applicant.
- B. Maintenance of the water line will be the sole responsibility of the applicant and any subsequent property owners.
- C. An approved backflow prevention device must be installed if required by the Public Works Superintendent.
- D. Restored or extended water service cannot exceed the original use type established in Section No. 1 above. Specifically no subdivisions, additional services or expanded uses such as motels, apartments or businesses will be allowed, unless specifically authorized under water rights transferred to the City.
- E. All applicable fees for extension / restoration of water service will be paid by the property owner(s).
- F. Application for rural water connection is approved by the Okanogan City Council
- G. Rural water service rates will apply to all such services, except in such cases where unique circumstances and/or agreements stipulate otherwise.

**Section 3.** The restrictions imposed in Section 2 above will continue until such time as the property is formally and officially annexed into the City of Okanogan in accordance with State of Washington Statute. Upon annexation into the City of Okanogan, the properties will be treated in the same manner as all other properties with a water service connection within the City limits.

**PASSED BY THE CITY COUNCIL AND APPROVED BY THE MAYOR OF THE CITY OF OKANOGAN** this 19<sup>th</sup> day of December, 2006.

---

**APPROVED:**



---

**Michael Blake, Mayor**

**ATTEST:**

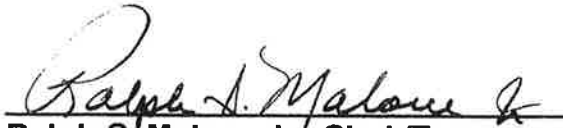

---

**Ralph S. Malone Jr., Clerk/Treasurer**

**APPENDIX O**  
**COUNCIL MEETING DOCUMENTATION**

# CITY OF OKANOGAN COUNCIL AGENDA

Special Meeting

Thursday June 16, 2016

2:00 pm in Council Chambers

1. Call to Order and Pledge of Allegiance

2. Approval of Agenda

3. New Business

Review of the City's six and twenty year capital improvement schedule from the draft Comprehensive Water System Plan.

Review of the City's completed rate study

4. Public Comments

5. Councilmembers Comments

6. Mayor's Comments

7. Adjournment

**CITY OF OKANOGAN  
SPECIAL COUNCIL MEETING MINUTES  
June 16, 2016**

**CALL TO ORDER**

The Special Meeting of the Okanogan City Council was called to order by Mayor Culp at 2:00 p.m. and all stood for the Pledge of Allegiance.

The following were:

Present: Mayor Culp      Councilmembers: Patricia Stanton, Lisa Bauer, Kristina McIntosh, Denise Varner, and Janet Wilson.

Also Present: Deputy Clerk Treasurer Susan Skirko-Stewart, Public Works Director Shawn Davisson, and Water Manager Loren Howell.

**APPROVAL OF AGENDA**

Mayor Culp asked if there were any alterations to the Agenda or Consent Agenda. Varner moved, seconded by Wilson to approve the Agenda as presented. Mayor Culp asked if there were any objections to the motion. Seeing no objection raised, the motion passed without objection.

**NEW BUSINESS**

Review of the City's six and twenty year capital improvement schedule from the draft Comprehensive Water System Plan

There was a lengthy discussion regarding the Gray & Osborne proposed rate restructure table.

Varner communicated some additional options and there was discussion amongst the other Councilmembers and staff with regards to the proposals she presented.

Review of the City's completed rate study

The Councilmembers and staff present reviewed the draft of the rate study and discussion ensued.

Also discussed, was preparing for the Public Outreach Meeting at the American Legion Hall on Tuesday, July 12, 2016.

**PUBLIC COMMENT**

There was no public present at the meeting.

**COUNCILMEMBER'S COMMENT**

There were no Councilmember Comments.

**MAYOR'S COMMENT**

The Mayor had no comments.

**ADJOURNMENT**

There being no further business before the Council, the Meeting was adjourned at 4:05 p.m.

Minutes taken and prepared by Deputy Clerk Treasurer Susan Skirko-Stewart

**APPROVED:**



---

**Jon Culp, Mayor**

**ATTEST:**



---

**Susan Skirko-Stewart, Deputy Clerk Treasurer**

**CITY OF OKANOGAN  
COUNCIL MINUTES  
July 12, 2016**

**CALL TO ORDER**

The Rescheduled Meeting of the Okanogan City Council was called to order by Alternative Mayor Pro Tem Bauer at Okanogan Legion Hall at 7:00 p.m. and all stood for the Pledge of Allegiance.

The following were:

Present: Alternate Mayor Pro Tem Lisa Bauer      Councilmembers: Denise Varner, Patricia Stanton, and Janet Wilson.

Also Present: Clerk Treasurer Craig Attwood, Deputy Clerk-Treasurer Susan Skirko Stewart, Public Works Director Shawn Davisson, Sergeant Tony Hawley of the Okanogan County Sheriff's Department, and Dave Ellis of Gray & Osborne, Inc.

Alternate Mayor Pro tem Bauer announced that Councilmember Kristina McIntosh contacted her and will not be in attendance due to illness.

Stanton moved, seconded by Varner to excuse Councilmember McIntosh due to illness. The motion passed without objection.

Excused: Councilmember Kristina McIntosh

**APPROVAL OF AGENDA AND CONSENT AGENDA**

Alternative Mayor Pro Tem Bauer asked if there were any alterations to the Agenda or Consent Agenda. Stanton moved, seconded by Varner to approve the Agenda and Consent Agenda as presented. Alternate Mayor Pro tem Bauer asked if there were any objections to the motion. Seeing no objection raised, the motion passed without objection.

**EXCUSE COUNCILMEMBERS**

Councilmember Wayne Turner was excused with passage of the Agenda and Consent Agenda.

**APPROVAL OF MINUTES**

The Minutes of the Regularly Scheduled Council Meeting of June 28, 2016 were approved with passage of the Consent Agenda.



### **APPROVAL OF VOUCHERS**

Claims Vouchers numbered 42761 – 42812 dated July 12, 2016 in the amount of \$105,011.33, Payroll Checks numbered 42652 through 42676 and 42713 through 42760 in the amount of \$98,180.99, a Debit Card Transaction dated June 30, 2016 in the amount of \$402.28, and a Debit Card Transaction dated July 5, 2016, in the amount of \$11,516.09 were approved with the Consent Agenda.

### **PUBLIC COMMENT**

Alternate Mayor Pro tem Bauer opened the floor for Public Comment. Seeing none raised, Public Comment was closed.

### **DEPARTMENT HEAD REPORTS**

Director of Public Works Davisson submitted a written report.

Clerk's Office submitted a written report.

Sheriff's Department submitted a written report. In addition, Sergeant Hawley reviewed the month to date and year to date statistics.

Building Official submitted a written report, but was not present at the meeting.

### **COMMITTEE REPORTS**

There were no Committee Reports on the Agenda.

### **UNFINISHED BUSINESS**

There was no unfinished business on the Agenda.

### **NEW BUSINESS**

*Eric Sheldon Lind Sr.; Council Position No. 3*

Alternate Mayor Pro tem Bauer introduced Mr. Lind and invited him to give a brief overview about himself and why he would like to be on Okanogan City Council.

Mr. Lind stood, introduced himself and gave a brief presentation.

Varner moved, seconded by Stanton to appoint Mr. Lind to Council Position No. 3.

Vote on the motion.

Ayes: Wilson, Stanton, Varner, and Bauer

Noes: None

Motion carried: 4 Ayes: 0 Noes

Clerk Treasurer Attwood administered the Oath of Office to Mr. Lind and Mr. Lind took his seat with the other Councilmembers.

WWTF Headworks Improvements Contract Award KRCI, LLC \$504,861.20

Director of Public Works Davisson introduced the WWTF Headworks Improvement Contract Award. In addition, he provided a brief overview of the project.

Wilson moved, seconded by Stanton that the City of Okanogan award the WWTF Headworks Improvements to KRCI, LLC in the amount of \$504,861.20.

There was a brief discussion.

Ayes: Wilson, Stanton, Varner, Bauer, and Lind

Noes: None

Motion carried: 5 Ayes: 0 Noes

Annexation Notice of Intent - Pfeiffer

Clerk Treasurer Attwood introduced the Pfeiffer Annexation Notice of Intent and explained the background regarding the request.

Varner moved, seconded by Wilson to refer the inquires to the Planning Commission for a recommendation. This recommendation is to be returned to the Council no later than July 15<sup>th</sup>. The Council will respond to Ms. Pfeiffer's inquiries during our regular July 19<sup>th</sup> meeting.

There was a brief discussion.

Ayes: Stanton, Varner, Bauer, Lind, and Wilson

Noes: None

Motion carried: 5 Ayes: 0 Noes

City of Okanogan & Okanogan County to Perform Chip Seal

Director of Public Works Davisson introduced the City of Okanogan & Okanogan County chip seal agreement.

Wilson moved, seconded by Stanton to approve Mayor Culp sign the agreement with Okanogan County to perform chip sealing on City owned portions of the Okanogan Airport Road & Okanogan Landfill Road.

There was a brief discussion.

Ayes: Varner, Bauer, Lind, Wilson, and Stanton

Noes: None

Motion Passed: 5 Ayes: 0 Noes

**Workshop**

Okanogan Water Service Area

Dave Ellis of Gray & Osborne, Inc. presented a power point presentation outlining the Okanogan Water Service Area.

City of Okanogan Water System Capital Improvement Plan

Dave Ellis of Gray & Osborne, Inc. presented a power point presentation outlining the Okanogan Water System Capital Improvement Plan.

City of Okanogan Water Rate Options

Dave Ellis of Gray & Osborne, Inc. presented a power point presentation outlining a variety of possible rate structures for the City of Okanogan to consider for future Fee Schedules.

**PUBLIC COMMENT**

Alternate Mayor Pro tem Bauer opened the floor for Public Comment. Seeing none raised, Public Comment was closed.

### **COUNCILMEMBER'S COMMENT**

Varner announced she will be absent at the July 19, 2016 Council Meeting.

Stanton commented that she had recently had a conversation with Omak Officer Bjur at Safeway regarding crime. In addition, Officer Bjur suggested that the new Omak Chief of Police would like to have a discussion with the City of Okanogan about contracting with the City of Omak for law enforcement services or possibly to fill in with officers or reserve officers from Omak where there are gaps in coverage times through the Sheriff's Office.

### **MAYOR'S REPORT**

There was no Mayor's Report.

### **ADJOURNMENT**

There being no further business before the Council, the Meeting was adjourned at 8:55p.m.

Minutes taken and prepared by Deputy Clerk Treasurer, Susan Skirko-Stewart

### **APPROVED:**



---

**Lisa Bauer, Alternate Mayor Pro tem**

### **ATTEST:**

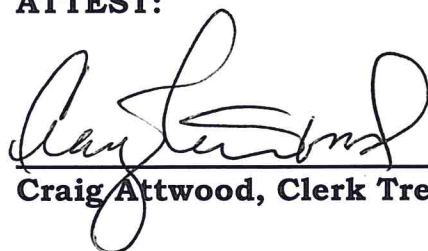

---

**Craig Attwood, Clerk Treasurer**

**APPENDIX P**

**NOTICE TO ADJACENT UTILITY PROVIDERS**



March 24, 2016

Mr. Douglas Hale  
Progressive Flats Water Association  
4 Norway Pines Drive  
Tonasket, Washington 98855

SUBJECT: OKANOGAN WATER SYSTEM PLAN  
CITY OF OKANOGAN, OKANOGAN COUNTY, WASHINGTON  
G&O #15012

Dear Mr. Hale:

The purpose of this letter is to inform you that the City of Okanogan has available for the Association's review a draft of their Water System Plan. If you would like a copy of the Plan please contact David Ellis, P.E., Gray & Osborne, Inc., at (509) 453-4833 or by email at [dellis@g-o.com](mailto:dellis@g-o.com).

Sincerely,

GRAY & OSBORNE, INC.

David G. Ellis, P.E.

DGE/tlf

cc: Mr. Shawn Davisson, Public Works Director, City of Okanogan





**Gray & Osborne, Inc.**

CONSULTING ENGINEERS

March 24, 2016

Mr. Corey Wilder  
City of Omak Water Department  
P.O. Box 72  
Omak, Washington 98841

SUBJECT: OKANOGAN WATER SYSTEM PLAN  
CITY OF OKANOGAN, OKANOGAN COUNTY, WASHINGTON  
G&O #15012

Dear Mr. Wilder:

The purpose of this letter is to inform you that the City of Okanogan has available for the City's review a draft of their Water System Plan. If you would like a copy of the Plan please contact David Ellis, P.E., Gray & Osborne, Inc., at (509) 453-4833 or by email at [dellis@g-o.com](mailto:dellis@g-o.com).

Sincerely,

GRAY & OSBORNE, INC.

David G. Ellis, P.E.

DGE/tlf

cc: Mr. Shawn Davisson, Public Works Director, City of Okanogan





**Gray & Osborne, Inc.**

CONSULTING ENGINEERS

March 24, 2016

Mr. Maurice Goodall  
Okanogan County Fair Water System  
P.O. Box 467  
Okanogan, Washington 98840

SUBJECT: OKANOGAN WATER SYSTEM PLAN  
CITY OF OKANOGAN, OKANOGAN COUNTY, WASHINGTON  
G&O #15012

Dear Mr. Goodall:

The purpose of this letter is to inform you that the City of Okanogan has available for your review a draft of their Water System Plan. If you would like a copy of the Plan please contact David Ellis, P.E., Gray & Osborne, Inc., at (509) 453-4833 or by email at [dellis@g-o.com](mailto:dellis@g-o.com).

Sincerely,

GRAY & OSBORNE, INC.

David G. Ellis, P.E.

DGE/tlf

cc: Mr. Shawn Davisson, Public Works Director, City of Okanogan



March 24, 2016

Father Luta Nsubuga  
Our Lady of Valley Catholic Church Water System  
2511 Elmway  
Okanogan, Washington 98840

SUBJECT: OKANOGAN WATER SYSTEM PLAN  
CITY OF OKANOGAN, OKANOGAN COUNTY, WASHINGTON  
G&O #15012

Dear Father Nsubuga:

The purpose of this letter is to inform you that the City of Okanogan has available for your review a draft of their Water System Plan. If you would like a copy of the Plan please contact David Ellis, P.E., Gray & Osborne, Inc., at (509) 453-4833 or by email at dellis@g-o.com.

Sincerely,

GRAY & OSBORNE, INC.

David G. Ellis, P.E.

DGE/tlf

cc: Mr. Shawn Davisson, Public Works Director, City of Okanogan



March 31, 2016

Mr. Douglas Hale  
Progressive Flats Water Association  
4 Norway Pines Drive  
Tonasket, Washington 98855

SUBJECT: OKANOGAN WATER SYSTEM PLAN  
CITY OF OKANOGAN, OKANOGAN COUNTY, WASHINGTON  
G&O #15012

Dear Mr. Hale:

As per your request, please find the attached copy of the City of Okanogan's draft Water System Plan.

Let me know if you have any questions or require additional information.

Sincerely,

GRAY & OSBORNE, INC.

David G. Ellis, P.E.

DGE/kd  
Encl.

cc: Mr. Shawn Davisson, Public Works Director, City of Okanogan, w/o encl.